

Markscheme

May 2025

**Mathematics: applications and
interpretation**

Higher level

Paper 1

© International Baccalaureate Organization 2025

All rights reserved. No part of this product may be reproduced in any form or by any electronic or mechanical means, including information storage and retrieval systems, without the prior written permission from the IB. Additionally, the license tied with this product prohibits use of any selected files or extracts from this product. Use by third parties, including but not limited to publishers, private teachers, tutoring or study services, preparatory schools, vendors operating curriculum mapping services or teacher resource digital platforms and app developers, whether fee-covered or not, is prohibited and is a criminal offense.

More information on how to request written permission in the form of a license can be obtained from <https://ibo.org/become-an-ib-school/ib-publishing/licensing/applying-for-a-license/>.

© Organisation du Baccalauréat International 2025

Tous droits réservés. Aucune partie de ce produit ne peut être reproduite sous quelque forme ni par quelque moyen que ce soit, électronique ou mécanique, y compris des systèmes de stockage et de récupération d'informations, sans l'autorisation écrite préalable de l'IB. De plus, la licence associée à ce produit interdit toute utilisation de tout fichier ou extrait sélectionné dans ce produit. L'utilisation par des tiers, y compris, sans toutefois s'y limiter, des éditeurs, des professeurs particuliers, des services de tutorat ou d'aide aux études, des établissements de préparation à l'enseignement supérieur, des fournisseurs de services de planification des programmes d'études, des gestionnaires de plateformes pédagogiques en ligne, et des développeurs d'applications, moyennant paiement ou non, est interdite et constitue une infraction pénale.

Pour plus d'informations sur la procédure à suivre pour obtenir une autorisation écrite sous la forme d'une licence, rendez-vous à l'adresse <https://ibo.org/become-an-ib-school/ib-publishing/licensing/applying-for-a-license/>.

© Organización del Bachillerato Internacional, 2025

Todos los derechos reservados. No se podrá reproducir ninguna parte de este producto de ninguna forma ni por ningún medio electrónico o mecánico, incluidos los sistemas de almacenamiento y recuperación de información, sin la previa autorización por escrito del IB. Además, la licencia vinculada a este producto prohíbe el uso de todo archivo o fragmento seleccionado de este producto. El uso por parte de terceros —lo que incluye, a título enunciativo, editoriales, profesores particulares, servicios de apoyo académico o ayuda para el estudio, colegios preparatorios, desarrolladores de aplicaciones y entidades que presten servicios de planificación curricular u ofrezcan recursos para docentes mediante plataformas digitales—, ya sea incluido en tasas o no, está prohibido y constituye un delito.

En este enlace encontrará más información sobre cómo solicitar una autorización por escrito en forma de licencia: <https://ibo.org/become-an-ib-school/ib-publishing/licensing/applying-for-a-license/>.

Instructions to Examiners

Abbreviations

- M** Marks awarded for attempting to use a correct **Method**.
- A** Marks awarded for an **Answer** or for **Accuracy**; often dependent on preceding **M** marks.
- R** Marks awarded for clear **Reasoning**.
- AG** Answer given in the question and so no marks are awarded.
- FT** Follow through. The practice of awarding marks, despite candidate errors in previous parts, for their correct methods/answers using incorrect results.

Using the markscheme

1 General

Award marks using the annotations as noted in the markscheme eg **M1**, **A2**.

2 Method and Answer/Accuracy marks

- Do **not** automatically award full marks for a correct answer; all working **must** be checked, and marks awarded according to the markscheme.
- It is generally not possible to award **M0** followed by **A1**, as **A** mark(s) depend on the preceding **M** mark(s), if any.
- Where **M** and **A** marks are noted on the same line, e.g. **M1A1**, this usually means **M1** for an **attempt** to use an appropriate method (e.g. substitution into a formula) and **A1** for using the **correct** values.
- Where there are two or more **A** marks on the same line, they may be awarded independently; so if the first value is incorrect, but the next two are correct, award **A0A1A1**.
- Where the markscheme specifies **A3**, **M2** etc., do **not** split the marks, unless there is a note.
- The response to a “show that” question does not need to restate the **AG** line, unless a **Note** makes this explicit in the markscheme.
- Once a correct answer to a question or part question is seen, ignore further working even if this working is incorrect and/or suggests a misunderstanding of the question. This will encourage a uniform approach to marking, with less examiner discretion. Although some candidates may be advantaged for that specific question item, it is likely that these candidates will lose marks elsewhere too.
- An exception to the previous rule is when an incorrect answer from further working is used **in a subsequent part**. For example, when a correct exact value is followed by an incorrect decimal approximation in the first part and this approximation is then used in the second part. In this situation, award **FT** marks as appropriate but do not award the final **A1** in the first part.

Examples:

	Correct answer seen	Further working seen	Any FT issues?	Action
1.	$8\sqrt{2}$	5.65685... (incorrect decimal value)	No. Last part in question.	Award A1 for the final mark (condone the incorrect further working)
2.	$\frac{35}{72}$	0.468111... (incorrect decimal value)	Yes. Value is used in subsequent parts.	Award A0 for the final mark (and full FT is available in subsequent parts)

3 Implied marks

Implied marks appear in **brackets e.g. (M1)**, and can only be awarded if **correct** work is seen or implied by subsequent working/answer.

4 Follow through marks (only applied after an error is made)

Follow through (**FT**) marks are awarded where an incorrect answer from one **part** of a question is used correctly in **subsequent** part(s) (e.g. incorrect value from part (a) used in part (d) or incorrect value from part (c)(i) used in part (c)(ii)). Usually, to award **FT** marks, **there must be working present** and not just a final answer based on an incorrect answer to a previous part. However, if all the marks awarded in a subsequent part are for the answer or are implied, then **FT** marks should be awarded for *their* correct answer, even when working is not present.

For example: following an incorrect answer to part (a) that is used in subsequent parts, where the markscheme for the subsequent part is **(M1)A1**, it is possible to award full marks for *their* correct answer, **without working being seen**. For longer questions where all but the answer marks are implied this rule applies but may be overwritten by a **Note** in the Markscheme.

- Within a question part, once an **error** is made, no further **A** marks can be awarded for work which uses the error, but **M** marks may be awarded if appropriate.
- If the question becomes much simpler because of an error then use discretion to award fewer **FT** marks, by reflecting on what each mark is for and how that maps to the simplified version.
- If the error leads to an inappropriate value (e.g. probability greater than 1, $\sin \theta = 1.5$, non-integer value where integer required), do not award the mark(s) for the final answer(s).
- The markscheme may use the word “their” in a description, to indicate that candidates may be using an incorrect value.
- If the candidate’s answer to the initial question clearly contradicts information given in the question, it is not appropriate to award any **FT** marks in the subsequent parts. This includes when candidates fail to complete a “show that” question correctly, and then in subsequent parts use their incorrect answer rather than the given value.
- Exceptions to these **FT** rules will be explicitly noted on the markscheme.
- If a candidate makes an error in one part but gets the correct answer(s) to subsequent part(s), award marks as appropriate, unless the command term was “Hence”.

5 Mis-read

If a candidate incorrectly copies values or information from the question, this is a mis-read (**MR**). A candidate should be penalized only once for a particular misread. Use the **MR** stamp to indicate that this has been a misread and do not award the first mark, even if this is an **M** mark, but award all others as appropriate.

- If the question becomes much simpler because of the **MR**, then use discretion to award fewer marks.
- If the **MR** leads to an inappropriate value (e.g. probability greater than 1, $\sin \theta = 1.5$, non-integer value where integer required), do not award the mark(s) for the final answer(s).
- Miscopying of candidates' own work does **not** constitute a misread, it is an error.
- If a candidate uses a correct answer, to a "show that" question, to a higher degree of accuracy than given in the question, this is NOT a misread and full marks may be scored in the subsequent part.
- **MR** can only be applied when work is seen. For calculator questions with no working and incorrect answers, examiners should **not** infer that values were read incorrectly.

6 Alternative methods

Candidates will sometimes use methods other than those in the markscheme. Unless the question specifies a method, other correct methods should be marked in line with the markscheme. If the command term is 'Hence' and not 'Hence or otherwise' then alternative methods are not permitted unless covered by a note in the mark scheme.

- Alternative methods for complete questions are indicated by **METHOD 1**, **METHOD 2**, etc.
- Alternative solutions for parts of questions are indicated by **EITHER . . . OR**.

7 Alternative forms

Unless the question specifies otherwise, **accept** equivalent forms.

- As this is an international examination, accept all alternative forms of **notation** for example 1.9 and 1,9 or 1000 and 1,000 and 1.000.
- Do not accept final answers written using calculator notation. However, **M** marks and intermediate **A** marks can be scored, when presented using calculator notation, provided the evidence clearly reflects the demand of the mark.
- In the markscheme, equivalent **numerical** and **algebraic** forms will generally be written in brackets immediately following the answer.
- In the markscheme, some **equivalent** answers will generally appear in brackets. Not all equivalent notations/answers/methods will be presented in the markscheme and examiners are asked to apply appropriate discretion to judge if the candidate work is equivalent.

8 Format and accuracy of answers

If the level of accuracy is specified in the question, a mark will be linked to giving the answer to the required accuracy. If the level of accuracy is not stated in the question, the general rule applies to final answers: *unless otherwise stated in the question all numerical answers must be given exactly or correct to three significant figures.*

Where values are used in subsequent parts, the markscheme will generally use the exact value, however candidates may also use the correct answer to 3 sf in subsequent parts. The markscheme will often explicitly include the subsequent values that come “*from the use of 3 sf values*”.

Simplification of final answers: Candidates are advised to give final answers using good mathematical form. In general, for an **A** mark to be awarded, arithmetic should be completed, and any

values that lead to integers should be simplified; for example, $\sqrt{\frac{25}{4}}$ should be written as $\frac{5}{2}$. An

exception to this is simplifying fractions, where lowest form is not required (although the numerator and the denominator must be integers); for example, $\frac{10}{4}$ may be left in this form or written as $\frac{5}{2}$.

However, $\frac{10}{5}$ should be written as 2, as it simplifies to an integer.

Algebraic expressions should be simplified by completing any operations such as addition and multiplication, e.g. $4e^{2x} \times e^{3x}$ should be simplified to $4e^{5x}$, and $4e^{2x} \times e^{3x} - e^{4x} \times e^x$ should be simplified to $3e^{5x}$. Unless specified in the question, expressions do not need to be factorized, nor do factorized expressions need to be expanded, so $x(x+1)$ and $x^2 + x$ are both acceptable.

Please note: intermediate **A** marks do NOT need to be simplified.

9 Calculators

A GDC is required for this paper, but if you see work that suggests a candidate has used any calculator not approved for IB DP examinations (eg CAS enabled devices), please follow the procedures for malpractice.

10 Presentation of candidate work

Crossed out work: If a candidate has drawn a line through work on their examination script, or in some other way crossed out their work, do not award any marks for that work unless an explicit note from the candidate indicates that they would like the work to be marked.

More than one solution: Where a candidate offers two or more different answers to the same question, an examiner should only mark the first response unless the candidate indicates otherwise. If the layout of the responses makes it difficult to judge, examiners should apply appropriate discretion to judge which is “first”.

1. (a) attempt to calculate area of a circle using 4 or 2.8 **M1**

recognition of multiplication by $\frac{1}{5}$ or $\frac{72}{360}$ **M1**

$$A = \frac{1}{5}(\pi(4)^2 - \pi(2.8)^2)$$

5.13 (m²) (5.12707... (m²), $\frac{204\pi}{125}$ (m²), 1.632π (m²)) **A1**

5.12707... < 6 **OR** Maureen has enough **AG**

Note: Do not award the final **A1** for the area unless a comparison to 6 is shown **OR** a statement of having enough is seen.

[3 marks]

(b) (C =) $2\pi(4)$ (25.1327...) **(A1)**

recognition to multiply by $\frac{3}{5}$ or $\frac{216}{360}$ **(M1)**

$$\frac{3}{5} \times 2\pi(4) + 2 \times 4$$

23.1 (m) (23.0796...(m), $\frac{24\pi}{5} + 8$) **A1**

[3 marks]

[Total: 6 marks]

2. (a) $d = 5.75 \left(d = \frac{23}{4} \right)$ A1A1

Note: Award **A1** for 5.75 seen, **A1** for completely correct equation.

[2 marks]

- (b) attempt to substitute into the axis of symmetry formula using *their* 5.75 **OR** attempt to substitute the coordinates (3, 5.1) or (8.5, 5.1) into the function (M1)

$$5.75 = \frac{-b}{2 \times (-0.2)} \quad \text{OR} \quad 5.1 = -0.2(3)^2 + 3b \quad \text{OR} \quad 5.1 = -0.2(8.5)^2 + 8.5b$$

$(b =) 2.3$

A1
[2 marks]

- (c) indication of finding zero or attempt to use symmetry (M1)

$h(d) = 0$ **OR** $0 = -0.2d^2 + 2.3d$ **OR** 2×5.75 **OR** $3 - 0 = d - 8.5$ **OR**
resketch of graph with zero indicated

$(d =) 11.5 \text{ (m)}$

A1

Note: Award **A0** for a FT answer that is less than 8.5 (contradicts the given information).

[2 marks]

- (d) **EITHER**
the dolphin is below the surface of the water / the dolphin is underwater / the dolphin is in the water R1

OR

the value of h cannot be negative since the definition of the model only applies to the jump

R1
[1 mark]

[Total: 7 marks]

3. (a) (i) $N = 72$
 $I\% = 7.15$
 $PV = \pm 42695$
 $FV = 0$
 $P/Y = 12$
 $C/Y = 12$ **(M1)(A1)**

Note: Award **(M1)** for attempt to use finance app in GDC and **(A1)** for the first five entries correct.

$(PMT \Rightarrow) 730.99$ (USD) **A1**

Note: Do not award final **A1** if answer is not given to 2 d.p. or if given as a negative value.

- (ii) attempt to find 80% of 42 695 **(M1)**

$N = 72$
 $I\% = 6.40$
 $PV = \pm 34156$
 $FV = 0$
 $P/Y = 12$
 $C/Y = 12$ **(A1)**

$(PMT \Rightarrow) 572.54$ (USD) **A1**

Note: Do not award final **A1** if answer is not given to 2 d.p. or if given as a negative value.

[6 marks]

- (b) (i) does not have (enough) money for initial payment / does not want to make initial payment **R1**

- (ii) lower monthly payments / will pay less over the life of the loan / less interest will be paid over life of loan **R1**

[2 marks]

[Total 8 marks]

4. (a) $15p$ A1

[1 mark]

(b) $(p-5)$ or $(n-15)$ seen A1

adding a cost expression (multiplying a p and an n) to their $15p$ (M1)

$C(n) = 15p + (p-5)(n-15)$ OR $C(n) = np - 5n + 75$ (or equivalent) A1
[3 marks]

(c) (i) $(25.73 \times 100 =) 2573$ (EUR) A1

Note: Answer must be exact.

(ii) correctly substituting *their* total cost and $n = 100$ into *their* cost function (A1)
 $2573 = 15p + (p-5)(100-15)$

$(p =) 29.98$ (EUR) A1

Note: Answer must be written to 2 dp.

[3 marks]

[Total: 7 marks]

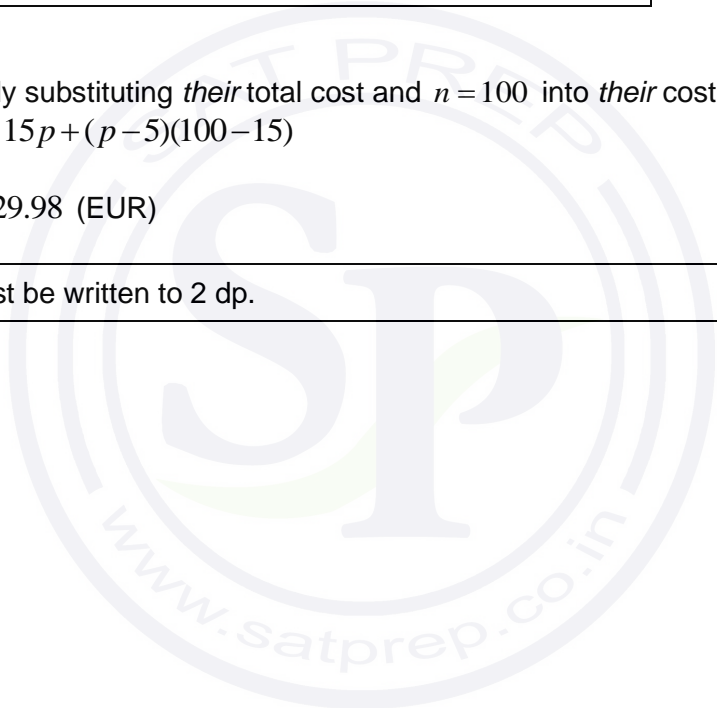

5. (a) (i) 170° (A1)

attempt to substitute into the cosine rule formula (M1)

$$(DC^2) = 2^2 + 13^2 - 2(2)(13) \cos(170^\circ) \quad (A1)$$

$$(DC =) 15.0 \text{ (14.9736...)} \text{ (km)} \quad A1$$

Note: Do not accept a 2sf answer of 15. Award **MOA0A0** for a 2sf answer of 15 with no working shown OR $2+13=15$.

(ii) correct substitution into sine rule or cosine rule (A1)

$$\frac{\sin \hat{BDC}}{13} = \frac{\sin 170^\circ}{14.9736...} \quad \text{OR} \quad \cos(\hat{BDC}) = \frac{14.9736...^2 + 2^2 - 13^2}{2 \times 14.9736... \times 2}$$

$$(\hat{BDC} =) 8.67^\circ \text{ (8.67097...}^\circ) \quad (A1)$$

$$\text{(bearing =) } 098.7^\circ \text{ (098.6709...}^\circ) \quad A1$$

[7 marks]

(b) (distance between points D and E =) 13 (km) A1

points B, C, D, and E make a parallelogram OR DB and EC are parallel and equal in length R1

Note: It is possible to award **A1R0** for this question part.

[2 marks]
[Total 9 marks]

6. (a) (i) $f(x) = 0.7x$ **OR** $f(x) = x - 0.3x$ **A1**
- (ii) $g(x) = x - 150$ **A1**
- [2 marks]**
- (b) attempt to discuss the order in which the reduction/discount are applied **(M1)**
- $(f \circ g)(x)$ describes when the 150 CAD reduction is applied before the 30% discount. **A1**
- [2 marks]**
- (c) **EITHER**
- evidence of solving $(f \circ g)(x)$ and $(g \circ f)(x)$ for a price at 450 CAD **R1**
- OR**
- $(f \circ g)(x) = 0.7x - 105$ and $(g \circ f)(x) = 0.7x - 150$ seen **R1**
- OR**
- stating that it is better for 30% to be deducted from a higher price **R1**
- OR**
- the numbers 165, 210 are seen **R1**
- THEN**
- $(g \circ f)(x)$ is better for the customer **A1**

Note: Do not award **R0A1**.

[2 marks]
[Total 6 marks]

7. (a) (i) correct general shape A1
 curve begins at (0, 1.8) and does not extend beyond $t = 6$ A1

Note: Do not award the second **A1** if the first **A1** is not awarded.

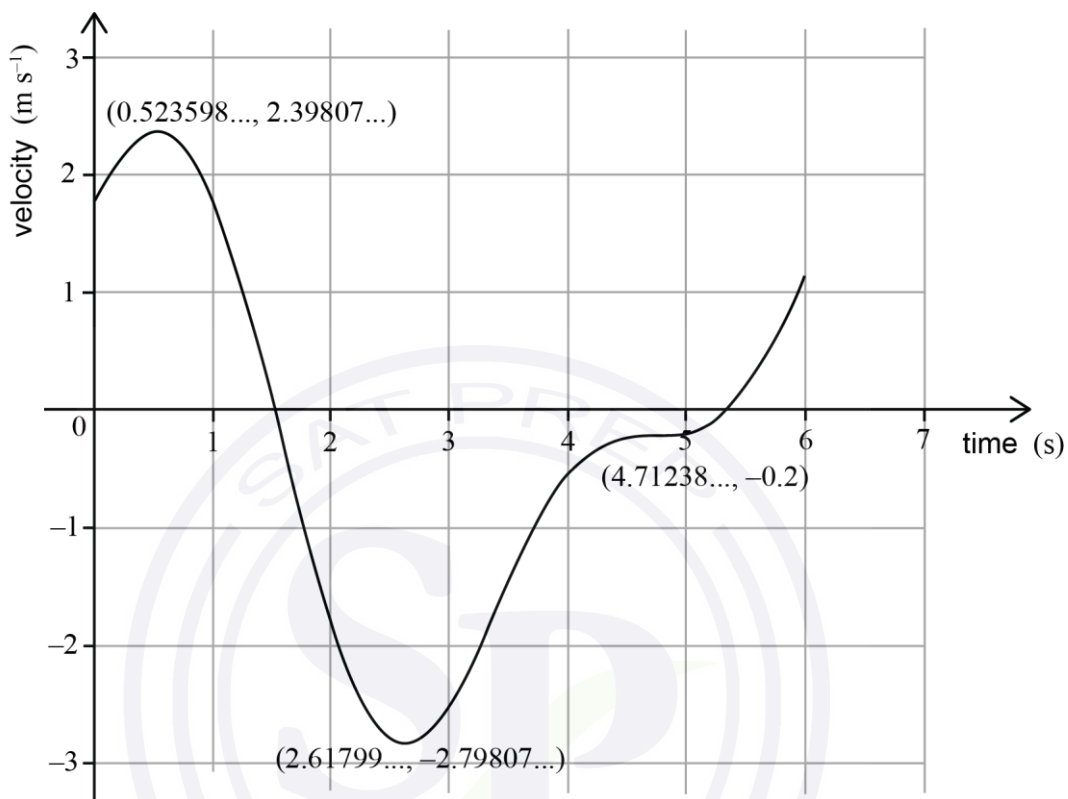

- (ii) (0.524, 2.40) A1
 (2.62, -2.80) A1
 (4.71, -0.2) A1

Note: Award **A1** for each correct coordinate. Award marks even if the labels are not shown on the graph near the points.

[5 marks]

(b) (i) **EITHER**

$$\int_0^6 |2 \cos t + \sin 2t - 0.2| dt$$

A1A1

Note: Award **A1** for correct boundaries and use of dt and **A1** for completely correct expression.

OR

$$\left| \int_0^{1.52074..} (2 \cos t + \sin 2t - 0.2) dt \right| + \left| \int_{1.52074..}^{5.31535..} (2 \cos t + \sin 2t - 0.2) dt \right| + \left| \int_{5.31535..}^6 (2 \cos t + \sin 2t - 0.2) dt \right|$$

A1A1

Note: Award **A1** for 1.52074... and 5.31535... as boundaries and **A1** for completely correct expression.
Allow + - + instead of modulus signs

(ii) 7.76 (7.76487...) (m)

A1

[3 marks]

[Total 8 marks]



8. (a) $f(x) = 0$ seen **OR** sketch of the graph with all three x -intercepts marked **OR** evidence of using sum or product of roots (M1)

($a =$) 3 A1
[2 marks]

(b) evidence of using an integral to find the area (M1)

$$\int f(x), \int_1^3, \text{ etc.}$$

(area =) 4 A1
[2 marks]

(c) attempt to equate two integrals (M1)

$$\int_1^b f(x) dx = \int_1^b g(x) dx$$

evidence of using their GDC to solve the equation **OR** attempt to expand both sides of the equation into expressions in terms of b (M1)

($b =$) 2.57 (2.56949...) A1
[3 marks]

[Total 7 marks]

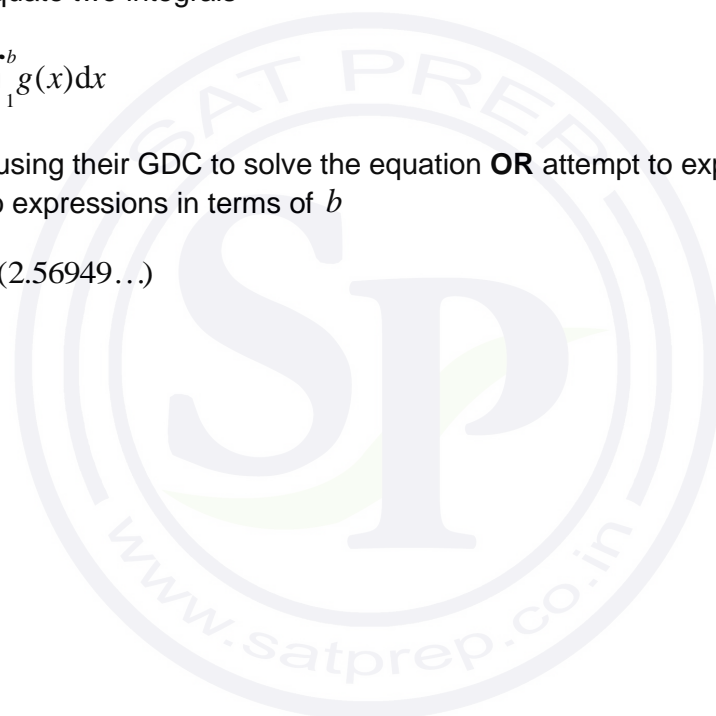

9. (a) Evidence of use of normal cdf with 45 **OR** sketch of bell curve with area above 45 labelled. (M1)

0.0338556... (A1)

recognition of binomial distribution with probability of their 0.0338556... (M1)

$X \sim B(180, 0.0338556\dots)$

$P(X \geq 10)$ **OR** $1 - P(X \leq 9)$

0.0869 (0.0869379...) **A1**
[4 marks]

(b) defining event as being late and lateness marked correctly
 $0.0338556\dots \times (1 - 0.35) = 0.0220061\dots$ (A1)

Y is the number of occasions of being marked late

$Y \sim B(180, 0.0220061)$ **AND** $P(Y \geq 4)$ **OR** $P(Y > 3)$ **OR** $1 - P(Y \leq 3)$ (M1)

0.561 (0.561005...) **A1**
[3 marks]

[Total 7 marks]

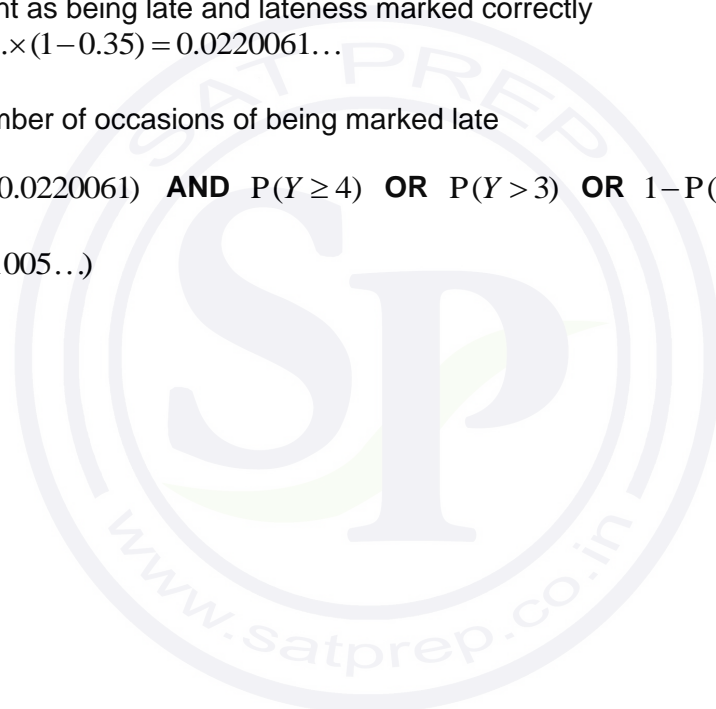

10. (a) correct use of one log law (M1)
 x^{-2} OR x^2 OR $(2-x)(-2-x)$

$$(g(x) =) \frac{x^2 - 4}{x^2} \text{ OR } \frac{(2-x)(-2-x)}{x^2} \text{ OR } 1 - 4x^{-2} \text{ OR equivalent} \quad \text{A1}$$

[2 marks]

- (b) $f^{-1}(x) < -2$ OR $(-\infty, -2)$ A2

Note: Award **A1** for strictness with -2 using either $<$ or parenthesis and **A2** for completely correct inequality. Award **A2** for $y < -2$.

[2 marks]

- (c) attempt to exchange variables (seen anywhere) (M1)

$$x = \ln\left(\frac{y^2 - 4}{y^2}\right) \text{ OR } x = \ln(1 - 4y^{-2})$$

$$e^x = \frac{y^2 - 4}{y^2} \text{ OR } e^x = 1 - 4y^{-2} \quad \text{(A1)}$$

$$y^2(e^x - 1) = -4 \quad \text{(A1)}$$

$$(y =) \pm \frac{2}{\sqrt{1 - e^x}} \quad \text{A1}$$

(since domain of $f(x)$ is $x < -2$) $a = -2$ A1

[5 marks]

[Total 9 marks]

11. (a) (i) $(u_2 =) 6 + 6i$ A1

(ii) $(u_3 =) 8i$ A1

[2 marks]

(b) attempt to find $|r|$ (M1)

$$|r| = \sqrt{\left(\frac{2}{3}\right)^2 + \left(\frac{2}{3}\right)^2} \quad \text{A1}$$

$$|r| = \frac{2\sqrt{2}}{3} \quad \text{A1}$$

statement that multiplying a number by a complex number changes the modulus of the number by a factor of $|r|$ (may be seen at any stage) R1

Note: Award at most **(M1)A1A0R1** if common ratio is given as 0.942809.....

therefore it is a geometric sequence AG
[4 marks]

(c) substitution of their r and 9 into the sum formula for infinite sequence (A1)

$$S_\infty = \frac{9}{1 - \frac{2\sqrt{2}}{3}}$$

$(S_\infty =) 157 (157.367\dots, 81 + 54\sqrt{2})$ A1

Note: No **FT** if their $|r| \geq 1$.

[2 marks]
[Total 8 marks]

12. (a) correct shape that goes through point (0, 1)

A1

crosses the x -axis is at $x = -0.9$ (± 1 small grid box)

A1

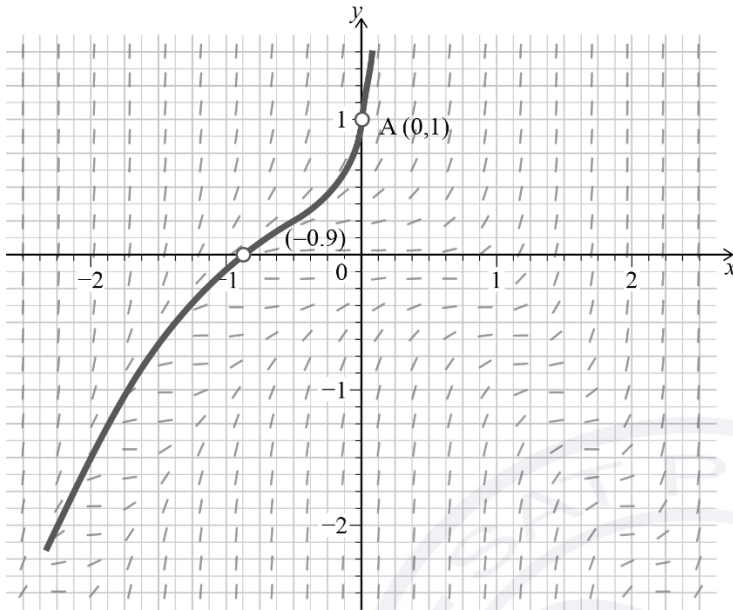

[2 marks]

(b) correct shape with maximum at (0, 0)

A1

smooth curve that goes approximately through points $(-2, -2)$ and $(2, -2)$

A1

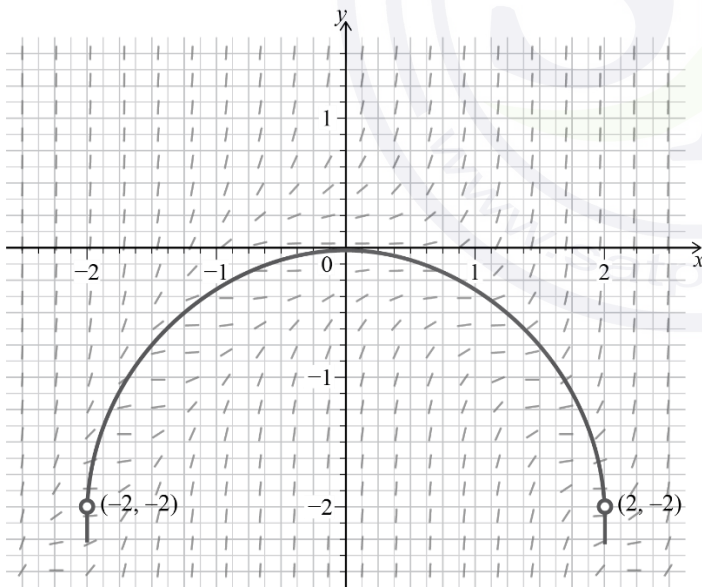

[2 marks]

(c) **EITHER**
substituting $y = ax^2$ into differential equation **(M1)**

$$0 = x^4 + 4x^2(ax^2) + 4(ax^2)^2$$

choosing an appropriate method to solve for a **(M1)**

$$0 = x^4(1 + 4a + 4a^2)$$

$$a = -\frac{1}{2} \quad \text{A1}$$

OR
 $x^4 + 4x^2y + 4y^2 = (x^2 + 2y)^2$ **(M1)**

$$(x^2 + 2y)^2 = 0 \quad \text{(M1)}$$

$$y = -\frac{1}{2}x^2 \text{ (so } a = -\frac{1}{2}\text{)} \quad \text{A1}$$

[3 marks]

[Total 7 marks]



13. (a) an anticlockwise/counter-clockwise rotation of $\frac{\pi}{3}$ (about the origin) **A1A1**

Note: Award **A1** for rotation and **A1** for correct angle/direction detail.

[2 marks]

- (b) attempt to multiply **A** and **B** in correct order **(M1)**

$$BA = \begin{bmatrix} -0.8 & 0.6 \\ 0.6 & 0.8 \end{bmatrix} \begin{bmatrix} \cos \frac{\pi}{3} & -\sin \frac{\pi}{3} \\ \sin \frac{\pi}{3} & \cos \frac{\pi}{3} \end{bmatrix} \left(\begin{bmatrix} -0.8 & 0.6 \\ 0.6 & 0.8 \end{bmatrix} \begin{bmatrix} 0.5 & -0.866025\dots \\ 0.866025\dots & 0.5 \end{bmatrix} \right)$$

$$\begin{bmatrix} 0.119615\dots & 0.992820\dots \\ 0.992820\dots & -0.119615\dots \end{bmatrix} \quad \text{(A1)}$$

attempt to create an expression with either $\tan 2\theta$ or $\sin 2\theta$ or $\cos 2\theta$ **(M1)**

$$\tan 2\theta = \frac{0.992820\dots}{0.119615\dots}$$

$$\theta = 0.725446\dots \quad \text{(A1)}$$

$$y = \tan(0.725446\dots)x$$

$$a = 0.887 \quad (0.886751\dots) \quad \text{A1}$$

Note: Award at most **(M1)(A1)(M1)(A1)A0** if the extraneous value of a is given alongside a correct answer.

[5 marks]

[Total 7 marks]

14. (a) $L_1(x) = \text{Im}(14.8e^{0.35xi}e^{1.27i})$ A1
 $L_2(x) = \text{Im}(18.5e^{0.35xi}e^{-2.36i})$ A1
[2 marks]

(b) $L_3 = \text{Im}(14.8e^{0.35xi}e^{1.27i} + 18.5e^{0.35xi}e^{-2.36i})$
 $L_3 = \text{Im}(e^{0.35xi}(14.8e^{1.27i} + 18.5e^{-2.36i}))$ (A1)

$L_3 = \text{Im}(e^{0.35xi}(8.81559\dots e^{3.01604\dots i}))$ (A1)

$L_3 = 8.81559\dots \sin(0.35x + 3.01604\dots)$
 $q = 8.82 (8.81559\dots), r = 3.02 (3.01604\dots)$ A1A1

Note: Award both marks if last line missing, but values are seen in equation for L_3 .

[4 marks]

[Total 6 marks]

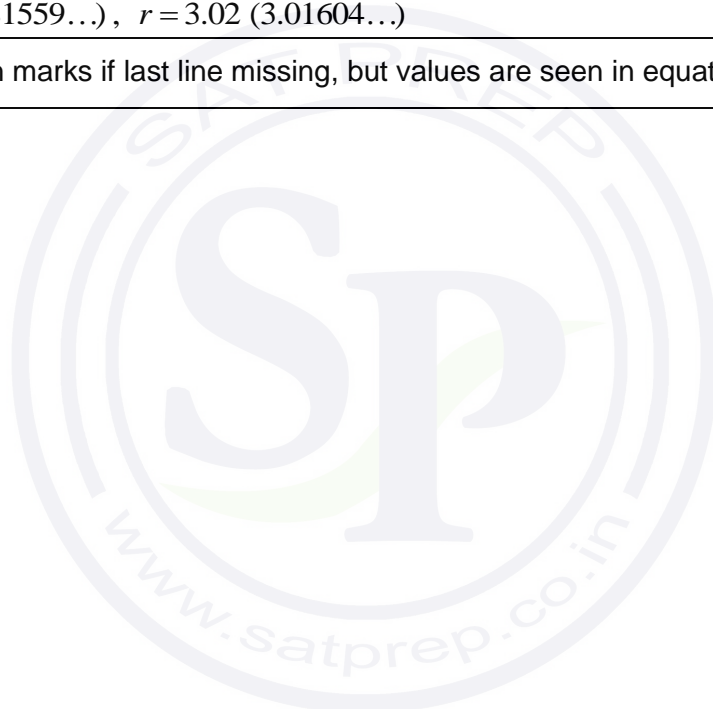

15. (a) (i) $x_{n+1} = x_n + 0.1 \left(\frac{dx}{dt} \right)_n$

$$\left(\frac{dx}{dt} \right)_{n+1} = \left(\frac{dx}{dt} \right)_n + 0.1 \left(\frac{d^2x}{dt^2} \right)_n \quad (M1)$$

$$\frac{d^2x}{dt^2} = 4.9 - 1.2 \frac{dx}{dt} - 4x \quad (A1)$$

$$\left(\frac{dx}{dt} \right)_{n+1} = \left(\frac{dx}{dt} \right)_n + 0.1 \left(4.9 - 1.2 \frac{dx}{dt} - 4x \right)_n \quad (A1)$$

(when $t = 1$ or $n = 10$) $x = 4.36$ (4.36332...) (m) A1

(ii) ($t =$) 2 (seconds) A1

Note: Award **A0** for either $n = 20$ or $t = 20$.

[5 marks]

(b) $x = 3.845$ seen **OR** $x = 3.855$ seen (A1)

substitution into percentage error formula using their value for part (a)(i) and 3.845 or 3.855 or 3.85 (M1)

$$\left| \frac{4.36332\dots - 3.845}{3.845} \right| \times 100$$

Note: Accept methods using centimetres instead of metres as long as both values use the same unit.

13.5 (13.4803...) (%) A1
[3 marks]

[Total 8 marks]

Markscheme

May 2025

**Mathematics: applications and
interpretation**

Higher level

Paper 1

© International Baccalaureate Organization 2025

All rights reserved. No part of this product may be reproduced in any form or by any electronic or mechanical means, including information storage and retrieval systems, without the prior written permission from the IB. Additionally, the license tied with this product prohibits use of any selected files or extracts from this product. Use by third parties, including but not limited to publishers, private teachers, tutoring or study services, preparatory schools, vendors operating curriculum mapping services or teacher resource digital platforms and app developers, whether fee-covered or not, is prohibited and is a criminal offense.

More information on how to request written permission in the form of a license can be obtained from <https://ibo.org/become-an-ib-school/ib-publishing/licensing/applying-for-a-license/>.

© Organisation du Baccalauréat International 2025

Tous droits réservés. Aucune partie de ce produit ne peut être reproduite sous quelque forme ni par quelque moyen que ce soit, électronique ou mécanique, y compris des systèmes de stockage et de récupération d'informations, sans l'autorisation écrite préalable de l'IB. De plus, la licence associée à ce produit interdit toute utilisation de tout fichier ou extrait sélectionné dans ce produit. L'utilisation par des tiers, y compris, sans toutefois s'y limiter, des éditeurs, des professeurs particuliers, des services de tutorat ou d'aide aux études, des établissements de préparation à l'enseignement supérieur, des fournisseurs de services de planification des programmes d'études, des gestionnaires de plateformes pédagogiques en ligne, et des développeurs d'applications, moyennant paiement ou non, est interdite et constitue une infraction pénale.

Pour plus d'informations sur la procédure à suivre pour obtenir une autorisation écrite sous la forme d'une licence, rendez-vous à l'adresse <https://ibo.org/become-an-ib-school/ib-publishing/licensing/applying-for-a-license/>.

© Organización del Bachillerato Internacional, 2025

Todos los derechos reservados. No se podrá reproducir ninguna parte de este producto de ninguna forma ni por ningún medio electrónico o mecánico, incluidos los sistemas de almacenamiento y recuperación de información, sin la previa autorización por escrito del IB. Además, la licencia vinculada a este producto prohíbe el uso de todo archivo o fragmento seleccionado de este producto. El uso por parte de terceros —lo que incluye, a título enunciativo, editoriales, profesores particulares, servicios de apoyo académico o ayuda para el estudio, colegios preparatorios, desarrolladores de aplicaciones y entidades que presten servicios de planificación curricular u ofrezcan recursos para docentes mediante plataformas digitales—, ya sea incluido en tasas o no, está prohibido y constituye un delito.

En este enlace encontrará más información sobre cómo solicitar una autorización por escrito en forma de licencia: <https://ibo.org/become-an-ib-school/ib-publishing/licensing/applying-for-a-license/>.

Instructions to Examiners

Abbreviations

- M** Marks awarded for attempting to use a correct **Method**.
- A** Marks awarded for an **Answer** or for **Accuracy**; often dependent on preceding **M** marks.
- R** Marks awarded for clear **Reasoning**.
- AG** Answer given in the question and so no marks are awarded.
- FT** Follow through. The practice of awarding marks, despite candidate errors in previous parts, for their correct methods/answers using incorrect results.

Using the markscheme

1 General

Award marks using the annotations as noted in the markscheme eg **M1**, **A2**.

2 Method and Answer/Accuracy marks

- Do **not** automatically award full marks for a correct answer; all working **must** be checked, and marks awarded according to the markscheme.
- It is generally not possible to award **M0** followed by **A1**, as **A** mark(s) depend on the preceding **M** mark(s), if any.
- Where **M** and **A** marks are noted on the same line, e.g. **M1A1**, this usually means **M1** for an **attempt** to use an appropriate method (e.g. substitution into a formula) and **A1** for using the **correct** values.
- Where there are two or more **A** marks on the same line, they may be awarded independently; so if the first value is incorrect, but the next two are correct, award **A0A1A1**.
- Where the markscheme specifies **A3**, **M2** etc., do **not** split the marks, unless there is a note.
- The response to a “show that” question does not need to restate the **AG** line, unless a **Note** makes this explicit in the markscheme.
- Once a correct answer to a question or part question is seen, ignore further working even if this working is incorrect and/or suggests a misunderstanding of the question. This will encourage a uniform approach to marking, with less examiner discretion. Although some candidates may be advantaged for that specific question item, it is likely that these candidates will lose marks elsewhere too.
- An exception to the previous rule is when an incorrect answer from further working is used **in a subsequent part**. For example, when a correct exact value is followed by an incorrect decimal approximation in the first part and this approximation is then used in the second part. In this situation, award **FT** marks as appropriate but do not award the final **A1** in the first part.

Examples:

	Correct answer seen	Further working seen	Any FT issues?	Action
1.	$8\sqrt{2}$	5.65685... <i>(incorrect decimal value)</i>	No. Last part in question.	Award A1 for the final mark <i>(condone the incorrect further working)</i>
2.	$\frac{35}{72}$	0.468111... <i>(incorrect decimal value)</i>	Yes. Value is used in subsequent parts.	Award A0 for the final mark <i>(and full FT is available in subsequent parts)</i>

3 Implied marks

Implied marks appear in **brackets e.g. (M1)**, and can only be awarded if **correct** work is seen or implied by subsequent working/answer.

4 Follow through marks (only applied after an error is made)

Follow through (**FT**) marks are awarded where an incorrect answer from one **part** of a question is used correctly in **subsequent** part(s) (e.g. incorrect value from part (a) used in part (d) or incorrect value from part (c)(i) used in part (c)(ii)). Usually, to award **FT** marks, **there must be working present** and not just a final answer based on an incorrect answer to a previous part. However, if all the marks awarded in a subsequent part are for the answer or are implied, then **FT** marks should be awarded for *their* correct answer, even when working is not present.

For example: following an incorrect answer to part (a) that is used in subsequent parts, where the markscheme for the subsequent part is **(M1)A1**, it is possible to award full marks for *their* correct answer, **without working being seen**. For longer questions where all but the answer marks are implied this rule applies but may be overwritten by a **Note** in the Markscheme.

- Within a question part, once an **error** is made, no further **A** marks can be awarded for work which uses the error, but **M** marks may be awarded if appropriate.
- If the question becomes much simpler because of an error then use discretion to award fewer **FT** marks, by reflecting on what each mark is for and how that maps to the simplified version.
- If the error leads to an inappropriate value (e.g. probability greater than 1, $\sin \theta = 1.5$, non-integer value where integer required), do not award the mark(s) for the final answer(s).
- The markscheme may use the word “their” in a description, to indicate that candidates may be using an incorrect value.
- If the candidate’s answer to the initial question clearly contradicts information given in the question, it is not appropriate to award any **FT** marks in the subsequent parts. This includes when candidates fail to complete a “show that” question correctly, and then in subsequent parts use their incorrect answer rather than the given value.

- Exceptions to these **FT** rules will be explicitly noted on the markscheme.
- If a candidate makes an error in one part but gets the correct answer(s) to subsequent part(s), award marks as appropriate, unless the command term was “Hence”.

5 Mis-read

If a candidate incorrectly copies values or information from the question, this is a mis-read (**MR**). A candidate should be penalized only once for a particular misread. Use the **MR** stamp to indicate that this has been a misread and do not award the first mark, even if this is an **M** mark, but award all others as appropriate.

- If the question becomes much simpler because of the **MR**, then use discretion to award fewer marks.
- If the **MR** leads to an inappropriate value (e.g. probability greater than 1, $\sin \theta = 1.5$, non-integer value where integer required), do not award the mark(s) for the final answer(s).
- Miscopying of candidates’ own work does **not** constitute a misread, it is an error.
- If a candidate uses a correct answer, to a “show that” question, to a higher degree of accuracy than given in the question, this is NOT a misread and full marks may be scored in the subsequent part.
- **MR** can only be applied when work is seen. For calculator questions with no working and incorrect answers, examiners should **not** infer that values were read incorrectly.

6 Alternative methods

Candidates will sometimes use methods other than those in the markscheme. Unless the question specifies a method, other correct methods should be marked in line with the markscheme. If the command term is ‘Hence’ and not ‘Hence or otherwise’ then alternative methods are not permitted unless covered by a note in the mark scheme.

- Alternative methods for complete questions are indicated by **METHOD 1**, **METHOD 2**, etc.
- Alternative solutions for parts of questions are indicated by **EITHER . . . OR**.

7 Alternative forms

Unless the question specifies otherwise, **accept** equivalent forms.

- As this is an international examination, accept all alternative forms of **notation** for example 1.9 and 1,9 or 1000 and 1,000 and 1.000.
- Do not accept final answers written using calculator notation. However, **M** marks and intermediate **A** marks can be scored, when presented using calculator notation, provided the evidence clearly reflects the demand of the mark.

- In the markscheme, equivalent **numerical** and **algebraic** forms will generally be written in brackets immediately following the answer.
- In the markscheme, some **equivalent** answers will generally appear in brackets. Not all equivalent notations/answers/methods will be presented in the markscheme and examiners are asked to apply appropriate discretion to judge if the candidate work is equivalent.

8 Format and accuracy of answers

If the level of accuracy is specified in the question, a mark will be linked to giving the answer to the required accuracy. If the level of accuracy is not stated in the question, the general rule applies to final answers: *unless otherwise stated in the question all numerical answers must be given exactly or correct to three significant figures.*

Where values are used in subsequent parts, the markscheme will generally use the exact value, however candidates may also use the correct answer to 3 sf in subsequent parts. The markscheme will often explicitly include the subsequent values that come “*from the use of 3 sf values*”.

Simplification of final answers: Candidates are advised to give final answers using good mathematical form. In general, for an **A** mark to be awarded, arithmetic should be completed, and any values that lead to integers should be simplified; for example, $\sqrt{\frac{25}{4}}$ should be written as $\frac{5}{2}$. An exception to this is simplifying fractions, where lowest form is not required (although the numerator and the denominator must be integers); for example, $\frac{10}{4}$ may be left in this form or written as $\frac{5}{2}$. However, $\frac{10}{5}$ should be written as 2, as it simplifies to an integer.

Algebraic expressions should be simplified by completing any operations such as addition and multiplication, e.g. $4e^{2x} \times e^{3x}$ should be simplified to $4e^{5x}$, and $4e^{2x} \times e^{3x} - e^{4x} \times e^x$ should be simplified to $3e^{5x}$. Unless specified in the question, expressions do not need to be factorized, nor do factorized expressions need to be expanded, so $x(x+1)$ and $x^2 + x$ are both acceptable.

Please note: intermediate **A** marks do NOT need to be simplified.

9 Calculators

A GDC is required for this paper, but if you see work that suggests a candidate has used any calculator not approved for IB DP examinations (eg CAS enabled devices), please follow the procedures for malpractice.

10. Presentation of candidate work

Crossed out work: If a candidate has drawn a line through work on their examination script, or in some other way crossed out their work, do not award any marks for that work unless an explicit note from the candidate indicates that they would like the work to be marked.

More than one solution: Where a candidate offers two or more different answers to the same question, an examiner should only mark the first response unless the candidate indicates otherwise. If the layout of the responses makes it difficult to judge, examiners should apply appropriate discretion to judge which is “first”.



1. (a) after 10 years

N: 120
I%: 3.6
PV: 0
PMT: (-)1500
P/Y: 12
C/Y: 12

(M1)(A1)

Note: Award (M1) for an attempt to use a financial app in their technology with at least two entries seen, award A1 for all entries correct except PV.

FV: 216 278.58 (euros)

A1

Note: Award A0 for a negative answer or answer not given to 2 decimal places.

[3 marks]

(b) **METHOD 1 (C.I. formula)**

invests: 116 278.58

(M1)

after 15 years: $116278.58 \times (1 + \frac{4.5}{400})^{60}$

(M1)(A1)

FV: 227 515.92 (euros)

A1

Note: Award the first M1 for subtracting their FV from part (a) even if the value of the investment is negative.

Award the second M1 for use of the C.I. formula.

Award first A1 for all entries correct except PV.

Allow full follow through from part (a).

Award final A0 for FV not given to 2 decimal places unless this has already been penalized in (a).

Accept 227 515.93 from use of unrounded value.

METHOD 2 (financial app)

invests: 116 278.58

(M1)

THEN

EITHER

N: 60
I%: 4.5
PV: 116 278.58
PMT: 0
P/Y: 4
C/Y: 4

OR

N: 15
I%: 4.5
PV: 116 278.58
PMT: 0
P/Y: 1
C/Y: 4

OR

N: 180
I%: 4.5
PV: 116 278.58
PMT: 0
P/Y: 12
C/Y: 4

(M1)(A1)

continued...

Question 1 continued

Note: Award the first **M1** for subtracting *their FV* from part (a) even if the value of the investment is negative.
Award (**M1**) for an attempt to use a financial app in their technology with a least two entries seen, award **A1** for all entries correct except *PV*.

THEN

FV: 227 515.92 (euros)

A1

Note: Award **A0** for a negative answer or answer not given to 2 decimal places unless already penalized in part (a).
Accept 227 515.93 from use of unrounded value.

[4 marks]
Total [7 marks]



2. (a) use of Pythagoras in 3 dimensions (M1)
 $AB^2 = 2^2 + 3^2 + 1^2$
 $AB = 3.74$ (= 3.74165... = $\sqrt{14}$) A1

[2 marks]

- (b) **METHOD 1 (using Pythagoras in 3D)**

$$1^2 + 6^2 + (k-1)^2 = 14 + 1^2 + 3^2 + (k-2)^2 \quad (M1)A1$$

Note: Award **M1** for use of Pythagoras in three dimensions, **A1** for correct use.

$$38 - 2k = 28 - 4k \quad (M1)$$

Note: Award **M1** for reducing equation to linear form.

$$k = -5 \quad A1$$

METHOD 2 (using vectors)

find the vectors \vec{AB} and \vec{CB} (M1)

$$\vec{AB} = \begin{pmatrix} 2 \\ 3 \\ 1 \end{pmatrix} \quad \vec{CB} = \begin{pmatrix} -1 \\ 3 \\ k-2 \end{pmatrix}$$

$$\begin{pmatrix} 2 \\ 3 \\ 1 \end{pmatrix} \cdot \begin{pmatrix} -1 \\ 3 \\ k-2 \end{pmatrix} = 0 \quad A1$$

calculate scalar product (M1)

$$-2 + 9 + k - 2 = 0$$

$$k = -5 \quad A1$$

[4 marks]

- (c) **EITHER**

$$\cos(\hat{BAC}) = \frac{\sqrt{14}}{\sqrt{73}} \quad (M1)(A1)$$

OR

$$\cos(\hat{BAC}) = \frac{\begin{pmatrix} 2 \\ 3 \\ 1 \end{pmatrix} \cdot \begin{pmatrix} 1 \\ 6 \\ -6 \end{pmatrix}}{\sqrt{14}\sqrt{73}} \quad (M1)(A1)$$

OR

$$\sin(\hat{BAC}) = \frac{\sqrt{59}}{\sqrt{73}} \quad (M1)(A1)$$

continued...

Question 2 continued

OR

$$\tan(\hat{BAC}) = \frac{\sqrt{59}}{\sqrt{14}}$$

(M1)(A1)

Note: Award **M1** for use of trig ratio, **A1** for correct use.

THEN

$$\hat{BAC} = 64.0^\circ \quad (64.0282\dots^\circ) \quad (1.12 (1.11750\dots))$$

A1

Note: Accept 64 for the final **A1**.

[3 marks]
Total [9 marks]



3. (a) 4
(b)

A1
[1 mark]

	A	B	C	D	E	F	G	H
Brett	1	4	2	3	5	6	7	8
Clarence	1	2	4	3	5	7	6	8

(A1)(A1)

Note: Award **(A1)** for each line in table

0.881 (0.880952...)

A2

Note: The ranks may be seen within printed table.
Award **A1** for 0.88 (2sf) answer.

For a common mistake:
Brett: 1 3 4 2 5 6 7 8 & Clarence correct
Award **(A0)(A1)A2FT** if 0.952 seen.

Note: The use of $r_s = 1 - \frac{6\sum d^2}{n(n-1)}$ i.e. $(r_s =) 1 - \frac{6(0^2 + 2^2 + 2^2 + 0^2 + 0^2 + 1^2 + 1^2 + 0^2)}{8(8^2 - 1)}$ may be

seen which is not in the syllabus, but is a valid method because there are no ties. As they need the table to get the differences, there is no change to MS for this method.

[4 marks]

- (c) (since r_s is close to 1) there is a strong (positive) correlation between the **rankings** of the sheepdogs by Brett and the **rankings** of the sheepdogs by Clarence (since r_s is close to 1) there is a strong (positive) association between Brett's **rankings** and Clarence's **rankings**.
since r_s is not equal to 1, Brett and Clarence do not always agree on the **rankings** of the sheepdogs.

A1

Note: For **A1** to be awarded, a numerical value must be seen in part (b), and the conclusion consistent with that numerical value.

“Strong positive” is insufficient because it is not in terms of the **ranks**.

“Similar” in isolation is insufficient, however if they state “the order in which the sheepdogs were **ranked** by the judges is similar” would be awarded **A1**.

The names of judges do not need to be seen for the **A** mark.

[1 mark]

Total [6 marks]

4. (a) (i) (8, 4) A1

Note: Do not condone the omission of parenthesis.

(ii) 5 A1

[2 marks]

(b) (i) 8 A1

(ii) **EITHER**
attempt to use Pythagoras theorem (M1)

$$4 + (b - 5)^2 = 9 + (9 - b)^2 \quad (A1)$$

$$(b =) \frac{61}{8} = 7.625 \quad \left(\frac{61}{8}, 7\frac{5}{8} \right) \quad A2$$

Note: Award **A1A0** for 7.63

OR

$$m(BD) = -\frac{4}{5} \quad (A1)$$

$$\text{midpoint } [BD] = (7.5, 7) \quad (A1)$$

Note: Gradient and midpoint may be implied by further working. Condone as interim coordinate 7.5, 7 instead of (7.5, 7).

$$(y - 7) = \frac{5}{4}(x - 7.5) \quad (M1)$$

substitute $x = 8$ in their perpendicular bisector

$$b - 7 = \frac{5}{4}(8 - 7.5)$$

$$(b =) 7.625 \quad \left(\frac{61}{8}, 7\frac{5}{8} \right) \quad A1$$

Note: Award **A1A1M1A0** final answer of 7.63

OR

$$m(DF) = -4 \quad (A1)$$

$$\text{midpoint } [DF] = (5.5, 7) \quad (A1)$$

Note: Gradient and midpoint may be implied by further working. Condone as interim coordinate 5.5, 7 instead of (5.5, 7)

continued...

Question 4 continued

$$(y - 7) = \frac{1}{4}(x - 5.5)$$

substitute $x = 8$ in their perpendicular bisector

(M1)

$$(8 - 7) = \frac{1}{4}(b - 5.5)$$

$$(b =) 7.625 \left(\frac{61}{8}, 7\frac{5}{8} \right)$$

A1

Note: Award **A1A1M1A0** final answer of 7.63

Note: Both a and b can be found by locating the intersection of two perpendicular bisectors.
This is an inefficient method, but correct answers should be awarded full marks.

[5 marks]

Total [7 marks]



5. use of $\text{speed} = \frac{\text{distance}}{\text{time}}$ **OR** $\text{speed} \times \text{time} = \text{distance}$ **OR** $\text{time} = \frac{\text{distance}}{\text{speed}}$

seen anywhere **(M1)**

attempt to find a bounding value of t (**OR** use appropriate values of t that support and contradict the statement that the car is speeding) **(M1)**

$(t =) 1.25(\text{s})$ **OR** $(t =) 1.15(\text{s})$ **(A1)**

THEN

EITHER

use of their upper bound for t to find minimum speed (**OR** of any value of t where $1.20481... < t \leq 1.25$ to find speed)

(speed =) $\frac{10}{1.25}$ (or $\frac{10}{\text{their time}}$) **A1**

(speed =) $8(\text{ms}^{-1})$ (or a value where $8 \leq \text{speed} < 8.3$) seen

hence speed $< 8.3(\text{ms}^{-1})$ **A1**

OR

use of their upper bound for t to find maximum distance (**OR** of any value of t where $1.20481... < t \leq 1.25$ to find distance)

(distance =) 8.3×1.25 (or $8.3 \times \text{their time}$) **A1**

(distance =) 10.375 m (or a value where $10 < \text{distance} \leq 10.375$) seen

hence distance $> 10(\text{m})$ **A1**

OR

time taken at speed limit (time =) $\frac{10}{8.3}$ **A1**

(time =) $1.20481...(\text{s})$

hence time of $1.2(\text{s})$ to the nearest $0.1(\text{s})$ could be greater than or less than this **A1**

THEN

conclusion: it is not certain that the car was exceeding the speed limit. **A1**

Note: The conclusion must have been justified by further showing that for some appropriate value of t the car is speeding
 Award at most **M1M1A0A1A0A1** for the use of a value of t where $t > 1.25$
 Award at most **M1M0A0A0A0A1** for $t = 1.2$ used with a corresponding justified conclusion.

Total [6 marks]

6. (a) attempt to use formula $S_{n-1}^2 = \frac{n}{n-1} S_n^2$ (M1)

$$= \frac{5}{4} \times 3.2^2$$

$$= 12.8 \text{ (}^\circ\text{C}^2\text{)}$$

A1
[2 marks]

(b) indication of use of t -interval (M1)

[16.1267, 24.0733] from use of 3.2
from GDC [15.7, 24.5] ([15.6577..., 24.5423...])

A1

Note: Do not penalize use of round brackets, strong inequalities or using terms such as “upper” and “lower” to describe the endpoints of the interval.

[2 marks]

(c) 17 is within the confidence interval, so it is a plausible mean

R1
[1 mark]
Total [5 marks]

7. (a) a valid/coherent attempt to use the substitution method (M1)

$$u = (-)x^2$$

$$\frac{du}{dx} = (-)2x$$

(A1)

Note: To award **M1**, both $u =$ and $\frac{du}{dx} =$ must be seen.

integral becomes

$$\frac{1}{2} \int e^{-u} du \text{ OR } -\frac{1}{2} \int e^u du$$

$$-\frac{1}{2} e^{-x^2} + c$$

(M1)

A1

Note: Award **M1A1M1A0** for a final answer of $-\frac{1}{2}e^{-x^2}$ with c omitted.

Accept integration by inspection, e.g. using $\frac{d}{dx}(e^{-x^2}) = -2xe^{-x^2}$

[4 marks]

(b) recognition that 0 is the lower limit (A1)

substituting both 0 and k into previous expression (M1)

$$\int_0^k xe^{-x^2} dx = \left[-\frac{1}{2}e^{-x^2} \right]_0^k$$

$$= \frac{1}{2} - \frac{1}{2}e^{-k^2}$$

A1

[3 marks]
Total [7 marks]

8. (a)

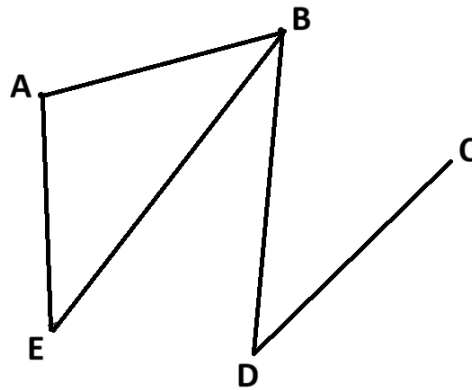

A2

[2 marks]

Note: For graphs with edges that cross each other but are otherwise correct, award **A1**.
Award **A2** for a directed graph where each edge is bi-directional.

(b) recognition that A^4 is required

(M1)

$$A^4 = \begin{pmatrix} 7 & 6 & 1 & 5 & 6 \\ 6 & 12 & 4 & 2 & 6 \\ 1 & 4 & 2 & 0 & 1 \\ 5 & 2 & 0 & 6 & 5 \\ 6 & 6 & 1 & 5 & 7 \end{pmatrix}$$

(A1)

recognition that diagonal entries are ones which return to the same town.
total of 34 walks

(M1)
A1

Note: For incomplete attempts to list all possible walks of length four award **M0A0M0A0**.

[4 marks]

Total [6 marks]

9. (a) **METHOD 1**

$A = xy$ **A1**

attempt to use product rule **M1**

$$\frac{dA}{dt} = x \frac{dy}{dt} + y \frac{dx}{dt}$$

$$75 \times (-5) + 40 \times 10$$

$$= 25 \text{ (km}^2 \text{/year)}$$
 A1

METHOD 2

$$\frac{dx}{dt} = 10, \quad \frac{dy}{dt} = -5$$

$$A = (10t + 75)(40 - 5t)$$
 A1

attempt to differentiate **M1**

$$\frac{dA}{dt} = 10(40 - 5t) - 5(10t + 75) \quad \text{OR} \quad \frac{dA}{dt} = -100t + 25$$

$$\left(\text{at } t = 0, \frac{dA}{dt} \right) = 25 \text{ (km}^2 \text{/year)}$$
 A1

[3 marks]

(b) increasing since the sign of $\frac{dA}{dt}$ is positive **R1**

[1 mark]

(c) new x is 85 and new y is 35, therefore new A is 2975 **A1**

old A was 3000 **A1**

therefore (a decrease of) 25 (km²) **A1**

Note: Accept an answer of $-25 \text{ (km}^2 \text{)}$

[3 marks]

Total [7 marks]

10. (a) 3

A1

[1 mark]

(b) 1

A1

[1 mark]

(c)

x	0	1	2	3	4
$f^{-1}(x)$	2	1	4	0	3

award **A1** for 1 correct, **A2** for 3 correct, **A3** for all 5 correct

A1A1A1

[3 marks]

Total [5 marks]

11. (a) 0, 1, 3

A2

Note: Award **A1** if either 1 or 3 is seen. Award **A1** for 0, 1000, 3000

[2 marks]

(b) sketching a graph or using calculus

(M1)

attempting to find the y coordinate at the local maximum

(M1)

local max occurs at (0.451416..., 0.631130...)

(A1)

$w > 0.631$

A1

[4 marks]

Total [6 marks]

12. (a) $\frac{dv}{dt} = kv^{1.5}$ A1
[1 mark]

(b) using initial condition to find an equation in k M1

$$-3 = k \times 8$$

$$k = -\frac{3}{8} (-0.375) \quad \text{A1}$$

attempt to separate variables M1

$$\int v^{-1.5} dv = \int -\frac{3}{8} dt$$

$$2v^{-0.5} = \frac{3}{8}t + c \quad (2v^{-0.5} = 0.375t + c) \quad \text{A1A1}$$

Note: Allow negative signs on each side.
 Award **A1** for each integral

using initial conditions to find constant of integration M1

$$c = 1 \quad \text{A1}$$

Note: Might be a different value of c depending on rearrangement.

$$v = \frac{1}{\left(\frac{3}{16}t + \frac{1}{2}\right)^2} \left(= \frac{256}{(3t+8)^2} \right) \left(= \frac{1}{(0.1875t+0.5)^2} \right) \quad \text{OE} \quad \text{A1}$$

[8 marks]
Total [9 marks]

13. let X be the number of worms in 1 square metre then $X \sim \text{Po}(1.2)$
- (a) $P(X = 1) = 0.361$ (0.361433...) **A1**
[1 mark]
- (b) $P(X \geq 1) = 0.699$ (0.698805...) **A1**
[1 mark]
- (c) if Y is the number of worms in 5 square metres then $Y \sim \text{Po}(6)$ **(A1)**
 $P(Y = 5) = 0.161$ (0.160623...) **A1**
[2 marks]
- (d) **EITHER**
- attempting to find an expression in terms of $P(X = 1)$ **(M1)**
 $P(X = 1)^5 = 0.00617$ (0.00616792...) **A1**
- OR**
- let V be the number of square metres containing exactly one worm **(M1)**
 attempting to use the binomial with $P(X = 1)$
 then $V \sim B(5, P(X = 1))$
 $P(V = 5) = 0.00617$ (0.00616792...) **A1**

Note: Accept 0.00613 from 3sf **FT** from part (a).

[2 marks]

- (e) let W be the number of square metres containing at least one worm. **(M1)**
 attempting to use binomial **(A1)**
 then $W \sim B(5, P(X \geq 1))$ **(A1)**
 $P(W = 3) = 0.310$ (0.309572...) **A1**

Note: Accept 0.31 for final **A1**. Accept 0.309 from 3sf **FT** from part (b).

[3 marks]

Total [9 marks]

14. use the second line since it has a higher R^2 **A1R1**

Note: Do not award **R0A1**. The **R1** can be awarded independently within the question.

$\ln w = 0.302 \ln d + 0.693$ **A1**

attempt to exponentiate both sides **M1**

$w = e^{0.693} \times d^{0.302}$ **A1**

$w = 2.00d^{0.302}$ ($= 1.99970\dots d^{0.302}$) **A1**

Note: Accept $w = 2d^{0.302}$ for final **A1**.
Award **A0R0A1M1A1A0** for use of the first line

Total [6 marks]



15. (a) attempt to find gradient (M1)

$$\frac{dy}{dx} = 2x$$

gradient of tangent is 4

gradient of normal is $-\frac{1}{4}$ (A1)

equation of normal is $y - 4 = -\frac{1}{4}(x - 2)$ $\left(y = -\frac{1}{4}x + \frac{9}{2} \right)$ OE A1

[3 marks]

(b) attempt to find gradient M1

gradient is $\frac{10 - 4}{0 - 2} = -3$ A1

[2 marks]

(c) **METHOD 1**

$\theta_1 = \arctan(-3)$ ($\approx -1.249, -71.57^\circ$) A1

$\theta_2 = \arctan\left(-\frac{1}{4}\right)$ ($\approx -0.2449, -14.04^\circ$) A1

Note: Award **A1A1** for $\arctan(3) - \arctan\left(\frac{1}{4}\right)$ OR $\arctan(-3) - \arctan\left(-\frac{1}{4}\right)$ seen

OR $\arctan\left(\frac{-3 - \left(-\frac{1}{4}\right)}{1 + (-3) \times \left(-\frac{1}{4}\right)}\right)$ OE.

difference between them is 1.00 (1.00407...) radians (57.5°) ($57.5288...^\circ$) A1

Note: Accept an obtuse angle between the normal and the ray. 2.14 (2.13752...) radians, 122° ($122.471...^\circ$).

continued...

Question 15 continued

METHOD 2

a point on the normal is $\left(0, \frac{9}{2}\right)$

A1

$(0,10)$

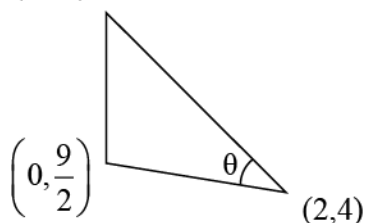

$$\cos \theta = \frac{2^2 + 6^2 + 2^2 + (0.5)^2 - (5.5)^2}{2\sqrt{4^2 + 1^2}\sqrt{1^2 + 3^2}}$$

A1

$$\theta = 1.00 (1.00407\dots)\text{radians } (57.5^\circ) (57.5288\dots^\circ)$$

A1

Note: Other points on the normal such as $(18, 0)$ may be seen

Note: Accept an obtuse angle between the normal and the ray. $2.14 (2.13752\dots)$ radians, $122^\circ (122.471\dots^\circ)$.

METHOD 3

writing the ray and normal as vectors

$$\begin{pmatrix} 2 \\ 4 \end{pmatrix} + \lambda \begin{pmatrix} -4 \\ 1 \end{pmatrix} \text{ and } \begin{pmatrix} 2 \\ 4 \end{pmatrix} + \mu \begin{pmatrix} -1 \\ 3 \end{pmatrix}$$

A1

the angle between them is given by

$$\cos \theta = \frac{\begin{pmatrix} -4 \\ 1 \end{pmatrix} \cdot \begin{pmatrix} -1 \\ 3 \end{pmatrix}}{\sqrt{(-4)^2 + 1^2}\sqrt{(-1)^2 + 3^2}}$$

A1

$$\theta = 1.00 (1.00407\dots)\text{radians } (57.5^\circ) (57.5288\dots^\circ)$$

A1

Note: Accept an obtuse angle between the normal and the ray. $2.14 (2.13752\dots)$ radians, $122^\circ (122.471\dots^\circ)$.

[3 marks]
Total [8 marks]

16. (a) an attempt to solve the equation for $t=1$ showing at least one of the solutions $z = -1 + i\sqrt{7}$ or $z = -1 - i\sqrt{7}$ **M1**
 required solution = $-1 + 2.65i$ ($= -1 + 2.64575...i$) ($= -1 + i\sqrt{7}$) **A1**
[2 marks]
- (b) using the quadratic formula **M1**
 $z = -t \pm \sqrt{t^2 - 8t}$
 $= -t \pm i\sqrt{8t - t^2}$ **A1**
 attempt to find $|z|^2$ **M1**
 $|z|^2 = t^2 + 8t - t^2 = 8t$ **A1**
 this is maximised when $t = 2$ **A1**
[5 marks]
Total [7 marks]



Markscheme

May 2025

**Mathematics: applications and
interpretation**

Higher level

Paper 1

© International Baccalaureate Organization 2025

All rights reserved. No part of this product may be reproduced in any form or by any electronic or mechanical means, including information storage and retrieval systems, without the prior written permission from the IB. Additionally, the license tied with this product prohibits use of any selected files or extracts from this product. Use by third parties, including but not limited to publishers, private teachers, tutoring or study services, preparatory schools, vendors operating curriculum mapping services or teacher resource digital platforms and app developers, whether fee-covered or not, is prohibited and is a criminal offense.

More information on how to request written permission in the form of a license can be obtained from <https://ibo.org/become-an-ib-school/ib-publishing/licensing/applying-for-a-license/>.

© Organisation du Baccalauréat International 2025

Tous droits réservés. Aucune partie de ce produit ne peut être reproduite sous quelque forme ni par quelque moyen que ce soit, électronique ou mécanique, y compris des systèmes de stockage et de récupération d'informations, sans l'autorisation écrite préalable de l'IB. De plus, la licence associée à ce produit interdit toute utilisation de tout fichier ou extrait sélectionné dans ce produit. L'utilisation par des tiers, y compris, sans toutefois s'y limiter, des éditeurs, des professeurs particuliers, des services de tutorat ou d'aide aux études, des établissements de préparation à l'enseignement supérieur, des fournisseurs de services de planification des programmes d'études, des gestionnaires de plateformes pédagogiques en ligne, et des développeurs d'applications, moyennant paiement ou non, est interdite et constitue une infraction pénale.

Pour plus d'informations sur la procédure à suivre pour obtenir une autorisation écrite sous la forme d'une licence, rendez-vous à l'adresse <https://ibo.org/become-an-ib-school/ib-publishing/licensing/applying-for-a-license/>.

© Organización del Bachillerato Internacional, 2025

Todos los derechos reservados. No se podrá reproducir ninguna parte de este producto de ninguna forma ni por ningún medio electrónico o mecánico, incluidos los sistemas de almacenamiento y recuperación de información, sin la previa autorización por escrito del IB. Además, la licencia vinculada a este producto prohíbe el uso de todo archivo o fragmento seleccionado de este producto. El uso por parte de terceros —lo que incluye, a título enunciativo, editoriales, profesores particulares, servicios de apoyo académico o ayuda para el estudio, colegios preparatorios, desarrolladores de aplicaciones y entidades que presten servicios de planificación curricular u ofrezcan recursos para docentes mediante plataformas digitales—, ya sea incluido en tasas o no, está prohibido y constituye un delito.

En este enlace encontrará más información sobre cómo solicitar una autorización por escrito en forma de licencia: <https://ibo.org/become-an-ib-school/ib-publishing/licensing/applying-for-a-license/>.

Instructions to Examiners

Abbreviations

- M** Marks awarded for attempting to use a correct **Method**.
- A** Marks awarded for an **Answer** or for **Accuracy**; often dependent on preceding **M** marks.
- R** Marks awarded for clear **Reasoning**.
- AG** Answer given in the question and so no marks are awarded.
- FT** Follow through. The practice of awarding marks, despite candidate errors in previous parts, for their correct methods/answers using incorrect results.

Using the markscheme

1 General

Award marks using the annotations as noted in the markscheme eg **M1**, **A2**.

2 Method and Answer/Accuracy marks

- Do **not** automatically award full marks for a correct answer; all working **must** be checked, and marks awarded according to the markscheme.
- It is generally not possible to award **M0** followed by **A1**, as **A** mark(s) depend on the preceding **M** mark(s), if any.
- Where **M** and **A** marks are noted on the same line, e.g. **M1A1**, this usually means **M1** for an **attempt** to use an appropriate method (e.g. substitution into a formula) and **A1** for using the **correct** values.
- Where there are two or more **A** marks on the same line, they may be awarded independently; so if the first value is incorrect, but the next two are correct, award **A0A1A1**.
- Where the markscheme specifies **A3**, **M2** etc., do **not** split the marks, unless there is a note.
- The response to a “show that” question does not need to restate the **AG** line, unless a **Note** makes this explicit in the markscheme.
- Once a correct answer to a question or part question is seen, ignore further working even if this working is incorrect and/or suggests a misunderstanding of the question. This will encourage a uniform approach to marking, with less examiner discretion. Although some candidates may be advantaged for that specific question item, it is likely that these candidates will lose marks elsewhere too.
- An exception to the previous rule is when an incorrect answer from further working is used **in a subsequent part**. For example, when a correct exact value is followed by an incorrect decimal approximation in the first part and this approximation is then used in the second part. In this situation, award **FT** marks as appropriate but do not award the final **A1** in the first part.

Examples:

	Correct answer seen	Further working seen	Any FT issues?	Action
1.	$8\sqrt{2}$	5.65685... (incorrect decimal value)	No. Last part in question.	Award A1 for the final mark (condone the incorrect further working)
2.	$\frac{35}{72}$	0.468111... (incorrect decimal value)	Yes. Value is used in subsequent parts.	Award A0 for the final mark (and full FT is available in subsequent parts)

3 Implied marks

Implied marks appear in **brackets e.g. (M1)**, and can only be awarded if **correct** work is seen or implied by subsequent working/answer.

4 Follow through marks (only applied after an error is made)

Follow through (**FT**) marks are awarded where an incorrect answer from one **part** of a question is used correctly in **subsequent** part(s) (e.g. incorrect value from part (a) used in part (d) or incorrect value from part (c)(i) used in part (c)(ii)). Usually, to award **FT** marks, **there must be working present** and not just a final answer based on an incorrect answer to a previous part. However, if all the marks awarded in a subsequent part are for the answer or are implied, then **FT** marks should be awarded for *their* correct answer, even when working is not present.

For example: following an incorrect answer to part (a) that is used in subsequent parts, where the markscheme for the subsequent part is **(M1)A1**, it is possible to award full marks for *their* correct answer, **without working being seen**. For longer questions where all but the answer marks are implied this rule applies but may be overwritten by a **Note** in the Markscheme.

- Within a question part, once an **error** is made, no further **A** marks can be awarded for work which uses the error, but **M** marks may be awarded if appropriate.
- If the question becomes much simpler because of an error then use discretion to award fewer **FT** marks, by reflecting on what each mark is for and how that maps to the simplified version.
- If the error leads to an inappropriate value (e.g. probability greater than 1, $\sin \theta = 1.5$, non-integer value where integer required), do not award the mark(s) for the final answer(s).
- The markscheme may use the word “their” in a description, to indicate that candidates may be using an incorrect value.
- If the candidate’s answer to the initial question clearly contradicts information given in the question, it is not appropriate to award any **FT** marks in the subsequent parts. This includes when candidates fail to complete a “show that” question correctly, and then in subsequent parts use their incorrect answer rather than the given value.
- Exceptions to these **FT** rules will be explicitly noted on the markscheme.
- If a candidate makes an error in one part but gets the correct answer(s) to subsequent part(s), award marks as appropriate, unless the command term was “Hence”.

5 Mis-read

If a candidate incorrectly copies values or information from the question, this is a mis-read (**MR**). A candidate should be penalized only once for a particular misread. Use the **MR** stamp to indicate that this has been a misread and do not award the first mark, even if this is an **M** mark, but award all others as appropriate.

- If the question becomes much simpler because of the **MR**, then use discretion to award fewer marks.
- If the **MR** leads to an inappropriate value (e.g. probability greater than 1, $\sin \theta = 1.5$, non-integer value where integer required), do not award the mark(s) for the final answer(s).
- Miscopying of candidates' own work does **not** constitute a misread, it is an error.
- If a candidate uses a correct answer, to a "show that" question, to a higher degree of accuracy than given in the question, this is NOT a misread and full marks may be scored in the subsequent part.
- **MR** can only be applied when work is seen. For calculator questions with no working and incorrect answers, examiners should **not** infer that values were read incorrectly.

6 Alternative methods

Candidates will sometimes use methods other than those in the markscheme. Unless the question specifies a method, other correct methods should be marked in line with the markscheme. If the command term is 'Hence' and not 'Hence or otherwise' then alternative methods are not permitted unless covered by a note in the mark scheme.

- Alternative methods for complete questions are indicated by **METHOD 1**, **METHOD 2**, etc.
- Alternative solutions for parts of questions are indicated by **EITHER . . . OR**.

7 Alternative forms

Unless the question specifies otherwise, **accept** equivalent forms.

- As this is an international examination, accept all alternative forms of **notation** for example 1.9 and 1,9 or 1000 and 1,000 and 1.000.
- Do not accept final answers written using calculator notation. However, **M** marks and intermediate **A** marks can be scored, when presented using calculator notation, provided the evidence clearly reflects the demand of the mark.
- In the markscheme, equivalent **numerical** and **algebraic** forms will generally be written in brackets immediately following the answer.
- In the markscheme, some **equivalent** answers will generally appear in brackets. Not all equivalent notations/answers/methods will be presented in the markscheme and examiners are asked to apply appropriate discretion to judge if the candidate work is equivalent.

8 Format and accuracy of answers

If the level of accuracy is specified in the question, a mark will be linked to giving the answer to the required accuracy. If the level of accuracy is not stated in the question, the general rule applies to final answers: *unless otherwise stated in the question all numerical answers must be given exactly or correct to three significant figures.*

Where values are used in subsequent parts, the markscheme will generally use the exact value, however candidates may also use the correct answer to 3 sf in subsequent parts. The markscheme will often explicitly include the subsequent values that come “*from the use of 3 sf values*”.

Simplification of final answers: Candidates are advised to give final answers using good mathematical form. In general, for an **A** mark to be awarded, arithmetic should be completed, and any values that lead to integers should be simplified; for example, $\sqrt{\frac{25}{4}}$ should be written as $\frac{5}{2}$. An exception to this is simplifying fractions, where lowest form is not required (although the numerator and the denominator must be integers); for example, $\frac{10}{4}$ may be left in this form or written as $\frac{5}{2}$.

However, $\frac{10}{5}$ should be written as 2, as it simplifies to an integer.

Algebraic expressions should be simplified by completing any operations such as addition and multiplication, e.g. $4e^{2x} \times e^{3x}$ should be simplified to $4e^{5x}$, and $4e^{2x} \times e^{3x} - e^{4x} \times e^x$ should be simplified to $3e^{5x}$. Unless specified in the question, expressions do not need to be factorized, nor do factorized expressions need to be expanded, so $x(x+1)$ and $x^2 + x$ are both acceptable.

Please note: intermediate **A** marks do NOT need to be simplified.

9 Calculators

A GDC is required for this paper, but if you see work that suggests a candidate has used any calculator not approved for IB DP examinations (eg CAS enabled devices), please follow the procedures for malpractice.

10. Presentation of candidate work

Crossed out work: If a candidate has drawn a line through work on their examination script, or in some other way crossed out their work, do not award any marks for that work unless an explicit note from the candidate indicates that they would like the work to be marked.

More than one solution: Where a candidate offers two or more different answers to the same question, an examiner should only mark the first response unless the candidate indicates otherwise. If the layout of the responses makes it difficult to judge, examiners should apply appropriate discretion to judge which is “first”.

Q1.

(a) attempt to use the cosine rule formula **(M1)**

$$(NV =) \sqrt{20^2 + 25^2 - 2 \times 20 \times 25 \cos 55.5^\circ} \quad \textbf{(A1)}$$

$$= 21.4(\text{m})(21.4148\dots) \quad \textbf{A1}$$

[3 marks]

(b) **EITHER**

attempt to use the sine rule formula **(M1)**

$$\frac{\sin \hat{P}\hat{N}\hat{V}}{25} = \frac{\sin 55.5^\circ}{21.4148\dots} \quad \textbf{(A1)}$$

OR

attempt to use the cosine rule formula **(M1)**

$$\cos \hat{P}\hat{N}\hat{V} = \frac{20^2 + 21.4148\dots^2 - 25^2}{2 \times 20 \times 21.4148\dots} \quad \textbf{(A1)}$$

THEN

$$\hat{P}\hat{N}\hat{V} = 74.2^\circ (74.1749\dots^\circ) \quad \textbf{A1}$$

[3 marks]

(c) recognition that shortest distance is perpendicular to NV **(M1)**
(may be seen on diagram)

use of right-angled triangle or other valid method **(M1)**

$$\sin 74.1749\dots \times 20 \quad \textbf{OR} \quad \frac{1}{2} \times 20 \times 25 \times \sin 55.5^\circ \times \frac{2}{21.4148\dots}$$

$$= 19.2(\text{m})(19.2419\dots) \quad \textbf{A1}$$

Note: Accept 19.3 (m) from using their 3 sf value in $\frac{1}{2} \times 20 \times 25 \times \sin 55.5^\circ \times \frac{2}{21.4148\dots}$

[3 marks]

Total [9 marks]

Q2.

(a) attempt to substitute the given values in the function **(M1)**

$$(L =) 10 \log_{10} \left(\frac{10^{-5}}{10^{-12}} \right)$$

$$= 70(\text{dB})$$

A1

[2 marks]

(b) $185 = 10 \log_{10} \left(\frac{I}{10^{-12}} \right)$ **(A1)**

attempt to solve their logarithmic equation using graph, solver or analytically **(M1)**

$$I = 3160000(\text{Wm}^{-2})(3162277.66)$$

$$I = 3.16 \times 10^6 (3.16227... \times 10^6)$$

A1

Note: Award at most **A1M1A0** or **A0M1A1FT** for an incorrect answer written correctly in the required form.

[3 marks]

Total [5 marks]

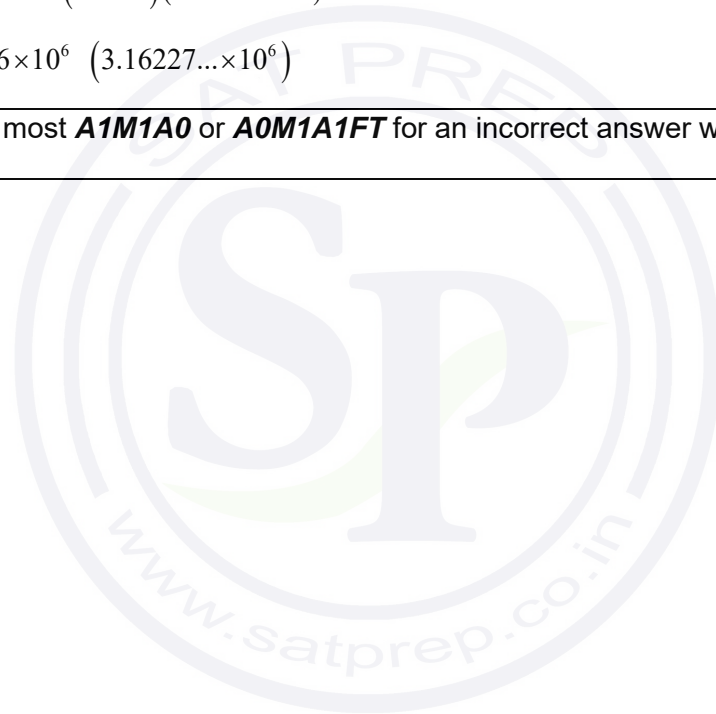

Q3.

(a) H_1 : satisfaction level and the type of service interaction are not independent. **A1**

[1 mark]

(b) 4 **A1**

[1 mark]

(c) 3.32 (3.31906...) **A2**

Note: Award **A1A0** for a 2 sf answer of 3.3 as recognition of correct method.

[2 marks]

(d) (i) $3.319106... < 9.488$ OR $0.506 (0.505917...) > 0.05$ **R1**

No, he isn't correct (insufficient evidence to reject H_0) **A1**

Note: Accept a comparison in words (e.g. $\chi^2_{calc} < \chi^2_{crit}$ or 'p-value < sig level') for the **R** mark only if their χ^2_{calc} value or p-value is seen. Do not award **A1R0**.

(ii) insufficient evidence to say "satisfaction level and the type of service interaction are not independent". **A1**

Note: Answer to part d (ii) follows through from their answer to part d(i).

[3 marks]

Total [7 marks]

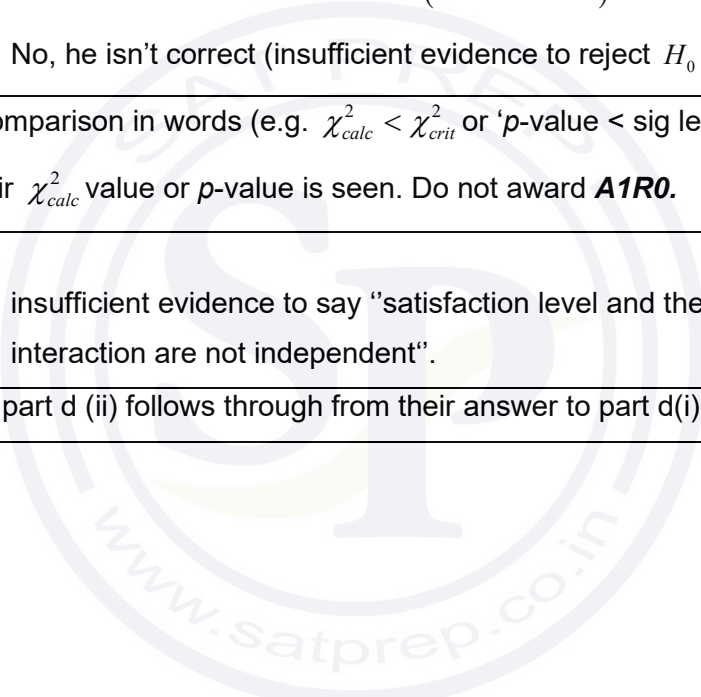

Q4.

- (a) 4 **A1**
[1 mark]
 (b) identification of lower quartile as 24.28 **(A1)**
 24.70 – 24.28

0.42 (seconds) **A1**
[2 marks]

- (c) (i) attempt to use correct formula to find boundaries for outliers **(M1)**
 $24.70 + 1.5 \times 0.42$ OR $24.28 - 1.5 \times 0.42$

25.33 and 23.65 **A1**

only 25.4 is an outlier **A1**

(ii)

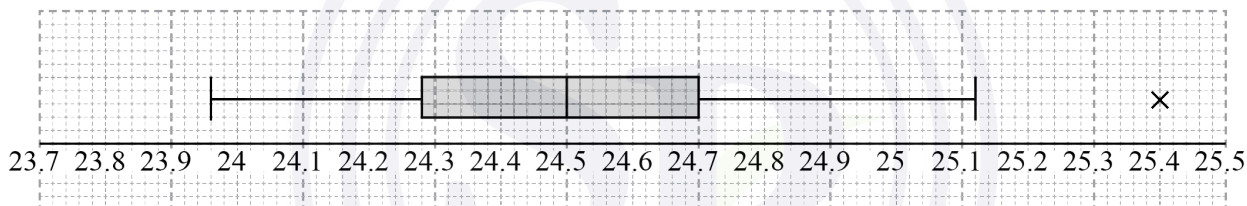

A1

Note: Award the **A1** only if both whiskers and the outlier are correctly marked.
 Accept symbols other than a cross to represent the outlier.
 The whiskers should not be drawn through the box.

[4 marks]
Total [7 marks]

Q5.

- (a) evidence of correct method **(M1)**

$$N = 300, I\% = 4.2, PV = \mp 50000, FV = 0, P/Y = 12, C/Y = 12 \text{ OR } 269.4711 \text{ seen}$$

Note: Award **M1** for using the financial app on their GDC with at least 2 correct entries.

269.47(euros) **A1**

Note: Award at most **(M1)A0** for -269.47 . Accept 269.48.

[2 marks]

- (b) (i) evidence of correct method $N = 96$ **(M1)**

$$N = 96, I\% = 4.2, PV = \mp 50000, PMT = \pm 269.47, P/Y = 12, C/Y = 12$$

OR

$$N = 96, I\% = 0.35, PV = \mp 50000, PMT = \pm 269.47, P/Y = 1, C/Y = 1$$

Note: Award **M1** for using the financial app on their GDC with at least 2 correct entries.

39, 243.42 **A1**

Note: Accept 39,243.29 which results from the full calculator value for the payment in part (a). Accept 39,243.28 which results from the use of 269.48.

Note: If two decimal place accuracy was penalised in part (a) do not penalise again.

- (ii) **METHOD 1**

full payment $12 \times 25 \times 269.47 = 80,841.00$ **(A1)**

actual payment $12 \times 8 \times 269.47 + 39243.42$ **(M1)**

$= 65, 112.54$ **(A1)**

money saved = 15,700 (15,728.46) (euros) **A1**

Note: Accept 15,728.59 from using 269.47 from part (a) and 39,243.29 from part (b)(i).
Accept 15,730.64 from using 269.48 from part (a) and 39,243.28 from part b(i).

continued

Question 5 continued

METHOD 2

if Sophie did not pay back the loan early her subsequent payments would be $269.47 \times 12 \times 17$ **(M1)**

Note: Award **M1** for attempting to find the remaining amount to pay if loan not paid back.

= 54971.88 (euros) **(A1)**

money saved is therefore
 $54971.88 - 39243.42$ **(M1)**

= 15,700(15,728.46) (euros) **A1**

[6 marks]
Total [8 marks]

Q6

(a) use of formula for sum of an arithmetic sequence or first few terms seen **(M1)**

$$\frac{10}{2}(2 \times 6 + 9 \times 3) \text{ OR } 6 + 9 + 12 + 15 + \dots$$

sum of angles is 195° **(A1)**

$$p = \frac{195}{360} \left(0.542, \frac{13}{24}, 0.541666\dots \right) \quad \text{A1}$$

[3 marks]

(b) recognition of binomial distribution **(M1)**

$$n = 4, p = \frac{195}{360} \text{ OR } X \sim B\left(4, \frac{195}{360}\right) \quad \text{(A1)}$$

let X be the number of times the arrow lands in white

$$P(X \geq 3) = 0.377 \text{ (0.377450\dots)} \quad \text{A1}$$

Note: Accept 0.378 (0.377988...) from use of 0.542 from part (a).

[3 marks]
Total [6 marks]

Q7.

(a) stratified (sampling)

A1
[1 mark]

(b) (i) $r = 0.854$ (0.853899...)

A2

Note: Award **(M1)A0** for a truncated value $r = 0.853$ or incorrectly rounded value eg. $r = 0.85$.

(ii) it is valid (since $r > 0.8$)

A1

Note: Follow through from their value of r , for the final **A1**.

[3 marks]

(c) $y = 0.266x + 2.40$ ($y = 0.265851...x + 2.39573...$)

A1

Note: Accept 2.4.

(d) substitution of 17.2 into their regression line
 $y = 0.265851... \times 17.2 + 2.39573...$
 $= 6.97$ (6.96837...)

[1 mark]
(M1)

A1

Note: Accept 6.98 (6.9752) from use of 3sf answers from part (c).

[2 marks]

Total [7 marks]

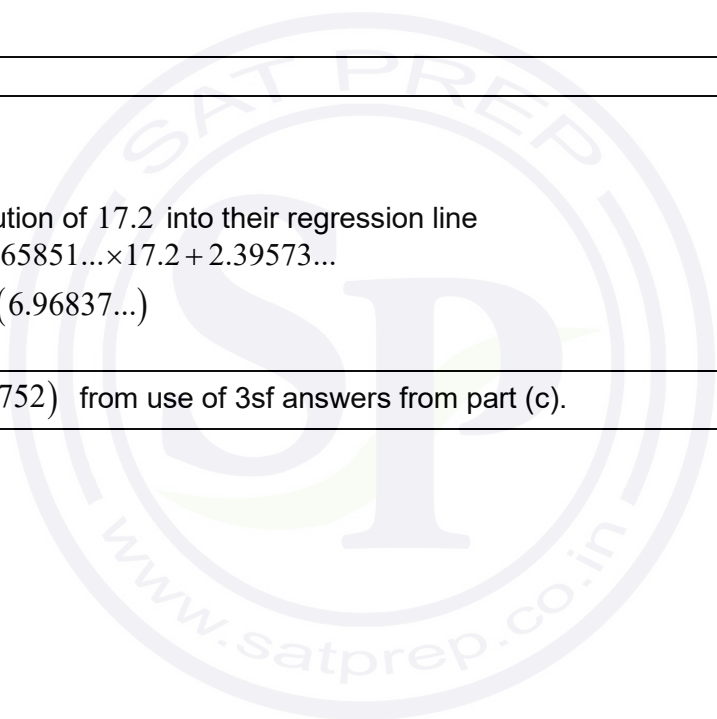

Q8. EITHER
attempt to find matrix for compound transformation **(M1)**

$$\begin{pmatrix} 3 & 1 \\ 0 & 1 \end{pmatrix} \begin{pmatrix} 0 & 1 \\ 1 & 0 \end{pmatrix} = \begin{pmatrix} 1 & 3 \\ 1 & 0 \end{pmatrix} \quad \text{(A1)}$$

$$\begin{pmatrix} 1 & 3 \\ 1 & 0 \end{pmatrix} \begin{pmatrix} x \\ y \end{pmatrix} = \begin{pmatrix} 4 \\ 7 \end{pmatrix} \quad \text{(A1)}$$

multiply by the inverse(s) or form two equations **(M1)**

OR

$$\begin{pmatrix} 3 & 1 \\ 0 & 1 \end{pmatrix} \begin{pmatrix} b_1 \\ b_2 \end{pmatrix} = \begin{pmatrix} 4 \\ 7 \end{pmatrix} \quad \text{(A1)}$$

multiply by the inverse or form two equations **(M1)**

coordinates of B are $(-1, 7)$ **(A1)**

attempt to find coordinates for A by setting up matrix **(M1)**

$$\begin{pmatrix} 0 & 1 \\ 1 & 0 \end{pmatrix} \begin{pmatrix} a_1 \\ a_2 \end{pmatrix} = \begin{pmatrix} -1 \\ 7 \end{pmatrix}$$

THEN

$(7, -1)$ **A1**

Total [5 marks]

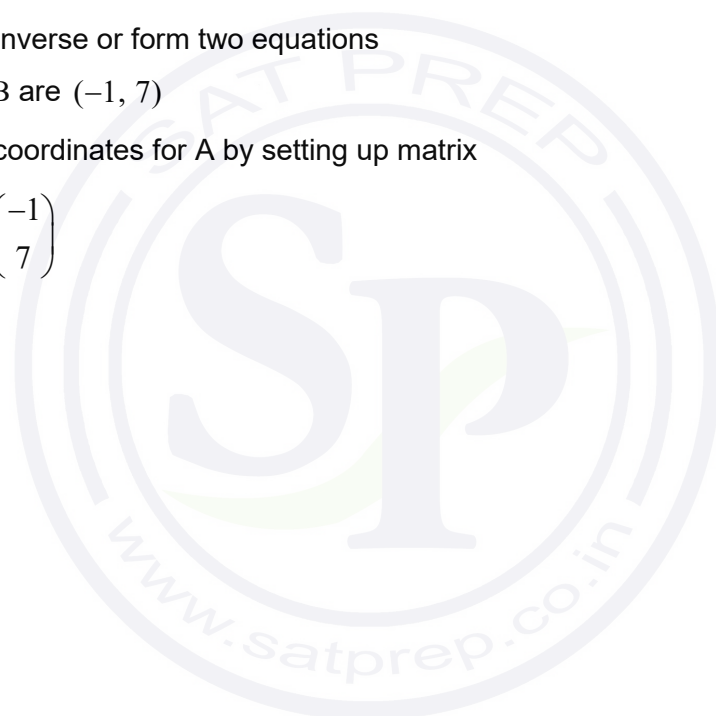

- Q9** (a) attempt to use product rule, two terms with one term correct (M1)
 attempt to use the chain rule to find the derivative of $\sqrt{3x-2}$ (M1)

$$\frac{dy}{dx} = 4(3x-2)^{0.5} + 4x \times \frac{3}{2}(3x-2)^{-0.5} \quad \text{A1}$$

$$\left(= 4(3x-2)^{0.5} + 6x(3x-2)^{-0.5} \right) \left(= \frac{2(9x-4)}{\sqrt{3x-2}} \right)$$

[3 marks]

- (b) substitution of $x = 6$ into their $\frac{dy}{dx}$ (M1)

gradient of tangent = $(16 + 9 =) 25$ A1

Note: Follow through for this **A1** from their $\frac{dy}{dx}$.

at $(6, 96)$ tangent is

EITHER

$$y - 96 = 25(x - 6)$$

A1

OR

$$96 = 25 \times 6 + c$$

A1

Note: Do not allow follow through for this **A1**.

THEN

$$y = 25x - 54$$

AG

[3 marks]

Total [6 marks]

- Q10.** (a) (i) $F = \frac{k}{d^2}$ (A1)
 substitution of d and F into their equation (M1)
 $40000 = \frac{k}{7000^2}$
 $k = 1.96 \times 10^{12}$
 $F = \frac{1.96 \times 10^{12}}{d^2}$ A1
- (ii) $F = \frac{1.96 \times 10^{12}}{3500^2}$
 160000 (N) A1
[4 marks]
- (b) (i) C A1
 D A1

Note: Award at most **A1A0** if an additional incorrect answer is given.

- (ii) for C the gradient is $k = 1.96 \times 10^{12}$ A1
 for D the gradient is -2 A1
[4 marks]
Total [8 marks]

- Q11.** (a) C A1
[1 mark]
- (b) attempting to substitute values into the correct formulae (M1)
 $x_{n+1} = x_n + 0.1(3x_n - 2y_n)$, $y_{n+1} = y_n + 0.1(4x_n - y_n)$ (A1)
 $(t_{n+1} = t_n + 0.1)$
 any correct value for x_{n+1} and y_{n+1} for $n = 2, 3, \dots$ (A1)

n	t	x	y
0	5	1	0
1	5.1	1.3	0.4
2	5.2	1.61	0.88
3	5.3	1.917	1.436
4	5.4	2.2049	2.0592

$x = 2.45$ (2.45453...) A1

Note: Accept $x = 2.455$ from rounding to 4 sf.

$y = 2.74$ (2.73524...) A1
[5 marks]
Total [6 marks]

- Q12.** (a) (i) rejecting the null hypothesis when it is true **A1**
OR
rejecting the mean as 12.4 / min (124 / 10 mins) when it is true **A1**
- (ii) let X be the number of cars that arrive in 10 minutes
attempt to find $P(X \geq 131)$ **(M1)**
use of $Po(124)$ **(M1)**
 $P(X \geq 131) = 0.276$ (0.276397...) **A1**
[4 marks]
- (b) any valid reason **R1**
for example:
the arrival of cars are not independent (there might be a traffic light shortly before the intersection)
the rate of arrival is not uniform (some times of day might be busier than others)

Note: Do not accept "mean and variance are not the same".

[1 mark]
Total [5 marks]

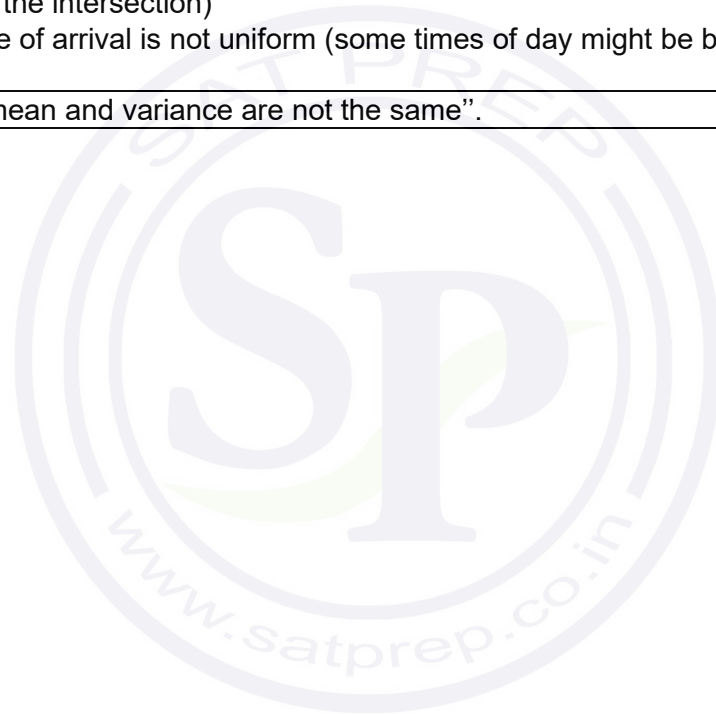

- Q13.** (a) $\frac{dP}{dt} = 0.2(1 - P)$
 attempt to separate variables **M1**
 $\int \frac{1}{1 - P} dP = \int 0.2 dt$
 attempt to integrate left hand side by substitution or inspection. **(M1)**

Note: The **(M1)** may be awarded if their LHS is $\ln(1 - P)$ without the minus.

$$-\ln(1 - P) = 0.2t (+c) \quad \text{A1A1}$$

Note: Modulus sign not required as $0 \leq P < 1$.

EITHER

substitution of $P = 0$ when $t = 0$ **M1**

$$-\ln(1 - 0) = 0.2(0) + c \Rightarrow c = 0 \quad \text{A1}$$

eliminating the natural logarithm **M1**

$$1 - P = e^{-0.2t}$$

OR

eliminating the natural logarithm **M1**

$$1 - P = e^{-0.2t - c} \text{ or } 1 - P = Ae^{-0.2t}$$

substitution of $P = 0$ when $t = 0$ **M1**

$$1 = e^{-c} \Rightarrow c = 0 \text{ OR } 1 = A \quad \text{A1}$$

THEN

$$P = 1 - e^{-0.2t} \quad \text{AG}$$

[7 marks]

- (b) attempt to solve $0.9 = 1 - e^{-0.2t}$ **(M1)**

11.5 (days) (11.5129...)
A1

[2 marks]
Total [9 marks]

Q14. (a) $\begin{pmatrix} \dot{x} \\ \dot{y} \end{pmatrix} = \begin{pmatrix} -20 \\ -9.8t \end{pmatrix}$ **A1A1**

[2 marks]

(b) $\begin{pmatrix} x \\ y \end{pmatrix} = \begin{pmatrix} -20t + d \\ -4.9t^2 + 70 \end{pmatrix}$ **(A1)(A1)**

recognition that package hits the ground when $-4.9t^2 + 70 = 0$ **(M1)**

$t^2 = \frac{70}{4.9} \Rightarrow t = 3.77964... \text{seconds}$ **(A1)**

attempt to solve $-20t + d = 0$ **(M1)**

$d = 20 \times 3.7796...$

distance $d = 75.6$ (75.5928...) (m) **A1**

[6 marks]

Total [8 marks]

Q15. (a) $\begin{pmatrix} p-1 & 1-q \\ 1-p & q-1 \end{pmatrix} \begin{pmatrix} x \\ y \end{pmatrix} = \begin{pmatrix} 0 \\ 0 \end{pmatrix}$ or $\begin{pmatrix} p & 1-q \\ 1-p & q \end{pmatrix} \begin{pmatrix} x \\ y \end{pmatrix} = \begin{pmatrix} x \\ y \end{pmatrix}$ **(M1)**

$(p-1)x + (1-q)y = 0$ (or equivalent) **(A1)**

$\begin{pmatrix} 1-q \\ 1-p \end{pmatrix}$ (or any multiple) **A1**

[3 marks]

(b) $\frac{1-q}{2-p-q}$ **A1A1**

Note: Award **A1** for numerator, **A1** for denominator.
For an answer of $1-q$ only, award **A0A0**.

[2 marks]

(c) $\frac{4}{11}(0.364, 0.363636...)$ **A1**

[1 mark]

Total [6 marks]

Q16. (a) $g(x) = 4 \cos\left(\frac{\pi}{8}(x+0.3)\right) - 0.2$ **A1A1**

Note: Accept $g(x) = f(x+0.3) - 0.2$

[2 marks]

(b) 3.57 (3.57262...) **A1**
[1 mark]

(c) (i) use of formula for volume in at least one integral **M1**

Note: In this formula condone one of:
missing or incorrect limits, absence of π , absence of dx for the **M1**.

subtracting two volumes **M1**

$$\frac{\pi}{2} \int_0^4 \left(4 \cos\left(\frac{\pi}{8}x\right)\right)^2 dx - \frac{\pi}{2} \int_0^{3.57262\dots} \left(4 \cos\left(\frac{\pi}{8}(x+0.3)\right) - 0.2\right)^2 dx$$
A1A1

Note: Award **A1** for each completely correct expression (including the dx).
Award **A1A0** for everything correct except not dividing by two.

(ii) $\frac{\pi}{2}(32 - 23.7729\dots)$
12.9 cm³ (12.9229...) **A1**

Note: Do not award **A1FT** follow through for this part.

[5 marks]
Total [8 marks]

Markscheme

November 2024

**Mathematics:
applications and interpretation**

Higher level

Paper 1

© International Baccalaureate Organization 2024

All rights reserved. No part of this product may be reproduced in any form or by any electronic or mechanical means, including information storage and retrieval systems, without the prior written permission from the IB. Additionally, the license tied with this product prohibits use of any selected files or extracts from this product. Use by third parties, including but not limited to publishers, private teachers, tutoring or study services, preparatory schools, vendors operating curriculum mapping services or teacher resource digital platforms and app developers, whether fee-covered or not, is prohibited and is a criminal offense.

More information on how to request written permission in the form of a license can be obtained from <https://ibo.org/become-an-ib-school/ib-publishing/licensing/applying-for-a-license/>.

© Organisation du Baccalauréat International 2024

Tous droits réservés. Aucune partie de ce produit ne peut être reproduite sous quelque forme ni par quelque moyen que ce soit, électronique ou mécanique, y compris des systèmes de stockage et de récupération d'informations, sans l'autorisation écrite préalable de l'IB. De plus, la licence associée à ce produit interdit toute utilisation de tout fichier ou extrait sélectionné dans ce produit. L'utilisation par des tiers, y compris, sans toutefois s'y limiter, des éditeurs, des professeurs particuliers, des services de tutorat ou d'aide aux études, des établissements de préparation à l'enseignement supérieur, des fournisseurs de services de planification des programmes d'études, des gestionnaires de plateformes pédagogiques en ligne, et des développeurs d'applications, moyennant paiement ou non, est interdite et constitue une infraction pénale.

Pour plus d'informations sur la procédure à suivre pour obtenir une autorisation écrite sous la forme d'une licence, rendez-vous à l'adresse <https://ibo.org/become-an-ib-school/ib-publishing/licensing/applying-for-a-license/>.

© Organización del Bachillerato Internacional, 2024

Todos los derechos reservados. No se podrá reproducir ninguna parte de este producto de ninguna forma ni por ningún medio electrónico o mecánico, incluidos los sistemas de almacenamiento y recuperación de información, sin la previa autorización por escrito del IB. Además, la licencia vinculada a este producto prohíbe el uso de todo archivo o fragmento seleccionado de este producto. El uso por parte de terceros —lo que incluye, a título enunciativo, editoriales, profesores particulares, servicios de apoyo académico o ayuda para el estudio, colegios preparatorios, desarrolladores de aplicaciones y entidades que presten servicios de planificación curricular u ofrezcan recursos para docentes mediante plataformas digitales—, ya sea incluido en tasas o no, está prohibido y constituye un delito.

En este enlace encontrará más información sobre cómo solicitar una autorización por escrito en forma de licencia: <https://ibo.org/become-an-ib-school/ib-publishing/licensing/applying-for-a-license/>.

Instructions to Examiners

Abbreviations

- M** Marks awarded for attempting to use a correct **Method**.
- A** Marks awarded for an **Answer** or for **Accuracy**; often dependent on preceding **M** marks.
- R** Marks awarded for clear **Reasoning**.
- AG** Answer given in the question and so no marks are awarded.
- FT** Follow through. The practice of awarding marks, despite candidate errors in previous parts, for their correct methods/answers using incorrect results.

Using the markscheme

1 General

Award marks using the annotations as noted in the markscheme eg **M1**, **A2**.

2 Method and Answer/Accuracy marks

- Do **not** automatically award full marks for a correct answer; all working **must** be checked, and marks awarded according to the markscheme.
- It is generally not possible to award **M0** followed by **A1**, as **A** mark(s) depend on the preceding **M** mark(s), if any.
- Where **M** and **A** marks are noted on the same line, e.g. **M1A1**, this usually means **M1** for an **attempt** to use an appropriate method (e.g. substitution into a formula) and **A1** for using the **correct** values.
- Where there are two or more **A** marks on the same line, they may be awarded independently; so if the first value is incorrect, but the next two are correct, award **A0A1A1**.
- Where the markscheme specifies **A3**, **M2** etc., do **not** split the marks, unless there is a note.
- The response to a “show that” question does not need to restate the **AG** line, unless a **Note** makes this explicit in the markscheme.
- Once a correct answer to a question or part question is seen, ignore further working even if this working is incorrect and/or suggests a misunderstanding of the question. This will encourage a uniform approach to marking, with less examiner discretion. Although some candidates may be advantaged for that specific question item, it is likely that these candidates will lose marks elsewhere too.
- An exception to the previous rule is when an incorrect answer from further working is used **in a subsequent part**. For example, when a correct exact value is followed by an incorrect decimal approximation in the first part and this approximation is then used in the second part. In this situation, award **FT** marks as appropriate but do not award the final **A1** in the first part.

Examples:

	Correct answer seen	Further working seen	Any FT issues?	Action
1.	$8\sqrt{2}$	5.65685... (incorrect decimal value)	No. Last part in question.	Award A1 for the final mark (condone the incorrect further working)
2.	$\frac{35}{72}$	0.468111... (incorrect decimal value)	Yes. Value is used in subsequent parts.	Award A0 for the final mark (and full FT is available in subsequent parts)

3 Implied marks

Implied marks appear in **brackets e.g. (M1)**, and can only be awarded if **correct** work is seen or implied by subsequent working/answer.

4 Follow through marks (only applied after an error is made)

Follow through (**FT**) marks are awarded where an incorrect answer from one **part** of a question is used correctly in **subsequent** part(s) (e.g. incorrect value from part (a) used in part (d) or incorrect value from part (c)(i) used in part (c)(ii)). Usually, to award **FT** marks, **there must be working present** and not just a final answer based on an incorrect answer to a previous part. However, if all the marks awarded in a subsequent part are for the answer or are implied, then **FT** marks should be awarded for *their* correct answer, even when working is not present.

For example: following an incorrect answer to part (a) that is used in subsequent parts, where the markscheme for the subsequent part is **(M1)A1**, it is possible to award full marks for *their* correct answer, **without working being seen**. For longer questions where all but the answer marks are implied this rule applies but may be overwritten by a **Note** in the Markscheme.

- Within a question part, once an **error** is made, no further **A** marks can be awarded for work which uses the error, but **M** marks may be awarded if appropriate.
- If the question becomes much simpler because of an error then use discretion to award fewer **FT** marks, by reflecting on what each mark is for and how that maps to the simplified version.
- If the error leads to an inappropriate value (e.g. probability greater than 1, $\sin \theta = 1.5$, non-integer value where integer required), do not award the mark(s) for the final answer(s).
- The markscheme may use the word “their” in a description, to indicate that candidates may be using an incorrect value.
- If the candidate’s answer to the initial question clearly contradicts information given in the question, it is not appropriate to award any **FT** marks in the subsequent parts. This includes when candidates fail to complete a “show that” question correctly, and then in subsequent parts use their incorrect answer rather than the given value.
- Exceptions to these **FT** rules will be explicitly noted on the markscheme.
- If a candidate makes an error in one part but gets the correct answer(s) to subsequent part(s), award marks as appropriate, unless the command term was “Hence”.

5 Mis-read

If a candidate incorrectly copies values or information from the question, this is a mis-read (**MR**). A candidate should be penalized only once for a particular misread. Use the **MR** stamp to indicate that this has been a misread and do not award the first mark, even if this is an **M** mark, but award all others as appropriate.

- If the question becomes much simpler because of the **MR**, then use discretion to award fewer marks.
- If the **MR** leads to an inappropriate value (e.g. probability greater than 1, $\sin \theta = 1.5$, non-integer value where integer required), do not award the mark(s) for the final answer(s).
- Miscopying of candidates' own work does **not** constitute a misread, it is an error.
- If a candidate uses a correct answer, to a "show that" question, to a higher degree of accuracy than given in the question, this is NOT a misread and full marks may be scored in the subsequent part.
- **MR** can only be applied when work is seen. For calculator questions with no working and incorrect answers, examiners should **not** infer that values were read incorrectly.

6 Alternative methods

Candidates will sometimes use methods other than those in the markscheme. Unless the question specifies a method, other correct methods should be marked in line with the markscheme. If the command term is 'Hence' and not 'Hence or otherwise' then alternative methods are not permitted unless covered by a note in the mark scheme.

- Alternative methods for complete questions are indicated by **METHOD 1**, **METHOD 2**, etc.
- Alternative solutions for parts of questions are indicated by **EITHER . . . OR**.

7 Alternative forms

Unless the question specifies otherwise, **accept** equivalent forms.

- As this is an international examination, accept all alternative forms of **notation** for example 1.9 and 1,9 or 1000 and 1,000 and 1.000.
- Do not accept final answers written using calculator notation. However, **M** marks and intermediate **A** marks can be scored, when presented using calculator notation, provided the evidence clearly reflects the demand of the mark.
- In the markscheme, equivalent **numerical** and **algebraic** forms will generally be written in brackets immediately following the answer.
- In the markscheme, some **equivalent** answers will generally appear in brackets. Not all equivalent notations/answers/methods will be presented in the markscheme and examiners are asked to apply appropriate discretion to judge if the candidate work is equivalent.

8 Format and accuracy of answers

If the level of accuracy is specified in the question, a mark will be linked to giving the answer to the required accuracy. If the level of accuracy is not stated in the question, the general rule applies to final answers: *unless otherwise stated in the question all numerical answers must be given exactly or correct to three significant figures.*

Where values are used in subsequent parts, the markscheme will generally use the exact value, however candidates may also use the correct answer to 3 sf in subsequent parts. The markscheme will often explicitly include the subsequent values that come “*from the use of 3 sf values*”.

Simplification of final answers: Candidates are advised to give final answers using good mathematical form. In general, for an **A** mark to be awarded, arithmetic should be completed, and

any values that lead to integers should be simplified; for example, $\sqrt{\frac{25}{4}}$ should be written as $\frac{5}{2}$.

An exception to this is simplifying fractions, where lowest form is not required (although the numerator and the denominator must be integers); for example, $\frac{10}{4}$ may be left in this form or

written as $\frac{5}{2}$. However, $\frac{10}{5}$ should be written as 2, as it simplifies to an integer.

Algebraic expressions should be simplified by completing any operations such as addition and multiplication, e.g. $4e^{2x} \times e^{3x}$ should be simplified to $4e^{5x}$, and $4e^{2x} \times e^{3x} - e^{4x} \times e^x$ should be simplified to $3e^{5x}$. Unless specified in the question, expressions do not need to be factorized, nor do factorized expressions need to be expanded, so $x(x+1)$ and $x^2 + x$ are both acceptable.

Please note: intermediate **A** marks do NOT need to be simplified.

9 Calculators

A GDC is required for this paper, but if you see work that suggests a candidate has used any calculator not approved for IB DP examinations (eg CAS enabled devices), please follow the procedures for malpractice.

10. Presentation of candidate work

Crossed out work: If a candidate has drawn a line through work on their examination script, or in some other way crossed out their work, do not award any marks for that work unless an explicit note from the candidate indicates that they would like the work to be marked.

More than one solution: Where a candidate offers two or more different answers to the same question, an examiner should only mark the first response unless the candidate indicates otherwise. If the layout of the responses makes it difficult to judge, examiners should apply appropriate discretion to judge which is “first”.

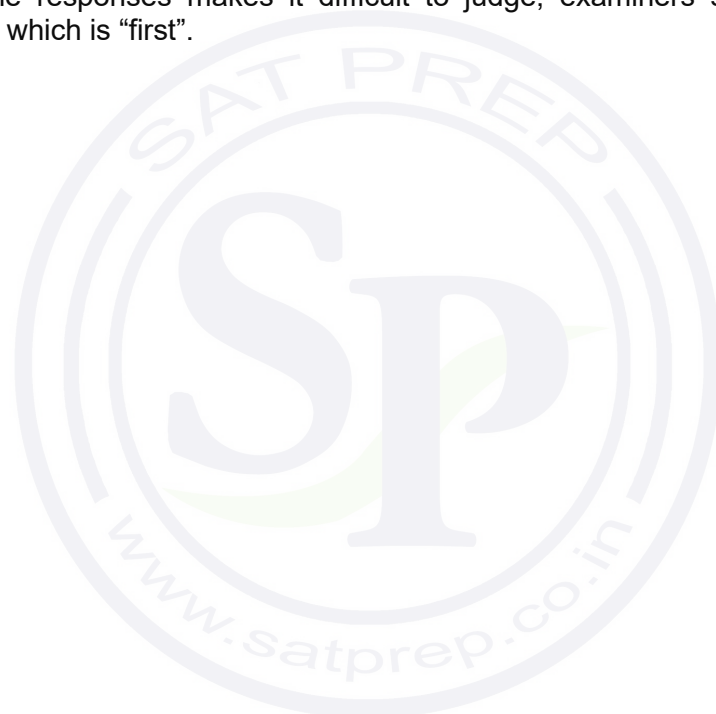

1. (a) attempt to use the cosine rule to find $\hat{C}AB$ (M1)

$$(\hat{C}AB =) \cos^{-1}\left(\frac{42^2 + 35^2 - 36^2}{2 \times 42 \times 35}\right) \quad (A1)$$

$$(\hat{C}AB =) 54.8^\circ (54.8407\dots^\circ) \quad \text{OR} \quad 0.957 (0.957152\dots) \quad A1$$

[3 marks]

(b) (Area =) $\frac{1}{2} \times 42 \times 35 \times \sin 54.8407\dots^\circ$ (A1)

(Area =) 601 (600.903) cm^2 A1

Note: Correct units must be seen for the final **A1** to be awarded.

[2 marks]
[Total 5 marks]

2. (a) 120 (ng) A1

Note: Only accept an exact answer of 120.

[1 mark]

(b) $(m(20000) =) 120e^{-0.000121 \times 20000}$ (A1)
10.7 (10.6705.....) (ng) A1

[2 marks]

- (c) attempt to write or solve an inequality (or equality) with a value of 60 seen (M1)
 $(m(t) =) 120e^{-0.000121t} \leq 60$ **OR** sketch **OR** table of values

$(t >) 5728.489\dots$ (A1)
5729 (years) A1

Note: Do not accept 5728 or 5730 for the final **A1**.

[3 marks]
[Total: 6 marks]

3. (a) recognizing need to find $P(W > 3.5)$ **OR** $1 - P(W < 3.5)$ (M1)
 $(P(W > 3.5) =) 0.994 (0.993790\dots)$ A1

Note: Award **M1A0** for an answer of 0.99 with no working.

[2 marks]

- (b) (i) appropriate use of the GDC to find either a or b seen in either (b)(i) or (b)(ii) (M1)
 $a = 3.99 (3.98737\dots)$ A1
- (ii) $b = 5.01 (5.01262\dots)$ A1

Note: The working for (M1) may be seen and awarded in part (b)(ii) if part (b)(i) has not been answered.

[3 marks]

- (c) multiplying two identical probabilities (M1)
 $P(W < 3.5) \times P(W < 3.5)$ **OR** $(1 - \text{their (a)}) \times (1 - \text{their (a)})$

Note: Accept a lower bound of zero for W , given the context.

$(0.00620967)^2$
 $0.0000386 (0.0000385601\dots \text{OR } 3.86 \times 10^{-5})$ A1

Note: Award **M0A0** for an answer greater than 1 such as 3.86.
 Award **M1A0** for 3.86E-5.

[2 marks]

[Total: 7 marks]

4. (a) recognition that % increase gives the common difference (M1)
 $25000 \times 0.05 = 1250$ A1
 [2 marks]
- (b) $25000 + 1250n > 44000$ **OR** $25000 + 1250(n - 1) > 44000$ (accept equality) (A1)
 attempt to solve their inequality **OR** equality (sketch **OR** cross-over values
OR algebraic manipulation) (M1)
 $k = 16$ A1

Note: Award **(A1)(M1)A0** for 15.2, 16.2 or 17 seen.

[3 marks]

[Total: 5 marks]

5. (a)

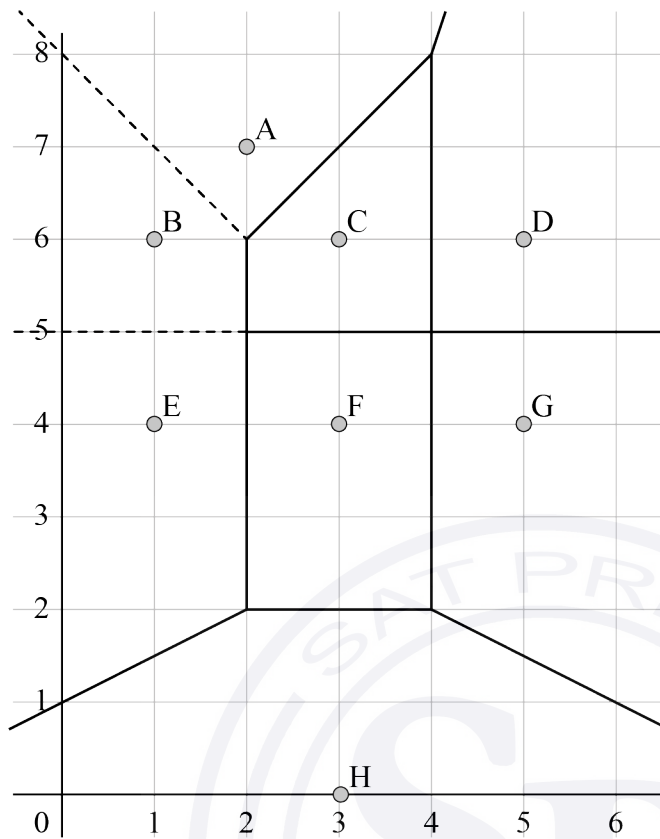

A1A1

Note: Award at most **A1A0** if lines are not straight OR not accurate through the midpoint of AB and (0, 8) and through the midpoint of BE and (0, 5).

[2 marks]

(b) (i) area of $F = 6$ OR area of $C = 4$
($6 \times 4 =$) $24 \text{ (km}^2\text{)}$

(A1)

A1

(ii) ($4 \times 4 =$) $16 \text{ (km}^2\text{)}$

A1

[3 marks]

(c) The population in each cell might be equal

R1

[1 mark]

[Total 6 marks]

6. (a) (i) $a=30$ A1
(ii) $p=11$ A1
[2 marks]

(b) **EITHER**
substituting $n = 11$ and equating to 230 (or equivalent) (M1)
 $30(11) + b = 230$

OR
using an arithmetic sequence (M1)
 $200 + 30(n - 10)$

THEN
 $b = -100$ A1
[2 marks]
[Total 4 marks]

7. (a) $N = 60, I = 4.5, PV = +400\,000, PMT = -3600, P/Y = 12, C/Y = 12$ (M1)(A1)

Note: Award **M1** for use of Finance solver with any 2 entries correct, Award **A1** for all correct.

$FV = \$259\,000(\$258\,994)$ A1
[3 marks]

- (b) $I = 4.5, PV = +400\,000, PMT = -3600, FV = 0, P/Y = 12, C/Y = 12$ (A1)(A1)

Note: Award **A1** for $FV = 0$, award **A1** for all correct.

$N = 144$ A1
[3 marks]
[Total 6 marks]

8. (a) $d = \frac{16.63 + 7.83}{2}$ (A1)
 ($d =$) 12.2 (12.23) A1
 [2 marks]
- (b) ($a =$) 4.4 A1
 [1 mark]
- (c) period = $2(356 - 173)$ (= 366) (A1)
 $(b =) \frac{2\pi}{366} = \frac{\pi}{183}$ (= 0.0171671...) (Accept $b = \frac{360}{366}$ (= 0.983606...)) A1
 [2 marks]
- (d) **EITHER**
 attempt to find midpoint of x values of max and min (M1)
 $c = \frac{-10 + 173}{2}$
- OR**
 substitute values and solve (M1)
 $b(173 - c) = \frac{\pi}{2}$ **OR** $16.63 = 4.4 \sin(b(173 - c)) + 12.23$
- THEN**
 ($c =$) 81.5 A1

Note: Accept other possible positive values of $c = 81.5 + 366n$.
 FT from their "c" consistent with their "a".

[2 marks]
 [Total 7 marks]

9. (a)

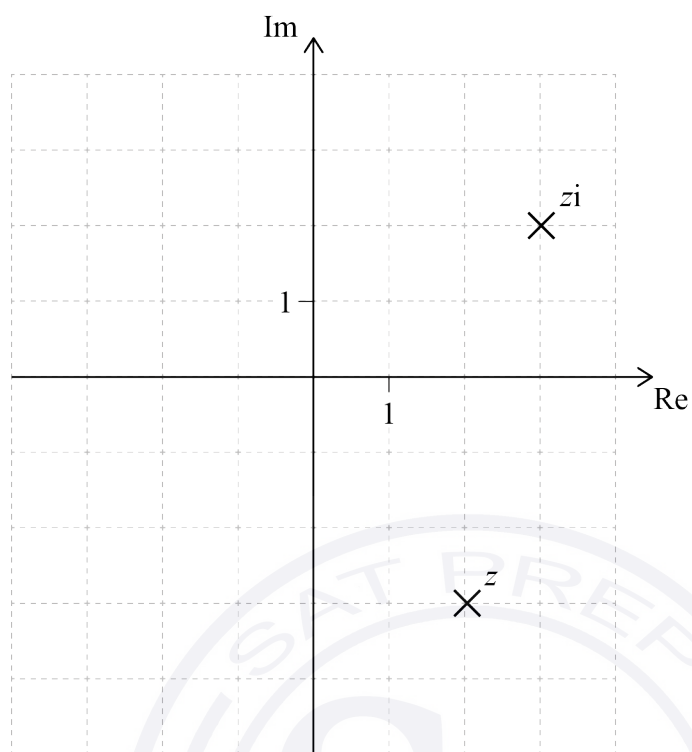

A1
[1 mark]

(b) (i) 3.61 (3.60555..., $\sqrt{13}$)

A1

(ii) -0.983 (-0.982793...)

A1
[2 marks]

(c) $3 + 2i$

A1
[1 mark]

(d) **EITHER**

rotation, (anticlockwise) $\frac{\pi}{2}$ (or 90°) (about the origin)

A1

OR

translation $\begin{pmatrix} 1 \\ 5 \end{pmatrix}$

A1

[1 mark]
[Total 5 marks]

10. (a) vertical stretch scale factor 4

A1

Note: The vertical stretch can occur in any order.

EITHER

translation $\begin{pmatrix} 3 \\ 0 \end{pmatrix}$ followed by horizontal stretch scale factor $\frac{1}{2}$

A1A1

OR

horizontal stretch scale factor $\frac{1}{2}$ followed by translation $\begin{pmatrix} 1.5 \\ 0 \end{pmatrix}$

A1A1

Note: Award **A1A0** in either approach, for correct transformations, but incorrect order.

[3 marks]

(b) $g(2) = 5$

(A1)

$f(5) = 7.78$ ($= 7.78364\dots, 4\ln 7$)

A1

[2 marks]

(c) $4\ln(2g(x) - 3) = 2\ln 9$

(M1)

$g(x) = 3$

(A1)

$x = 1$

A1

[3 marks]

[Total 8 marks]

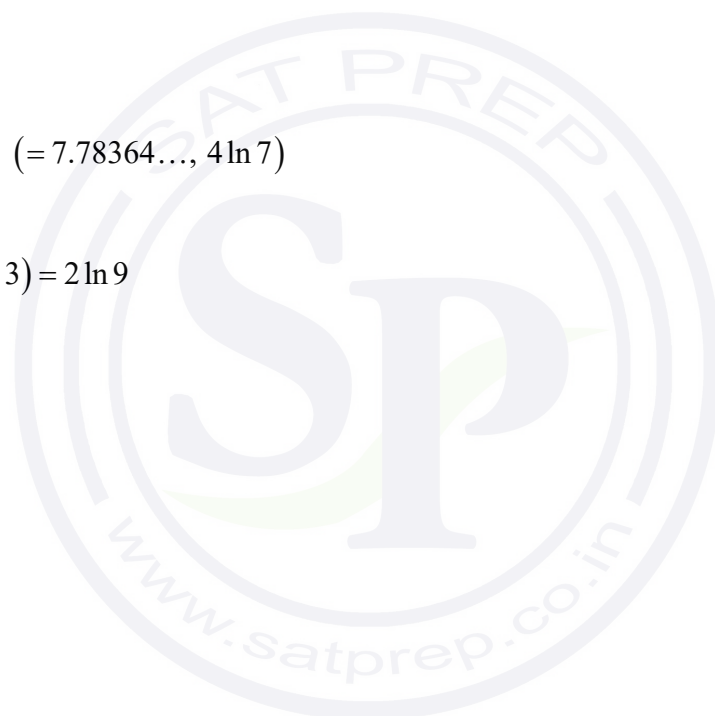

11. (a) attempt to find $|M - \lambda I|$ (M1)
 $(-4 - \lambda)(3 - \lambda) + 6 (= 0)$ (A1)
 $2, -3$ A1
[3 marks]

(b) (i) $\begin{pmatrix} 2 & 0 \\ 0 & -3 \end{pmatrix}$ OR $\begin{pmatrix} -3 & 0 \\ 0 & 2 \end{pmatrix}$ A1

(ii) EITHER

attempt to solve $M \begin{pmatrix} x \\ y \end{pmatrix} = 2 \begin{pmatrix} x \\ y \end{pmatrix}$ OR $M \begin{pmatrix} x \\ y \end{pmatrix} = -3 \begin{pmatrix} x \\ y \end{pmatrix}$ (M1)

OR

attempt to use $(M - \lambda I) \begin{pmatrix} x \\ y \end{pmatrix} = \begin{pmatrix} 0 \\ 0 \end{pmatrix}$ (M1)

THEN

$\begin{pmatrix} 1 \\ 3 \end{pmatrix}$ and $\begin{pmatrix} 2 \\ 1 \end{pmatrix}$ (or any multiple) (A1)(A1)

$P = \begin{pmatrix} 1 & 2 \\ 3 & 1 \end{pmatrix}$ OR $P = \begin{pmatrix} 2 & 1 \\ 1 & 3 \end{pmatrix}$ A1

Note: Award **A1** for correct eigenvectors in a matrix in the correct position for their **D**.

[5 marks]
[Total 8 marks]

12. (a)

Bounce number, n	Maximum height, h , according to the model
1	0.613
2	0.514
3	0.431 (0.430988...)
4	0.361 (0.361383...)

A1A1
[2 marks]

(b) $(0.430988... - 0.439)^2 + (0.361383... - 0.377)^2$ seen
 3.08×10^{-4} ($3.08055... \times 10^{-4}$)

(A1)

A1

[2 marks]

(c) (i) $h = 0.716 \times 0.851^n$ (0.715766..., 0.850774...)

A2

Note: Award **A2** for $h = 0.716e^{-0.162n}$ ($h = 0.715766...e^{-0.161608...n}$)

Award at most **A1A0** for correct coefficients, with any error in notation (e.g. x instead of n , missing $h=$)

Award at most **A1A0** for $h = 0.731 \times 0.838^n$ from using the values from the model.

(ii) ($h=$) 0.716 (metres)

A1

[3 marks]

[Total 7 marks]

13. attempt to substitute $t = 9$ and $P = 433$ (OR $t = 12$ and $P = 954$) (M1)

$$433 = \frac{L}{1 + Ce^{-0.28(9)}} \quad \text{and} \quad 954 = \frac{L}{1 + Ce^{-0.28(12)}} \quad \text{(A1)(A1)}$$

attempt to rearrange into linear form or substitute for L

$$433(1 + Ce^{-0.28(9)}) = L \quad \text{and} \quad 954(1 + Ce^{-0.28(12)}) = L \quad \text{OR} \quad 954 = \frac{433(1 + Ce^{-0.28(9)})}{1 + Ce^{-0.28(12)}} \quad \text{(M1)}$$

attempt to solve simultaneously (e.g. graph or eliminate L) (M1)
 $C = 306.187\dots$

$$L = 11100 \quad (11100.2\dots) \quad \text{A1}$$

Note: Accept a correct decimal value.

[6 marks]

14. (a) attempt to solve $f(x) = 0.25$ (M1)
 0.302 (0.301928...) (A1)

[2 marks]

- (b) evidence of using chain rule (multiple of $-4x$ seen with $e^{\text{(something)}}$) (M1)
 $f'(x) = -1.2xe^{-2x^2}$ (A1)

[2 marks]

- (c) $f'(0.302) = -0.302$ (-0.301928...) (A1)
 finding the negative reciprocal of their gradient (M1)
 gradient of normal = $\frac{-1}{-0.302}$ (= 3.31) (3.312104...)

recognition that gradient equals \tan OR finding the x -intercept of the flagpole and using right-angled triangle to find $\tan \theta$. (M1)

$$\theta = \arctan(3.31)$$

$$= 1.28 \quad (1.27757\dots) \text{ radians } (=73.2^\circ) \quad (73.1994\dots^\circ)$$

A1

[4 marks]

[Total 8 marks]

15. (a) normal distribution A1
 Mean = 15 (cm) A1
 Standard deviation = 0.4 (cm) **OR** variance = 0.16 (cm²) A1
[3 marks]
- (b) $E(W) = 3$ (A1)
 $\text{Var}(W) = 0.4^2 + 0.25^2$ (A1)
 $= 0.223$ (0.2225) (A1)
 W is normally distributed (M1)
 $(P(W < 2.5) =) 0.145$ (0.144572...) A1

Note: Accept $P(0 < W < 2.5)$.

[5 marks]
[Total 8 marks]

16. (a) 0.781 (0.781124...) (accept $4 - 2\ln(5)$) A1
[1 mark]
- (b) recognizing need to find $\pi \int x^2 dy$ (M1)
 $\pi \int_{0.781}^{11.8} x^2 dy$ (A1)

Note: Award **A1** for correct limits and squaring **their** x , seen anywhere.

- attempt to make x the subject. (M1)
 $2\ln(5 - x) = 4 - y$
- attempt to remove \ln by using exponent base e . (M1)
 $5 - x = e^{\frac{4-y}{2}}$
 $x = 5 - e^{\frac{4-y}{2}}$ (A1)
- $(V =) 631$ (cm³) (631.071...) A1

[6 marks]
[Total 7 marks]

17. (a) substituting h and f_1 into formula for x_{n+1} **OR** h and f_2 into y_{n+1} **(M1)**

Note: **M1** may be awarded for an appropriate table with at least one correct value for F or L , even if there is no evidence of substitution into the Euler equations.

$$F_{n+1} = F_n + 4(0.000004F_nL_n - 0.2F_n) \quad \text{AND} \quad L_{n+1} = L_n + 4(0.06L_n - 0.00003F_nL_n) \quad \text{(A1)}$$

evidence of correct use of Euler's method **(A1)**

Note: Award **A1** for any correct value of F_{n+1} AND L_{n+1} for $t = 4, 8, \dots$ seen (including this intermediate value presented as a final answer).

t	F	L
0	5000	80000
4	7400	51200
8	7542	18022
12	3683	6037
16	1092	4817
20	303	5342

- (i) maximum value of $F = 7542$ (at $t = 8$) **A1**
- (ii) minimum value of $L = 4817$ (at $t = 16$) **A1**
- [5 marks]**
- (b) (i) they die out (population becomes zero) **A1**
- (ii) Any valid reason **R1**
 E.g. Euler's method is only an approximation
 Other factors might change the model over time

[2 marks]
[Total 7 marks]

Markscheme

May 2024

**Mathematics:
Applications and interpretation**

Higher level

Paper 1

© International Baccalaureate Organization 2024

All rights reserved. No part of this product may be reproduced in any form or by any electronic or mechanical means, including information storage and retrieval systems, without the prior written permission from the IB. Additionally, the license tied with this product prohibits use of any selected files or extracts from this product. Use by third parties, including but not limited to publishers, private teachers, tutoring or study services, preparatory schools, vendors operating curriculum mapping services or teacher resource digital platforms and app developers, whether fee-covered or not, is prohibited and is a criminal offense.

More information on how to request written permission in the form of a license can be obtained from <https://ibo.org/become-an-ib-school/ib-publishing/licensing/applying-for-a-license/>.

© Organisation du Baccalauréat International 2024

Tous droits réservés. Aucune partie de ce produit ne peut être reproduite sous quelque forme ni par quelque moyen que ce soit, électronique ou mécanique, y compris des systèmes de stockage et de récupération d'informations, sans l'autorisation écrite préalable de l'IB. De plus, la licence associée à ce produit interdit toute utilisation de tout fichier ou extrait sélectionné dans ce produit. L'utilisation par des tiers, y compris, sans toutefois s'y limiter, des éditeurs, des professeurs particuliers, des services de tutorat ou d'aide aux études, des établissements de préparation à l'enseignement supérieur, des fournisseurs de services de planification des programmes d'études, des gestionnaires de plateformes pédagogiques en ligne, et des développeurs d'applications, moyennant paiement ou non, est interdite et constitue une infraction pénale.

Pour plus d'informations sur la procédure à suivre pour obtenir une autorisation écrite sous la forme d'une licence, rendez-vous à l'adresse <https://ibo.org/become-an-ib-school/ib-publishing/licensing/applying-for-a-license/>.

© Organización del Bachillerato Internacional, 2024

Todos los derechos reservados. No se podrá reproducir ninguna parte de este producto de ninguna forma ni por ningún medio electrónico o mecánico, incluidos los sistemas de almacenamiento y recuperación de información, sin la previa autorización por escrito del IB. Además, la licencia vinculada a este producto prohíbe el uso de todo archivo o fragmento seleccionado de este producto. El uso por parte de terceros —lo que incluye, a título enunciativo, editoriales, profesores particulares, servicios de apoyo académico o ayuda para el estudio, colegios preparatorios, desarrolladores de aplicaciones y entidades que presten servicios de planificación curricular u ofrezcan recursos para docentes mediante plataformas digitales—, ya sea incluido en tasas o no, está prohibido y constituye un delito.

En este enlace encontrará más información sobre cómo solicitar una autorización por escrito en forma de licencia: <https://ibo.org/become-an-ib-school/ib-publishing/licensing/applying-for-a-license/>.

Instructions to Examiners

Abbreviations

- M** Marks awarded for attempting to use a correct **Method**.
- A** Marks awarded for an **Answer** or for **Accuracy**; often dependent on preceding **M** marks.
- R** Marks awarded for clear **Reasoning**.
- AG** Answer given in the question and so no marks are awarded.
- FT** Follow through. The practice of awarding marks, despite candidate errors in previous parts, for their correct methods/answers using incorrect results.

Using the markscheme

1 General

Award marks using the annotations as noted in the markscheme eg **M1**, **A2**.

2 Method and Answer/Accuracy marks

- Do **not** automatically award full marks for a correct answer; all working **must** be checked, and marks awarded according to the markscheme.
- It is generally not possible to award **M0** followed by **A1**, as **A** mark(s) depend on the preceding **M** mark(s), if any.
- Where **M** and **A** marks are noted on the same line, e.g. **M1A1**, this usually means **M1** for an **attempt** to use an appropriate method (e.g. substitution into a formula) and **A1** for using the **correct** values.
- Where there are two or more **A** marks on the same line, they may be awarded independently; so if the first value is incorrect, but the next two are correct, award **A0A1A1**.
- Where the markscheme specifies **A3**, **M2** etc., do **not** split the marks, unless there is a note.
- The response to a “show that” question does not need to restate the **AG** line, unless a **Note** makes this explicit in the markscheme.
- Once a correct answer to a question or part question is seen, ignore further working even if this working is incorrect and/or suggests a misunderstanding of the question. This will encourage a uniform approach to marking, with less examiner discretion. Although some candidates may be advantaged for that specific question item, it is likely that these candidates will lose marks elsewhere too.
- An exception to the previous rule is when an incorrect answer from further working is used **in a subsequent part**. For example, when a correct exact value is followed by an incorrect decimal approximation in the first part and this approximation is then used in the second part. In this situation, award **FT** marks as appropriate but do not award the final **A1** in the first part. Examples:

	Correct answer seen	Further working seen	Any FT issues?	Action
1.	$8\sqrt{2}$	5.65685... (incorrect decimal value)	No. Last part in question.	Award A1 for the final mark (condone the incorrect further working)
2.	$\frac{35}{72}$	0.468111... (incorrect decimal value)	Yes. Value is used in subsequent parts.	Award A0 for the final mark (and full FT is available in subsequent parts)

3 Implied marks

Implied marks appear in **brackets e.g. (M1)**, and can only be awarded if **correct** work is seen or implied by subsequent working/answer.

4 Follow through marks (only applied after an error is made)

Follow through (**FT**) marks are awarded where an incorrect answer from one **part** of a question is used correctly in **subsequent** part(s) (e.g. incorrect value from part (a) used in part (d) or incorrect value from part (c)(i) used in part (c)(ii)). Usually, to award **FT** marks, **there must be working present** and not just a final answer based on an incorrect answer to a previous part. However, if all the marks awarded in a subsequent part are for the answer or are implied, then **FT** marks should be awarded for *their* correct answer, even when working is not present.

For example: following an incorrect answer to part (a) that is used in subsequent parts, where the markscheme for the subsequent part is **(M1)A1**, it is possible to award full marks for *their* correct answer, **without working being seen**. For longer questions where all but the answer marks are implied this rule applies but may be overwritten by a **Note** in the Markscheme.

- Within a question part, once an **error** is made, no further **A** marks can be awarded for work which uses the error, but **M** marks may be awarded if appropriate.
- If the question becomes much simpler because of an error then use discretion to award fewer **FT** marks, by reflecting on what each mark is for and how that maps to the simplified version.
- If the error leads to an inappropriate value (e.g. probability greater than 1, $\sin \theta = 1.5$, non-integer value where integer required), do not award the mark(s) for the final answer(s).
- The markscheme may use the word “their” in a description, to indicate that candidates may be using an incorrect value.
- If the candidate’s answer to the initial question clearly contradicts information given in the question, it is not appropriate to award any **FT** marks in the subsequent parts. This includes when candidates fail to complete a “show that” question correctly, and then in subsequent parts use their incorrect answer rather than the given value.
- Exceptions to these **FT** rules will be explicitly noted on the markscheme.
- If a candidate makes an error in one part but gets the correct answer(s) to subsequent part(s), award marks as appropriate, unless the command term was “Hence”.

5 Mis-read

If a candidate incorrectly copies values or information from the question, this is a mis-read (**MR**). A candidate should be penalized only once for a particular misread. Use the **MR** stamp to indicate that this has been a misread and do not award the first mark, even if this is an **M** mark, but award all others as appropriate.

- If the question becomes much simpler because of the **MR**, then use discretion to award fewer marks.
- If the **MR** leads to an inappropriate value (e.g. probability greater than 1, $\sin \theta = 1.5$, non-integer value where integer required), do not award the mark(s) for the final answer(s).
- Miscopying of candidates' own work does **not** constitute a misread, it is an error.
- If a candidate uses a correct answer, to a "show that" question, to a higher degree of accuracy than given in the question, this is NOT a misread and full marks may be scored in the subsequent part.
- **MR** can only be applied when work is seen. For calculator questions with no working and incorrect answers, examiners should **not** infer that values were read incorrectly.

6 Alternative methods

Candidates will sometimes use methods other than those in the markscheme. Unless the question specifies a method, other correct methods should be marked in line with the markscheme. If the command term is 'Hence' and not 'Hence or otherwise' then alternative methods are not permitted unless covered by a note in the mark scheme.

- Alternative methods for complete questions are indicated by **METHOD 1**, **METHOD 2**, etc.
- Alternative solutions for parts of questions are indicated by **EITHER . . . OR**.

7 Alternative forms

Unless the question specifies otherwise, **accept** equivalent forms.

- As this is an international examination, accept all alternative forms of **notation** for example 1.9 and 1,9 or 1000 and 1,000 and 1.000.
- Do not accept final answers written using calculator notation. However, **M** marks and intermediate **A** marks can be scored, when presented using calculator notation, provided the evidence clearly reflects the demand of the mark.
- In the markscheme, equivalent **numerical** and **algebraic** forms will generally be written in brackets immediately following the answer.
- In the markscheme, some **equivalent** answers will generally appear in brackets. Not all equivalent notations/answers/methods will be presented in the markscheme and examiners are asked to apply appropriate discretion to judge if the candidate work is equivalent.

8 Format and accuracy of answers

If the level of accuracy is specified in the question, a mark will be linked to giving the answer to the required accuracy. If the level of accuracy is not stated in the question, the general rule applies to final answers: *unless otherwise stated in the question all numerical answers must be given exactly or correct to three significant figures.*

Where values are used in subsequent parts, the markscheme will generally use the exact value, however candidates may also use the correct answer to a “correct” level of accuracy (e.g 3 sf) in subsequent parts. The markscheme will often explicitly include the subsequent values that come “from the use of 3 sf values”.

Simplification of final answers: Candidates are advised to give final answers using good mathematical form. In general, for an **A** mark to be awarded, arithmetic should be completed, and any values that lead to integers should be simplified; for example, $\sqrt{\frac{25}{4}}$ should be written as $\frac{5}{2}$.

An exception to this is simplifying fractions, where lowest form is not required (although the numerator and the denominator must be integers); for example, $\frac{10}{4}$ may be left in this form or written as $\frac{5}{2}$. However, $\frac{10}{5}$ should be written as 2, as it simplifies to an integer.

Algebraic expressions should be simplified by completing any operations such as addition and multiplication, e.g. $4e^{2x} \times e^{3x}$ should be simplified to $4e^{5x}$, and $4e^{2x} \times e^{3x} - e^{4x} \times e^x$ should be simplified to $3e^{5x}$. Unless specified in the question, expressions do not need to be factorized, nor do factorized expressions need to be expanded, so $x(x+1)$ and $x^2 + x$ are both acceptable.

Please note: intermediate **A** marks do NOT need to be simplified.

9 Calculators

A GDC is required for this paper, but If you see work that suggests a candidate has used any calculator not approved for IB DP examinations (eg CAS enabled devices), please follow the procedures for malpractice.

10. Presentation of candidate work

Crossed out work: If a candidate has drawn a line through work on their examination script, or in some other way crossed out their work, do not award any marks for that work unless an explicit note from the candidate indicates that they would like the work to be marked.

More than one solution: Where a candidate offers two or more different answers to the same question, an examiner should only mark the first response unless the candidate indicates otherwise. If the layout of the responses makes it difficult to judge, examiners should apply appropriate discretion to judge which is “first”.

1. (a) **EITHER**

$$N = 96$$

$$PV = \mp 100000$$

$$FV = \pm 150000$$

$$P/Y = 12$$

$$C/Y = 12$$

(M1)(A1)

OR

$$N = 8$$

$$PV = \mp 100000$$

$$FV = \pm 150000$$

$$P/Y = 1$$

$$C/Y = 12$$

(M1)(A1)

OR

$$150000 = 100000 \left(1 + \frac{I}{100 \times 12} \right)^{12 \times 8}$$

(M1)(A1)

Note: Award **M1** for an attempt to use a financial app (at least 3 entries, not necessarily correct) or an attempt to use a compound interest formula.
Award **A1** for all entries correct in financial app or correct substitution in compound interest formula.

THEN

$$I = 5.08 \text{ (5.07903...)}$$

A1

[3 marks]

(b) $N = 120$

$$I\% = 6.1$$

$$PV = \mp 150000$$

$$PMT = \pm 1000$$

$$P/Y = 12$$

$$C/Y = 12$$

(M1)(A1)

Note: Award **M1** for an attempt to use a financial app (at least 3 entries, not necessarily correct). Award **A1** for all entries correct in financial app (condone missing +/- sign if the correct final answer is seen).

$$FV = (\$) 110867$$

A1

Note: Answer must be correct to nearest dollar to award the final **A1**. Award **(M1)(A1)A0** for an unsupported final answer to a greater degree of accuracy eg. (\$) 110866.70...
Award **M1A1A0** for a truncated answer of 110866 if no working is shown.

[3 marks]

[Total: 6 marks]

2. (a) (i) $r = 0.995$ (0.994705...) A2

Note: Award **A1** for 0.99.

- (ii) $m = 10.6t + 43.9$ (10.6032... t + 43.8780...) A1A1

Note: Second **A1** is for the correct variables.

[4 marks]

- (b) **EITHER**
 $10.6032... \times 1.5$ (M1)

OR
 $(10.6032...(t + 1.5) + 43.8780...) - (10.6032...(t) + 43.8780...)$ (M1)

THEN
 15.9 (marks) (15.9048...) A1

Note: Accept 16.

[2 marks]

- (c) *Accept any valid reason* R1

e.g:

The students in the sample might not be of equal ability / she has not controlled for ability

She might have originally obtained close to full marks so an extra 15.9 would not be possible.

[1 mark]

[Total: 7 marks]

3. (a) (i) attempt to rearrange to isolate C (M1)
 e.g., subtracting 32 or dividing the equation by 1.8

$$C = \frac{5}{9}(F - 32) \left(C = \frac{F - 32}{1.8}, C = 0.556F - 17.8 \right) \quad \text{A1}$$

Note: If the answer is not written as an equation, award at most **M1A0**.

(ii) $C = \left(\frac{77 - 32}{1.8} \right) 25$ (°C) A1

[3 marks]

- (b) (i) $(1.8 \times 17 + 32 =)$ 62.6 (°F) A1

(ii) recognizing that the "+32" does not affect the SD
 $(1.8 \times 9 =)$ 16.2 (°F) (M1)
A1

Note: Award **M0A0** for $1.8 \times 9 + 32$ (= 48.2).

[3 marks]

[Total 6 marks]

4. attempt to use Euler

$$y_{n+1} = y_n + 0.1 \log(x_n + y_n) \quad (\mathbf{A1})$$

$$y_1 (= 1 + 0.1 \times \log_{10}(1)) = 1 \quad (\mathbf{A1})$$

$$y_2 = 1.004139... \quad (\mathbf{A1})$$

THEN

when $x = 2$ $y(2) \approx 1.61$ (1.60536...) **A1**

[Total: 4 marks]

5. (a) $y = 0.5x - 1$ **A1A1**

Note: Award **A1** for $0.5x$ and **A1** for -1 (or equivalent equation). Award at most **A1A0** if answer is not presented as an equation.

[2 marks]

(b) $(6.857, 2.429)$ **A1A1**

Note: If both answers are not correct to 4 sig figs, award at most **A1A0**.

Accept $x = 6.857$, $y = 2.429$.

Award **A1A0** for $\left(\frac{48}{7}, \frac{17}{7}\right)$. Award **A0A1** for $(2.429, 6.857)$.

[2 marks]

(c)

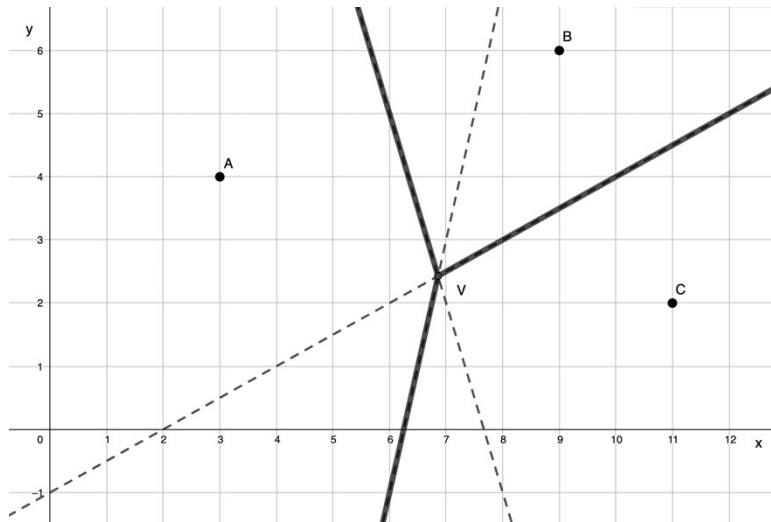

A2

Note: Award marks as shown in the table below. Condone edges that do not extend to the sides of the graph or beyond the x -axis.

Correct edges	Incorrect edges	Marks
3	0	A2
3	1	A1A0
3	2 or more	A0A0
2	0	A1A0
2	1	A1A0
2	2 or more	A0A0
1	0	A1A0
1	1 or more	A0A0

[2 marks]
[Total 6 marks]

6. (a) attempt to substitute into geometric sequence formula for twelfth term **OR**
 at least three correct terms of the sequence **(M1)**
 $u_{12} = 40 \times 1.1^{12-1}$ **OR** 40, 44, 48.4, ...
 114 (114.124...) **A1**

[2 marks]

- (b) (i) attempt to substitute into geometric series formula **OR**
 a sum of at least the first three terms **(M1)**
 $S_{12} = \frac{40(1.1^{12} - 1)}{1.1 - 1}$ **OR** $\sum_1^{12} (40 \times 1.1^{n-1})$ **OR** 40 + 44 + 48.4 + ...

Note: Award **M1** for $u_1 = 40$ and $r = 1.1$ seen as part of a geometric series formula, or **M1** for sigma notation and their u_n formula (condone missing limits), or **M1** for the sum of at least the **correct** first three terms of the sequence.

$S_{12} = 855$ (855.371...) **A1**

- (ii) finding $S_{24} = 3539.89...$ or attempt to find the sum between u_{13} and u_{24} **(M1)**

Note: Award **M1** for $S_{24} = 3539.89...$ or sigma notation that includes correct limits and their u_n formula or a substituted geometric series formula that includes 125.537... and $n = 12$ or a list of terms that includes at least the 13th term and the 24th term.

$3539.89... - 855.371...$ **OR** $\sum_{13}^{24} (40 \times 1.1^{n-1})$ **OR**
 $(S_{13 \text{ to } 24} =) \frac{125.537... (1.1^{12} - 1)}{1.1 - 1}$ **OR** 125.537 + ... + 358.172... **(A1)**

Note: Accept a calculation using $u_{13} = 125$ or 126.

2680 (2684.52..., 2684, 2685) **A1**

Note: For $u_{13} = 125$, the sum is 2673.03... and for $u_{13} = 126$, the sum is 2694.41...

[5 marks]
[Total: 7 marks]

7. (a) (i) $m = ah^3$ (M1)
 $64 = a \times 0.8^3 \Rightarrow a = 125$ (A1)

$m = 125h^3$ A1

Note: The final answer must be written as m in terms of h to award the final A1.

(ii) $m = (125(0.75)^3) = 52.7 \text{ (kg) (52.7343...)}$ A1

[4 marks]

(b) **EITHER (finding the height of the lion)**

$(220 = 125h^3)$
 $h = \sqrt[3]{1.76} \text{ (1.20736...)}$ (A1)

$E = k_1h^2$ (seen anywhere) (A1)

$k = \frac{(\sqrt[3]{1.76})^2}{0.8^2}$ (M1)

$= 2.28 \text{ (2.27769...)}$ A1

OR (finding a formula for E in terms of m)

$(m = 125h^3)$
 $E = k_1h^2$ (A1)

$E = k_2m^{\frac{2}{3}}$ (A1)

$k = \frac{220^{\frac{2}{3}}}{64^{\frac{2}{3}}}$ (M1)

$= 2.28 \text{ (2.27769...)}$ A1

[4 marks]

[Total 8 marks]

8. (a) B and C A1
[1 mark]

(b) correct intervals seen ($x \leq 5$ (or $x < 5$) AND $x \geq 5$ (or $x > 5$)) A1

Note: The case of $x = 5$ must be included for this **A1** to be awarded.

attempt to add edges to $33+x$ (M1)

(If $x < 5$ (or $x \leq 5$) then repeat BC and) length is $33+2x$ A1

(If $x > 5$ (or $x \geq 5$) then repeat AB and AC and) length is $(33+x+5)=38+x$ A1

Note: If the intervals are not explicit, award at most **A0(M1)A1A1**.

[4 marks]
[Total 5 marks]

9. (a) attempt to integrate by substitution or inspection (M1)
 $4 \ln|2x+3|+c$ OR $4 \ln|x+1.5|+c$ A1A1

Note: Award **M1** for $\ln(2x+3)$ or $\ln(x+1.5)$, **A1** for the 4 and **A1** for c . The **A** marks can only be awarded if the **M** mark is awarded. Condone absence of modulus signs.

[3 marks]

(b) recognizing that area is $[4 \ln(2x+3)]_0^6$ (M1)

$= 4 \ln(15) - 4 \ln(3)$ (A1)

use of log laws for their expression (M1)

$= 4 \ln(5) (= 2 \ln(25) = 1 \ln(625))$ A1

Note: Award **(M1)A0M0A0** for an unsupported final answer of 6.43775...
 Award at most **(M1)A1FTM0A0** if their answer from part (a) does not include \ln .

[4 marks]
[Total 7 marks]

10. (recognition that OB is a radius)

$$(\text{radius} =) \sqrt{5^2 + 8^2} (= \sqrt{89})$$

(A1)

EITHER (finding angle BOQ)

correct calculation for finding $\hat{B}OA$

(A1)

$$\hat{B}OA = \arctan\left(\frac{8}{5}\right) \quad \text{OR} \quad \tan \hat{B}OA = \frac{8}{5}$$

expressing $\hat{B}OQ$ as $90 + \hat{B}OA$

(M1)

$$\hat{B}OQ = 90 + \arctan\left(\frac{8}{5}\right) \quad \text{OR} \quad \hat{B}OQ = \frac{\pi}{2} + \arctan\left(\frac{8}{5}\right)$$

$$(\hat{B}OQ =) 147.994^\circ \dots \quad \text{OR} \quad 2.58299 \dots$$

substituting *their* radius and angle BOQ correctly into arc length formula

(M1)

$$(\text{arc BQ} =) \frac{90 + \arctan\left(\frac{8}{5}\right)}{360} \times 2\pi(\sqrt{5^2 + 8^2}) \quad \text{OR} \quad \left(\frac{\pi}{2} + \arctan\left(\frac{8}{5}\right)\right) \times (\sqrt{5^2 + 8^2})$$

$$24.4 \text{ (m)} \quad (24.3679 \dots)$$

A1

OR (finding angle BOP)

correct calculation for finding angle $\hat{B}OP$

(A1)

$$\hat{B}OP = \arctan\left(\frac{5}{8}\right) \quad \text{OR} \quad \tan \hat{B}OP = \frac{5}{8}$$

substituting *their* radius and $\hat{B}OP$ correctly into arc length formula

(M1)

$$(\text{arc BP} =) \frac{\arctan\left(\frac{5}{8}\right)}{360} \times 2\pi(\sqrt{5^2 + 8^2})$$

subtracting *their* arc BP from arc PQ

(M1)

$$(\text{arc BQ} =) \pi\sqrt{5^2 + 8^2} - \frac{\arctan\left(\frac{5}{8}\right)}{360} \times 2\pi(\sqrt{5^2 + 8^2})$$

$$24.4 \text{ (m)} \quad (24.3679 \dots)$$

A1

[Total: 5 marks]

11. (a) $\begin{pmatrix} \cos 2\alpha & -\sin 2\alpha \\ \sin 2\alpha & \cos 2\alpha \end{pmatrix}$ **A1A1**

Note: Award **A1** for selecting the correct matrix, **A1** for substituting 2α into a rotation matrix
Award **A1A0** for clockwise rotation. These marks can be awarded independently.
Condone the use of a different symbol.

[2 marks]

(b) $\begin{pmatrix} \cos \alpha & -\sin \alpha \\ \sin \alpha & \cos \alpha \end{pmatrix} \begin{pmatrix} \cos \alpha & -\sin \alpha \\ \sin \alpha & \cos \alpha \end{pmatrix}$
 $= \begin{pmatrix} \cos^2 \alpha - \sin^2 \alpha & -2 \cos \alpha \sin \alpha \\ 2 \cos \alpha \sin \alpha & \cos^2 \alpha - \sin^2 \alpha \end{pmatrix}$ **M1A1**

Note: Award **M1** for an attempt to multiply matrices, e.g. at least one entry correct.

[2 marks]

(c) (i) (Because matrix multiplication represents the composition of transformations)
 two rotations of α are equivalent to a rotation of 2α **R1**
 so the two matrices are equal (so each of the entries are also equal) **R1**
 $\sin(2\alpha) = 2 \sin(\alpha) \cos(\alpha)$ **AG**

(ii) $\cos 2\alpha = \cos^2 \alpha - \sin^2 \alpha$ **A1**

replacing $\cos^2 \alpha$ with $1 - \sin^2 \alpha$ **M1**

$= 1 - \sin^2 \alpha - \sin^2 \alpha$

$= 1 - 2 \sin^2 \alpha$ **AG**

[4 marks]

[Total 8 marks]

12. (a) $40 = 100 - 100 \times 2^{-t}$ (A1)
 0.737 (hours) (0.736965...) A1
- Note:** Accept 44.2 minutes.
- [2 marks]
- (b) values of P are 50, 75, 87.5, 93.75 (A1)
- $$SS_{res} = (50 - 48)^2 + (75 - 74)^2 + (87.5 - 86)^2 + (93.75 - 91)^2$$
- (M1)(A1)
- $$= 14.8 \text{ (14.8125)}$$
- A1
 [4 marks]
- (c) (i) The sum of the square residuals is smaller so it is a better fit R1
- (ii) Accept a valid argument in favour of model P or against the quadratic model. R1
- e.g. any one of the following:
 quadratic has no asymptote
 quadratic will begin to go down
 quadratic will become negative
 quadratic might not go through (0, 0)
 model P is the manufacturer's model
- [2 marks]
 [Total 8 marks]
13. (a) (i) $(|z_1| = \sqrt{4^2 + 5^2} =) 6.40 \text{ (6.40312..., } \sqrt{41})$ A1
- (ii) $(\arg(z_1) =) 0.896 \left(0.896055..., 51.3401...^\circ, \arctan\left(\frac{5}{4}\right) \right)$ A1
- [2 marks]
- (b) angle in triangle is $2 - 0.896055...$ OR $114.591^\circ - 51.3401...^\circ$ (A1)
 use of area of triangle formula (M1)
- $$\frac{1}{2} \times 6.40312... \times 3 \times \sin(2 - 0.896055...)$$
- (A1)
- $$8.58 \text{ (8.57688...)}$$
- A1
- Note:** Accept methods that use Cartesian form or vector product.
- [4 marks]
 [Total 6 marks]

14. (a) $x_B = 4\sqrt{2(t-3)}$ ($t \geq 3$) **A1A1**

Note: Award **A1** for multiplying by 2 and **A1** for $t-3$. Award **A1A0** for $4\sqrt{2t-3}$.

[2 marks]

(b) equating their x_B to $4\sqrt{t}$ **(M1)**

$$4\sqrt{2(t-3)} = 4\sqrt{t}$$

$$t = 6 \text{ (seconds)}$$

A1

Note: Do not **FT** from part (a) to part (b).

[2 marks]

[Total 4 marks]

15. (a) (i)&(ii)

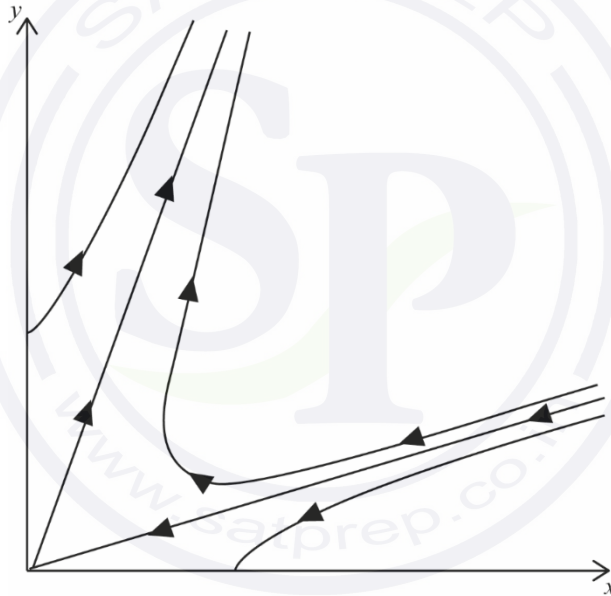

A1A1A1

Note: Award **A1** for correct directions on eigenvectors, **A1** for correct trajectories, **A1** for correct arrows on trajectories.

[3 marks]

(b) for Y not to die out $y > \frac{1}{3}x$ **(R1)**

as $x = 252$, $y > 84$ **(M1)**

(minimum number of new animals is) 25 **A1**

Note: Award **(R1)(M1)A0** for an unsupported 24.

[3 marks]

[Total 6 marks]

16. attempt to find gradient (M1)

EITHER

gradient of tangent = $-\tan 75^\circ$ ($= -3.73205\dots, -2 - \sqrt{3}$) (A1)(A1)

Note: Award **A1** for negative and **A1** for $\tan 75^\circ$ (or equivalent).

OR

gradient of tangent = $\tan 105^\circ$ ($= -3.73205\dots$) (A2)

THEN

$\frac{dy}{dx} = -5.5 \sin(1.1x)$ (A1)

Note: Award **(A1)** for a labelled sketch of the derivative function.

equating derivative to their gradient (M1)

$-5.5 \sin(1.1x) = -3.73205\dots$ **OR** line on graph

$x = 0.677993\dots$ (A1)

Note: Award **(A1)(M1)A0** for an answer of $x = 38.8$, from calculator being in degrees.

Award **A0M1A0** if " $\frac{d}{dx}(5 \cos(1.1x)) = -3.73205\dots$ " seen, but leading to an incorrect x -value.

height = $5 \cos(1.1 \times 0.677993\dots)$ (M1)
 $= 3.67$ (m) (3.67274...) A1

[Total 8 marks]

17. (a) $\begin{pmatrix} 0.25 & 0.25 \\ 0.1 & 0.1 \end{pmatrix} \begin{pmatrix} x \\ y \end{pmatrix} = \begin{pmatrix} 0 \\ 0 \end{pmatrix}$ (M1)

Note: Accept equivalent methods including only using one line of the matrix.

$\begin{pmatrix} 1 \\ -1 \end{pmatrix}$ (or any multiple) A1

[2 marks]

(b) $D^n = \begin{pmatrix} 0.65^n & 0 \\ 0 & 1 \end{pmatrix}$ A1

[1 mark]

(c) $\begin{pmatrix} 1 & 5 \\ -1 & 2 \end{pmatrix} \begin{pmatrix} 0.65^n & 0 \\ 0 & 1 \end{pmatrix} \begin{pmatrix} 1 & 5 \\ -1 & 2 \end{pmatrix}^{-1}$ (M1)

EITHER
multiplying by the initial state (M1)

$\begin{pmatrix} 1 & 5 \\ -1 & 2 \end{pmatrix} \begin{pmatrix} 0.65^n & 0 \\ 0 & 1 \end{pmatrix} \begin{pmatrix} 1 & 5 \\ -1 & 2 \end{pmatrix}^{-1} \begin{pmatrix} 7000 \\ 0 \end{pmatrix}$

$\begin{pmatrix} 1 & 5 \\ -1 & 2 \end{pmatrix} \begin{pmatrix} 0.65^n & 0 \\ 0 & 1 \end{pmatrix} \begin{pmatrix} 2000 \\ 1000 \end{pmatrix}$ (A1)

$\begin{pmatrix} 1 & 5 \\ -1 & 2 \end{pmatrix} \begin{pmatrix} 2000 \times 0.65^n \\ 1000 \end{pmatrix}$ (A1)

$\begin{pmatrix} 2000 \times 0.65^n + 5000 \\ -2000 \times 0.65^n + 2000 \end{pmatrix}$ (A1)

Note: Award **A0** if either term in the matrix is incorrect.

OR

$$\begin{pmatrix} 1 & 5 \\ -1 & 2 \end{pmatrix}^{-1} = \frac{1}{7} \begin{pmatrix} 2 & -5 \\ 1 & 1 \end{pmatrix} \quad \mathbf{A1}$$

$$\begin{pmatrix} 1 & 5 \\ -1 & 2 \end{pmatrix} \begin{pmatrix} 0.65^n & 0 \\ 0 & 1 \end{pmatrix} = \begin{pmatrix} 0.65^n & 5 \\ -0.65^n & 2 \end{pmatrix} \quad \mathbf{A1}$$

Note: The preceding **A1** marks can be awarded independently.

$$\frac{1}{7} \begin{pmatrix} 5 + 2 \times 0.65^n & 5 - 5 \times 0.65^n \\ 2 - 2 \times 0.65^n & 2 + 5 \times 0.65^n \end{pmatrix} \quad \mathbf{A1}$$

Note: Award **A0** if any term in the matrix is incorrect.

multiplying by the initial state **(M1)**

$$\frac{1}{7} \begin{pmatrix} 5 + 2 \times 0.65^n & 5 - 5 \times 0.65^n \\ 2 - 2 \times 0.65^n & 2 + 5 \times 0.65^n \end{pmatrix} \begin{pmatrix} 7000 \\ 0 \end{pmatrix}$$

THEN

$$2000 - 2000 \times 0.65^n \quad (= 2000(1 - 0.65^n)) \quad \mathbf{A1}$$

Note: For the final **A1**, follow through within the question part from the bottom-left entry of their 2x2 matrix or the bottom entry of their 2x1 matrix but only if “in terms of n ”.

If any mistake in the matrices is seen that DOES NOT affect the correct final answer, do not award the penultimate **A1** mark.

[6 marks]
[Total 9 marks]

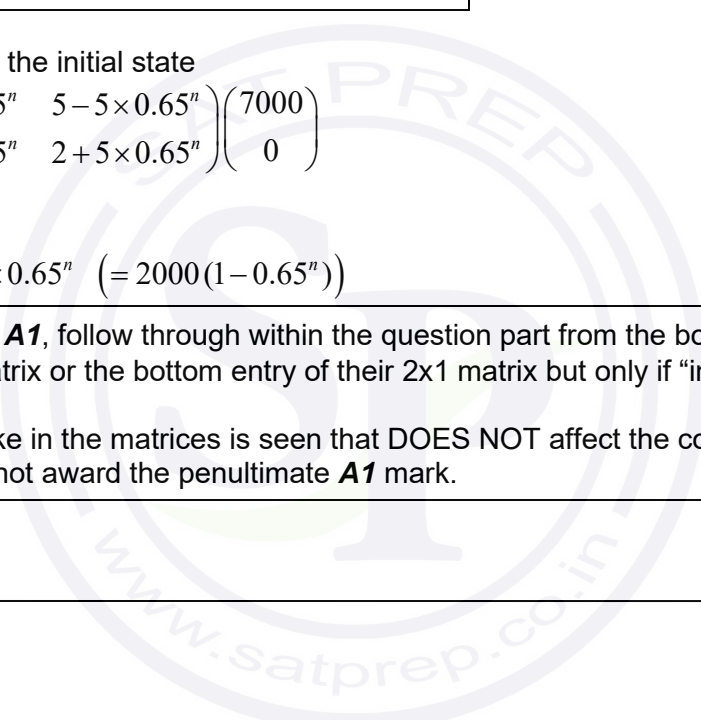

Markscheme

May 2024

**Mathematics:
applications and interpretation**

Higher level

Paper 1

© International Baccalaureate Organization 2024

All rights reserved. No part of this product may be reproduced in any form or by any electronic or mechanical means, including information storage and retrieval systems, without the prior written permission from the IB. Additionally, the license tied with this product prohibits use of any selected files or extracts from this product. Use by third parties, including but not limited to publishers, private teachers, tutoring or study services, preparatory schools, vendors operating curriculum mapping services or teacher resource digital platforms and app developers, whether fee-covered or not, is prohibited and is a criminal offense.

More information on how to request written permission in the form of a license can be obtained from <https://ibo.org/become-an-ib-school/ib-publishing/licensing/applying-for-a-license/>.

© Organisation du Baccalauréat International 2024

Tous droits réservés. Aucune partie de ce produit ne peut être reproduite sous quelque forme ni par quelque moyen que ce soit, électronique ou mécanique, y compris des systèmes de stockage et de récupération d'informations, sans l'autorisation écrite préalable de l'IB. De plus, la licence associée à ce produit interdit toute utilisation de tout fichier ou extrait sélectionné dans ce produit. L'utilisation par des tiers, y compris, sans toutefois s'y limiter, des éditeurs, des professeurs particuliers, des services de tutorat ou d'aide aux études, des établissements de préparation à l'enseignement supérieur, des fournisseurs de services de planification des programmes d'études, des gestionnaires de plateformes pédagogiques en ligne, et des développeurs d'applications, moyennant paiement ou non, est interdite et constitue une infraction pénale.

Pour plus d'informations sur la procédure à suivre pour obtenir une autorisation écrite sous la forme d'une licence, rendez-vous à l'adresse <https://ibo.org/become-an-ib-school/ib-publishing/licensing/applying-for-a-license/>.

© Organización del Bachillerato Internacional, 2024

Todos los derechos reservados. No se podrá reproducir ninguna parte de este producto de ninguna forma ni por ningún medio electrónico o mecánico, incluidos los sistemas de almacenamiento y recuperación de información, sin la previa autorización por escrito del IB. Además, la licencia vinculada a este producto prohíbe el uso de todo archivo o fragmento seleccionado de este producto. El uso por parte de terceros —lo que incluye, a título enunciativo, editoriales, profesores particulares, servicios de apoyo académico o ayuda para el estudio, colegios preparatorios, desarrolladores de aplicaciones y entidades que presten servicios de planificación curricular u ofrezcan recursos para docentes mediante plataformas digitales—, ya sea incluido en tasas o no, está prohibido y constituye un delito.

En este enlace encontrará más información sobre cómo solicitar una autorización por escrito en forma de licencia: <https://ibo.org/become-an-ib-school/ib-publishing/licensing/applying-for-a-license/>.

Instructions to Examiners

Abbreviations

- M** Marks awarded for attempting to use a correct **Method**.
- A** Marks awarded for an **Answer** or for **Accuracy**; often dependent on preceding **M** marks.
- R** Marks awarded for clear **Reasoning**.
- AG** Answer given in the question and so no marks are awarded.
- FT** Follow through. The practice of awarding marks, despite candidate errors in previous parts, for their correct methods/answers using incorrect results.

Using the markscheme

1 General

Award marks using the annotations as noted in the markscheme eg **M1**, **A2**.

2 Method and Answer/Accuracy marks

- Do **not** automatically award full marks for a correct answer; all working **must** be checked, and marks awarded according to the markscheme.
- It is generally not possible to award **M0** followed by **A1**, as **A** mark(s) depend on the preceding **M** mark(s), if any.
- Where **M** and **A** marks are noted on the same line, e.g. **M1A1**, this usually means **M1** for an **attempt** to use an appropriate method (e.g. substitution into a formula) and **A1** for using the **correct** values.
- Where there are two or more **A** marks on the same line, they may be awarded independently; so if the first value is incorrect, but the next two are correct, award **A0A1A1**.
- Where the markscheme specifies **A3**, **M2** etc., do **not** split the marks, unless there is a note.
- The response to a “show that” question does not need to restate the **AG** line, unless a **Note** makes this explicit in the markscheme.
- Once a correct answer to a question or part question is seen, ignore further working even if this working is incorrect and/or suggests a misunderstanding of the question. This will encourage a uniform approach to marking, with less examiner discretion. Although some candidates may be advantaged for that specific question item, it is likely that these candidates will lose marks elsewhere too.
- An exception to the previous rule is when an incorrect answer from further working is used **in a subsequent part**. For example, when a correct exact value is followed by an incorrect decimal approximation in the first part and this approximation is then used in the second part. In this situation, award **FT** marks as appropriate but do not award the final **A1** in the first part. Examples:

	Correct answer seen	Further working seen	Any FT issues?	Action
1.	$8\sqrt{2}$	5.65685... (incorrect decimal value)	No. Last part in question.	Award A1 for the final mark (condone the incorrect further working)
2.	$\frac{35}{72}$	0.468111... (incorrect decimal value)	Yes. Value is used in subsequent parts.	Award A0 for the final mark (and full FT is available in subsequent parts)

3 Implied marks

Implied marks appear in **brackets e.g. (M1)**, and can only be awarded if **correct** work is seen or implied by subsequent working/answer.

4 Follow through marks (only applied after an error is made)

Follow through (**FT**) marks are awarded where an incorrect answer from one **part** of a question is used correctly in **subsequent** part(s) (e.g. incorrect value from part (a) used in part (d) or incorrect value from part (c)(i) used in part (c)(ii)). Usually, to award **FT** marks, **there must be working present** and not just a final answer based on an incorrect answer to a previous part. However, if all the marks awarded in a subsequent part are for the answer or are implied, then **FT** marks should be awarded for *their* correct answer, even when working is not present.

For example: following an incorrect answer to part (a) that is used in subsequent parts, where the markscheme for the subsequent part is **(M1)A1**, it is possible to award full marks for *their* correct answer, **without working being seen**. For longer questions where all but the answer marks are implied this rule applies but may be overwritten by a **Note** in the Markscheme.

- Within a question part, once an **error** is made, no further **A** marks can be awarded for work which uses the error, but **M** marks may be awarded if appropriate.
- If the question becomes much simpler because of an error then use discretion to award fewer **FT** marks, by reflecting on what each mark is for and how that maps to the simplified version.
- If the error leads to an inappropriate value (e.g. probability greater than 1, $\sin \theta = 1.5$, non-integer value where integer required), do not award the mark(s) for the final answer(s).
- The markscheme may use the word “their” in a description, to indicate that candidates may be using an incorrect value.
- If the candidate’s answer to the initial question clearly contradicts information given in the question, it is not appropriate to award any **FT** marks in the subsequent parts. This includes when candidates fail to complete a “show that” question correctly, and then in subsequent parts use their incorrect answer rather than the given value.
- Exceptions to these **FT** rules will be explicitly noted on the markscheme.
- If a candidate makes an error in one part but gets the correct answer(s) to subsequent part(s), award marks as appropriate, unless the command term was “Hence”.

5 Mis-read

If a candidate incorrectly copies values or information from the question, this is a mis-read (**MR**). A candidate should be penalized only once for a particular misread. Use the **MR** stamp to indicate that this has been a misread and do not award the first mark, even if this is an **M** mark, but award all others as appropriate.

- If the question becomes much simpler because of the **MR**, then use discretion to award fewer marks.
- If the **MR** leads to an inappropriate value (e.g. probability greater than 1, $\sin \theta = 1.5$, non-integer value where integer required), do not award the mark(s) for the final answer(s).
- Miscopying of candidates' own work does **not** constitute a misread, it is an error.
- If a candidate uses a correct answer, to a "show that" question, to a higher degree of accuracy than given in the question, this is NOT a misread and full marks may be scored in the subsequent part.
- **MR** can only be applied when work is seen. For calculator questions with no working and incorrect answers, examiners should **not** infer that values were read incorrectly.

6 Alternative methods

Candidates will sometimes use methods other than those in the markscheme. Unless the question specifies a method, other correct methods should be marked in line with the markscheme. If the command term is 'Hence' and not 'Hence or otherwise' then alternative methods are not permitted unless covered by a note in the mark scheme.

- Alternative methods for complete questions are indicated by **METHOD 1**, **METHOD 2**, etc.
- Alternative solutions for parts of questions are indicated by **EITHER . . . OR**.

7 Alternative forms

Unless the question specifies otherwise, **accept** equivalent forms.

- As this is an international examination, accept all alternative forms of **notation** for example 1.9 and 1,9 or 1000 and 1,000 and 1.000.
- Do not accept final answers written using calculator notation. However, **M** marks and intermediate **A** marks can be scored, when presented using calculator notation, provided the evidence clearly reflects the demand of the mark.
- In the markscheme, equivalent **numerical** and **algebraic** forms will generally be written in brackets immediately following the answer.
- In the markscheme, some **equivalent** answers will generally appear in brackets. Not all equivalent notations/answers/methods will be presented in the markscheme and examiners are asked to apply appropriate discretion to judge if the candidate work is equivalent.

8 Format and accuracy of answers

If the level of accuracy is specified in the question, a mark will be linked to giving the answer to the required accuracy. If the level of accuracy is not stated in the question, the general rule applies to final answers: *unless otherwise stated in the question all numerical answers must be given exactly or correct to three significant figures.*

Where values are used in subsequent parts, the markscheme will generally use the exact value, however candidates may also use the correct answer to a “correct” level of accuracy (e.g 3 sf) in subsequent parts. The markscheme will often explicitly include the subsequent values that come “from the use of 3 sf values”.

Simplification of final answers: Candidates are advised to give final answers using good mathematical form. In general, for an **A** mark to be awarded, arithmetic should be completed, and any values that lead to integers should be simplified; for example, $\sqrt{\frac{25}{4}}$ should be written as $\frac{5}{2}$.

An exception to this is simplifying fractions, where lowest form is not required (although the numerator and the denominator must be integers); for example, $\frac{10}{4}$ may be left in this form or written as $\frac{5}{2}$. However, $\frac{10}{5}$ should be written as 2, as it simplifies to an integer.

Algebraic expressions should be simplified by completing any operations such as addition and multiplication, e.g. $4e^{2x} \times e^{3x}$ should be simplified to $4e^{5x}$, and $4e^{2x} \times e^{3x} - e^{4x} \times e^x$ should be simplified to $3e^{5x}$. Unless specified in the question, expressions do not need to be factorized, nor do factorized expressions need to be expanded, so $x(x+1)$ and $x^2 + x$ are both acceptable.

Please note: intermediate **A** marks do NOT need to be simplified.

9 Calculators

A GDC is required for this paper, but If you see work that suggests a candidate has used any calculator not approved for IB DP examinations (eg CAS enabled devices), please follow the procedures for malpractice.

10. Presentation of candidate work

Crossed out work: If a candidate has drawn a line through work on their examination script, or in some other way crossed out their work, do not award any marks for that work unless an explicit note from the candidate indicates that they would like the work to be marked.

More than one solution: Where a candidate offers two or more different answers to the same question, an examiner should only mark the first response unless the candidate indicates otherwise. If the layout of the responses makes it difficult to judge, examiners should apply appropriate discretion to judge which is “first”.

1. (a) **EITHER**

N = 72		N = 6
I = 1.25		I = 1.25
PV = -3000	OR	PV = -3000

P/Y = 12		P/Y = 1
C/Y = 12		C/Y = 12

(M1)(A1)

Note: Award **M1** for attempt to use finance app on GDC, **A1** for all entries correct.

OR

$$3000 \left(1 + \frac{1.25}{1200} \right)^{72}$$

(M1)(A1)

Note: Award **M1** for using CI formula, **A1** for correct entries.

THEN

$$FV = (\$) 3233.53$$

A1

Note: Answer must be correct to 2 dp for the final **A1** to be awarded.

[3 marks]

(b) **EITHER**

I = 1.25		I = 1.25
PV = -3000		PV = -3000
FV = 3550	OR	FV = 3550

P/Y = 12		P/Y = 1
C/Y = 12		C/Y = 12

(A1)

Note: Award **A1** for all entries correct and opposite signs for PV and FV values.

OR

$$3550 = 3000 \left(1 + \frac{1.25}{1200} \right)^{12N}$$

(A1)

Note: Award **A1** for all entries correct.

THEN

$$N = 162 \text{ (161.686...)} \text{ (months)}$$

A1

[2 marks]

(c) 18450

A1

[1 mark]

(d) **EITHER**

N = 96		N = 96
I = 12.6		I = 1.05
PV = -18450	OR	PV = -18450
FV = 0		FV = 0
P/Y = 12		P/Y = 1
C/Y = 12		C/Y = 1

(M1)(A1)

Note: Award **M1** for attempt to use finance app on GDC, **A1** for N=96, PV=-18450 and FV=0,

THEN

PMT = (\$) 306

A1

Note: The answer must be correct to the nearest dollar for the final **A1** to be awarded.

[3 marks]

[Total: 9 marks]

2. (a) (i) recognition of binomial distribution (condone incorrect parameter) **(M1)**

e.g. $M \sim B(20, 0.04)$ **OR** $P(M = 2) = \text{binpdf}(20, 0.04, 2)$
= 0.146 (0.145799...)

A1

(ii) recognition the cumulative probability required **(M1)**

e.g. $P(M \geq 3) = 1 - \text{bincdf}(20, 0.04, 2)$ **OR** $\text{bincdf}(20, 0.04, 3, 20)$
= 0.0439 (0.0438627...)

A1

[4 marks]

(b) either one of two terms in expected value formula correct **(M1)**

$50(20(0.96)) + 15(20(0.04))$
= 972 (pesos)

A1

[2 marks]

[Total: 6 marks]

3. (a) correct substitution of 0.0003 into the formula (A1)
 $\text{pH} = -\log_{10}(0.0003)$
 $= 3.52 \text{ (3.52287...)}$ A1
[2 marks]

- (b) **EITHER** (M1)
 attempt to change to exponential form

$$[\text{H}^+] = 10^{-6.6}$$

OR

attempt to solve $6.6 = -\log_{10}[\text{H}^+]$

(graphically or using numerical solver)

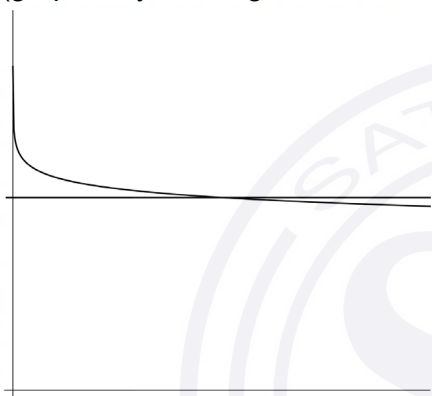

THEN

$$[\text{H}^+] = 0.000000251 \text{ (moles per litre) } \quad (0.000000251188..., 2.51 \times 10^{-7}) \quad \text{A1}$$

Note: Award **M1A0** for an answer of 2.51 (2.51188...) seen.
 Award **MOA0** if a substitution of 6.6 into the formula is seen without an answer or some indication of using numerical solver.

[2 marks]

- (c) $2 = -\log_{10}[\text{H}^+]$, $4.5 = -\log_{10}[\text{H}^+]$ (A1)
 $10^{-2} \text{ (0.01) } \quad \text{OR} \quad 10^{-4.5} \text{ (0.0000316227...)}$

substitution of their values into correct ratio (M1)

$$\frac{10^{-2}}{10^{-4.5}} \quad \text{OR} \quad \frac{0.01}{0.0000316227...}$$

$$= 316.227... = 316 \quad \text{A1}$$

Note: Some candidates may subtract logs and hence look to solve $\log_{10}[\text{H}^+] = 2.5$.

[3 marks]
 [Total: 7 marks]

4. (a) recognizing that only way to score 7 is to achieve a head and a 6 on die (M1)
 e.g. $\frac{1}{6}$ and $\frac{1}{2}$ seen in an attempt to combine probabilities

$$\left(\frac{1}{6} \times \frac{1}{2} =\right) \frac{1}{12} \text{ (0.0833333...)} \quad \text{A1}$$

Note: Condone 0.0835 from the use of 0.167.

[2 marks]

- (b) there are two ways to score (e.g.) 5 (M1)
 achieve a head and a 4 on die, or a tail and a 5 on die

$$\left(2\left(\frac{1}{6} \times \frac{1}{2}\right) =\right) \frac{2}{12} \left(\frac{1}{6}, 0.167, 0.16666...\right) \quad \text{A1}$$

Note: Award these marks for equivalent working for the 2, 3, 4 or 6 point scenarios.

Final Score	1	2	3	4	5	6	7
Probability	$\frac{1}{12}$	$\frac{1}{6}$	$\frac{1}{6}$	$\frac{1}{6}$	$\frac{1}{6}$	$\frac{1}{6}$	$\frac{1}{12}$

A1

Note: Award **A1** for a completely correct table. Award at most **(M1)A1A0** if their follow-through answer from part (a) leads to a total probability not equal to 1.

[3 marks]

- (c) **EITHER** (M1)
 multiplying at least two columns from their table

$$1 \times \frac{1}{12} + 2 \times \frac{1}{6} + \dots + 6 \times \frac{1}{6} + 7 \times \frac{1}{12}$$

- OR** (M1)
 recognizing the probabilities in the table are symmetric

- OR** (for HL markscheme and/or removed from SL at publication) (M1)
 Considering the sum of two random variables

$$E(X + Y) = E(X) + E(Y) \quad (= 3.5 + 0.5)$$

- THEN** (A1)
 (expected value =) 4

Note: Accept 4.01 (4.00640...) from use of their 3 sf values from (b).
 Award at most **M1A0** if their final answer is not in the range 1 – 7

[2 marks]

[Total: 7 marks]

5. (a) recognizing that the growth in one year is the difference in the two heights (M1)
 $5 \times 0.8 = 4$ (m) A1

[2 marks]

- (b) recognizing geometric sequence, $r = 0.8$ (M1)
 attempt to find total height by adding initial height to a term in series (M1)
EITHER

$$42 + \frac{4(1 - (0.8)^6)}{1 - (0.8)} \quad (A1)$$

OR

$$37 + \frac{5(1 - (0.8)^7)}{1 - (0.8)} \quad (A1)$$

THEN

$$= 56.7571\dots$$

$$= 56.76 \text{ (m)} \quad \text{OR} \quad 5676 \text{ (cm)} \quad A1$$

Note: Accept an answer in cm or in m to two decimal places.
--

[4 marks]

- (c) attempt to use infinite geometric series to find the total growth of the tree (M1)

e.g. $\frac{5}{1 - 0.8}$ **OR** $\frac{4}{1 - 0.8}$

$$\left(S_{\infty} = 37 + \frac{5}{1 - 0.8}, S_{\infty} = 42 + \frac{4}{1 - 0.8} \right)$$

$$k = 62$$

A1

[2 marks]

[Total: 8 marks]

6. attempt to substitute into area of triangle formula (M1)
 (sheep's field area =) $0.5 \times 15 \times 21 \times \sin(78^\circ)$
 $= 154.058\dots$ (m²) (A1)

EITHER

(goat's field area =) $\frac{282}{360} \times \pi \times 8^2$ (A1)(A1)

Note: Award **A1** for 282, **A1** for correct entries in formula (including their 282).

OR

$\pi \times 8^2 - \frac{78}{360} \times \pi \times 8^2$ (M1)(A1)

Note: Award **A1** for minor sector area, **M1** for subtracting their sector area from circle area.

THEN

$= 157.498\dots \left(\frac{752\pi}{15} \right)$ (m²) (A1)

the goat has most area by 3.44 (m²) (3.44026...) (A1)

Note: Accept 154 and 157 for the intermediate **A1** marks, but do NOT follow through within the question; a final answer of 3 m² is awarded **A0**.

[Total: 6 marks]

7. attempt at Euler (M1)

$y_{n+1} = (y_n x_n - 1)0.1 + y_n$ (A1)

x	1	1.1	1.2	1.3	1.4	1.5
y	2	2.1	2.231	2.39872	2.61055...	2.87603...

(A1)

Note: Any correct value either as a separate calculation or as part of a table, (including the result).

$y = 2.88$ (2.87603...)

(A1)
 [Total: 4 marks]

8. (a) $\begin{pmatrix} 1 \\ 1 \\ 2 \end{pmatrix}$

A1

Note: Accept any valid vector notation. Do not accept (1, 1, 2).

[1 mark]

(b) (i) **EITHER**

use of scalar product formula to find angle $\hat{B}AD$

(M1)

$$\cos \hat{B}AD = \frac{\begin{pmatrix} 3 \\ 4 \\ 0 \end{pmatrix} \cdot \begin{pmatrix} 1 \\ 1 \\ 2 \end{pmatrix}}{5\sqrt{6}}$$

(A1)

OR

use of cosine rule to find $\hat{B}AD$

(M1)

$$\cos \hat{B}AD = \frac{6 + 25 - 17}{2 \times \sqrt{6} \times 5}$$

(A1)

THEN

$$\hat{B}AD = 55.1^\circ \text{ (55.1417...}^\circ, 0.962405\text{...)}$$

A1

Note: If the direction of one of the vectors is reversed, leading to an obtuse angle (124.858... $^\circ$) between the vectors, then award **M1A1A0**.

(ii) **EITHER**

an attempt at using vector product

(M1)

$$\frac{1}{2} \left| \begin{pmatrix} 1 \\ 1 \\ 2 \end{pmatrix} \times \begin{pmatrix} 3 \\ 4 \\ 0 \end{pmatrix} \right| \text{ or equivalent}$$

attempt to apply formula (e.g. one correct component)

(M1)

$$= \frac{1}{2} ((1 \times 0 - 4 \times 2)\mathbf{i} - (1 \times 0 - 2 \times 3)\mathbf{j} - (1 \times 4 - 1 \times 3)\mathbf{k})$$

$$\frac{1}{2} \left| \begin{pmatrix} -8 \\ 6 \\ 1 \end{pmatrix} \right|$$

(A1)

$$= 5.02 \left(5.02493, \frac{\sqrt{101}}{2} \right)$$

A1

OR

use of formula for the area of a triangle

(M1)

$$\text{area} = \frac{1}{2} \begin{vmatrix} 3 \\ 4 \\ 0 \end{vmatrix} \begin{vmatrix} 1 \\ 1 \\ 2 \end{vmatrix} \sin 55.1417\dots$$

$$= 5.02$$

(A1)(A1)

A1

Note: Award **A1** for the lengths AB and AD and **A1** for the angle.

[7 marks]

(c) **EITHER**

$$\vec{AD} = \vec{BC} = \begin{pmatrix} 1 \\ 1 \\ 2 \end{pmatrix} \quad \text{OR} \quad \vec{AB} = \vec{DC} = \begin{pmatrix} 3 \\ 4 \\ 0 \end{pmatrix}$$

A1

One pair of opposite sides have equal length AND are parallel

R1

OR

$$\vec{AD} = \begin{pmatrix} 1 \\ 1 \\ 2 \end{pmatrix}, \vec{BC} = \begin{pmatrix} 1 \\ 1 \\ 2 \end{pmatrix}, \vec{AB} = \begin{pmatrix} 3 \\ 4 \\ 0 \end{pmatrix}, \vec{DC} = \begin{pmatrix} 3 \\ 4 \\ 0 \end{pmatrix}$$

A1

$$\vec{AD} = \vec{BC} = \begin{pmatrix} 1 \\ 1 \\ 2 \end{pmatrix} \quad \text{and} \quad \vec{AB} = \vec{DC} = \begin{pmatrix} 3 \\ 4 \\ 0 \end{pmatrix}$$

both pairs of opposite sides are parallel (or have equal length)

R1

Note: Both pairs of opposite angles are equal is also valid.

THEN

hence ABCD is a parallelogram

AG

[2 marks]

[Total: 8 marks]

9. (a) (i) let X be number of accidents per week $\Rightarrow X \sim \text{Po}(0.76)$
 recognition cumulative Poisson distribution **(M1)**
 $P(X \geq 2) = 1 - P(X \leq 1)$
 $= 0.177$ (0.176907...) **A1**

(ii) let F be number of accidents per 4-week $\Rightarrow F \sim \text{Po}(3.04)$ **(M1)**
 $P(Y = 3) = 0.224$ (0.223982...) **A1**

[4 marks]

(b) binomial model **A1**
 with $p = 0.177$ **OR** $p = 1 - 0.177 (= 0.823)$ and $n = 8$ **A1**

[2 marks]

[Total: 6 marks]

10. (a)

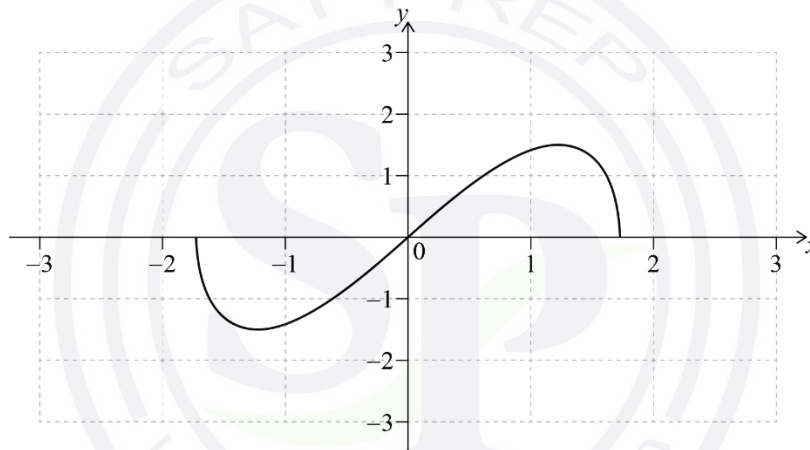

A1A1

Note: Award **A1** smooth curve, through origin, with maximum in 1st quadrant and minimum in 3rd quadrant (approximately correct position).
 Award **A1** correct (approximate) position of endpoints and rotational symmetry.
 Condone a (small) gap between end of curve and the x -axis.

[2 marks]

(b) (i) $2\pi \int_0^{\sqrt{3}} (x\sqrt{3-x^2})^2 dx$ **OR** $\pi \int_{-\sqrt{3}}^{\sqrt{3}} (x\sqrt{3-x^2})^2 dx$ (or equivalent) **A1A1**

Note: Award **A1** for integral with correct limits in the correct places, **A1** for completely correct expression;
 dx must be included. Condone a correct answer presented as two integrals,
 despite the demand of the question: $\pi \left(\int_{-\sqrt{3}}^0 (x\sqrt{3-x^2})^2 dx + \int_0^{\sqrt{3}} (x\sqrt{3-x^2})^2 dx \right)$.

(ii) $13.1 \left(13.0593..., \frac{12\pi\sqrt{3}}{5} \right)$ **A2**

[4 marks]

(c) attempt to express $g(x)$ in terms of $f(x)$ (M1)

$$g(x) = \frac{1}{2} \left(\frac{x}{2} \sqrt{3 - \left(\frac{x}{2}\right)^2} \right), \quad g(x) = \frac{1}{2} f\left(\frac{x}{2}\right)$$

correct limits for g seen: $-2\sqrt{3}$ and $2\sqrt{3}$ (A1)

$$\pi \int_{-2\sqrt{3}}^{2\sqrt{3}} \left(\frac{1}{2} \left(\frac{x}{2} \sqrt{3 - \left(\frac{x}{2}\right)^2} \right) \right)^2 dx \quad \text{OR} \quad \pi \int_{-2\sqrt{3}}^{2\sqrt{3}} \left(\frac{1}{2} f\left(\frac{x}{2}\right) \right)^2 dx \quad \text{OR} \quad 2 \times \frac{1}{2} \times \left(\frac{12\pi\sqrt{3}}{5} \right)$$

$$6.53 \left(6.52967\dots, \frac{6\pi\sqrt{3}}{5} \right) \quad \text{A1}$$

Note: Some candidates may answer question by transforming their part (b)(ii):

$$2 \times \frac{1}{2} \times \left(\frac{12\pi\sqrt{3}}{5} \right). \text{ This is a valid method and leads to the correct answer.}$$

[3 marks]
[Total: 9 marks]

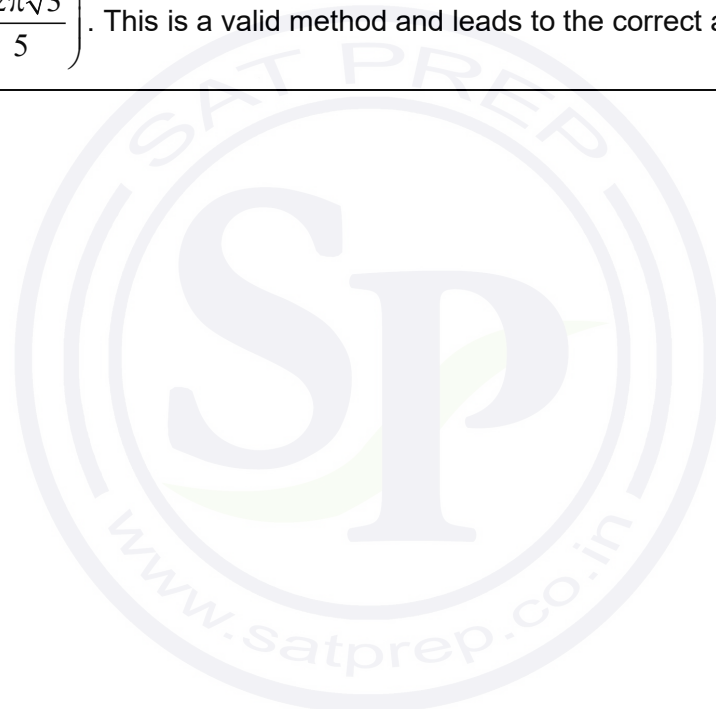

11. (a) $y = kx^2 - x$

$$\frac{dy}{dx} = 2kx - 1 \quad \text{(A1)}$$

$$m_{\text{tan}} = 1 \quad \text{A1}$$

finding negative reciprocal of their gradient (M1)

$$m_{\text{normal}} = -1$$

$$\text{normal: } y = -\left(x - \frac{1}{k}\right) \quad \text{A1}$$

equating normal line to quadratic curve M1

$$kx^2 - x = -\left(x - \frac{1}{k}\right)$$

correct simplification leading to given result A1

e.g. quadratic formula or difference of two squares

$$kx^2 - \frac{1}{k} = 0$$

$$k^2x^2 - 1 = 0$$

$$(kx - 1)(kx + 1) = 0$$

$$x = -\frac{1}{k}$$

AG

[6 marks]

$$(b) \text{ area} = \int_{-\frac{1}{2}}^{\frac{1}{2}} \left(x - \frac{1}{2}\right) - (2x^2 - x) \, dx \quad \text{(M1)(A1)}$$

Note: Award **M1** for evidence of subtracting the functions and **A1** for a completely correct integral. (Condone a missing dx.)

$$= 0.333 \left(0.333333\dots, \frac{1}{3}\right) \quad \text{A1}$$

[3 marks]

[Total: 9 marks]

12. (a) $\sqrt{6^2 + 6^2 + 3^2}$
 $= 9 \text{ (ms}^{-1}\text{)}$ (A1)
 A1
 [2 marks]
- (b) $\mathbf{h} = \begin{pmatrix} -38 \\ 134 \\ 315 \end{pmatrix} + t \begin{pmatrix} 15 \\ -20 \\ -60 \end{pmatrix}$ A1
 [1 mark]
- (c) equating one component from each (M1)
 e.g. $7 + 6t = -38 + 15t$
 $t = 5$ (A1)
 substituting their t -value into either equation (M1)
- $$\begin{pmatrix} -38 \\ 134 \\ 315 \end{pmatrix} + 5 \begin{pmatrix} 15 \\ -20 \\ -60 \end{pmatrix}$$
- $$= \begin{pmatrix} 37 \\ 34 \\ 15 \end{pmatrix}$$
- A1
 [4 marks]
 [Total: 7 marks]
13. (a) $3 \sin(a)(1 + \cos(a)) = 0$ (M1)
 $a = 3.14 \text{ (}\pi\text{, } 3.14159\dots)$ A1
 [2 marks]
- (b) attempt to find the maximum velocity (M1)
 e.g. $\frac{dv}{dt} = 0$ OR sketch of v with maximum marked
 $v_{\max} = 3.90 \text{ (ms}^{-1}\text{)} \text{ (} 3.89711\dots)$ A1
- Note:** Accept 3.9 rounded to 2 sf.
- [2 marks]
- (c) attempt to find integral of speed (condone omission of modulus signs) (M1)
 $\int_0^\pi |3 \sin(t)(1 + \cos(t))| dt$ OR 6
 attempt to substitute into $\text{speed} = \frac{\text{distance}}{\text{time}}$ (M1)
- $$= \frac{\int_0^\pi |3 \sin(t)(1 + \cos(t))| dt}{\pi}$$
- (A1)
 $= 1.91 \text{ (ms}^{-1}\text{)} \text{ (} 1.90985\dots, \frac{6}{\pi}\text{)}$ A1
 [4 marks]
 [Total: 8 marks]

14. (a) room temperature / the temperature below which the hot water will not cool **A1**

Note: Accept answers similar to “the temperature of the water in the cup after 25 minutes”.

[1 mark]

- (b) evidence of subtracting 25 from the temperature data **(M1)**
 $a = 244$ (243.920...) and $b = -1.03$ (-1.02965...) **A1A1**

Note: Award **MOA1A0** for both answers $a = 116.764...$ and $b = -0.375218...$ seen, from not subtracting the 25.

[3 marks]

- (c) $k = 61.1$ (61.0848...) and $c = 0.923$ (0.923029...) **A1**

Note: If not subtracting 25 was penalized in part (b), award **A1** for $k = 68.9023...$ and $c = 0.972506...$ seen in part (c).

[1 mark]

- (d) Award **R1** for any appropriate reason that supports Soo Min’s model
e.g.

EITHER

compare r^2 values: 0.76573583... and 0.9233117... **R1**

OR

consider value at $t = 0$ / “water cannot reach a temperature more than 100 degrees” **R1**

Note: If subtracting 25 was penalized in (b) then award **R1** for comparing r^2 values 0.904086... and 0.994522...

Award **R1** for correct reasoning seen for the use of comparison of the sum of square residuals.

[1 mark]

[Total: 8 marks]

15. (a) $\sqrt{2} e^{\frac{3\pi i}{4}}$ A1A1
[2 marks]

(b) (i) enlargement SF $\sqrt{2}$, (1.41, 1.41421...), (centre (0, 0)) A1

rotation of $\frac{3\pi}{4}$, (2.36, 2.35619...), (centre (0, 0)) A1

(ii) $\begin{pmatrix} \sqrt{2} & 0 \\ 0 & \sqrt{2} \end{pmatrix} \begin{pmatrix} \cos\left(\frac{3\pi}{4}\right) & -\sin\left(\frac{3\pi}{4}\right) \\ \sin\left(\frac{3\pi}{4}\right) & \cos\left(\frac{3\pi}{4}\right) \end{pmatrix}$ (A1)(A1)

Note: The order of matrix multiplication does not matter in this case.

$= \begin{pmatrix} -1 & -1 \\ 1 & -1 \end{pmatrix}$ A1

Note: Do not **FT** if their matrices in part (b)(i) are not representative of a dilation AND a rotation.

[5 marks]

(c) 8 A1

Note: Since $\frac{3\pi n}{4}$ must be a multiple of 2π .

[1 mark]
[Total: 8 marks]

Markscheme

November 2023

**Mathematics:
applications and interpretation**

Higher level

Paper 1

© International Baccalaureate Organization 2023

All rights reserved. No part of this product may be reproduced in any form or by any electronic or mechanical means, including information storage and retrieval systems, without the prior written permission from the IB. Additionally, the license tied with this product prohibits use of any selected files or extracts from this product. Use by third parties, including but not limited to publishers, private teachers, tutoring or study services, preparatory schools, vendors operating curriculum mapping services or teacher resource digital platforms and app developers, whether fee-covered or not, is prohibited and is a criminal offense.

More information on how to request written permission in the form of a license can be obtained from <https://ibo.org/become-an-ib-school/ib-publishing/licensing/applying-for-a-license/>.

© Organisation du Baccalauréat International 2023

Tous droits réservés. Aucune partie de ce produit ne peut être reproduite sous quelque forme ni par quelque moyen que ce soit, électronique ou mécanique, y compris des systèmes de stockage et de récupération d'informations, sans l'autorisation écrite préalable de l'IB. De plus, la licence associée à ce produit interdit toute utilisation de tout fichier ou extrait sélectionné dans ce produit. L'utilisation par des tiers, y compris, sans toutefois s'y limiter, des éditeurs, des professeurs particuliers, des services de tutorat ou d'aide aux études, des établissements de préparation à l'enseignement supérieur, des fournisseurs de services de planification des programmes d'études, des gestionnaires de plateformes pédagogiques en ligne, et des développeurs d'applications, moyennant paiement ou non, est interdite et constitue une infraction pénale.

Pour plus d'informations sur la procédure à suivre pour obtenir une autorisation écrite sous la forme d'une licence, rendez-vous à l'adresse <https://ibo.org/become-an-ib-school/ib-publishing/licensing/applying-for-a-license/>.

© Organización del Bachillerato Internacional, 2023

Todos los derechos reservados. No se podrá reproducir ninguna parte de este producto de ninguna forma ni por ningún medio electrónico o mecánico, incluidos los sistemas de almacenamiento y recuperación de información, sin la previa autorización por escrito del IB. Además, la licencia vinculada a este producto prohíbe el uso de todo archivo o fragmento seleccionado de este producto. El uso por parte de terceros —lo que incluye, a título enunciativo, editoriales, profesores particulares, servicios de apoyo académico o ayuda para el estudio, colegios preparatorios, desarrolladores de aplicaciones y entidades que presten servicios de planificación curricular u ofrezcan recursos para docentes mediante plataformas digitales—, ya sea incluido en tasas o no, está prohibido y constituye un delito.

En este enlace encontrará más información sobre cómo solicitar una autorización por escrito en forma de licencia: <https://ibo.org/become-an-ib-school/ib-publishing/licensing/applying-for-a-license/>.

Instructions to Examiners

Abbreviations

- M** Marks awarded for attempting to use a correct **Method**.
- A** Marks awarded for an **Answer** or for **Accuracy**; often dependent on preceding **M** marks.
- R** Marks awarded for clear **Reasoning**.
- AG** Answer given in the question and so no marks are awarded.
- FT** Follow through. The practice of awarding marks, despite candidate errors in previous parts, for their correct methods/answers using incorrect results.

Using the markscheme

1 General

Award marks using the annotations as noted in the markscheme eg **M1**, **A2**.

2 Method and Answer/Accuracy marks

- Do **not** automatically award full marks for a correct answer; all working **must** be checked, and marks awarded according to the markscheme.
- It is generally not possible to award **M0** followed by **A1**, as **A** mark(s) depend on the preceding **M** mark(s), if any.
- Where **M** and **A** marks are noted on the same line, e.g. **M1A1**, this usually means **M1** for an **attempt** to use an appropriate method (e.g. substitution into a formula) and **A1** for using the **correct** values.
- Where there are two or more **A** marks on the same line, they may be awarded independently; so if the first value is incorrect, but the next two are correct, award **A0A1A1**.
- Where the markscheme specifies **A3**, **M2** etc., do **not** split the marks, unless there is a note.
- The response to a “show that” question does not need to restate the **AG** line, unless a **Note** makes this explicit in the markscheme.
- Once a correct answer to a question or part question is seen, ignore further working even if this working is incorrect and/or suggests a misunderstanding of the question. This will encourage a uniform approach to marking, with less examiner discretion. Although some candidates may be advantaged for that specific question item, it is likely that these candidates will lose marks elsewhere too.
- An exception to the previous rule is when an incorrect answer from further working is used **in a subsequent part**. For example, when a correct exact value is followed by an incorrect decimal approximation in the first part and this approximation is then used in the second part. In this situation, award **FT** marks as appropriate but do not award the final **A1** in the first part. Examples:

	Correct answer seen	Further working seen	Any FT issues?	Action
1.	$8\sqrt{2}$	5.65685... (incorrect decimal value)	No. Last part in question.	Award A1 for the final mark (condone the incorrect further working)
2.	$\frac{35}{72}$	0.468111... (incorrect decimal value)	Yes. Value is used in subsequent parts.	Award A0 for the final mark (and full FT is available in subsequent parts)

3 Implied marks

Implied marks appear in **brackets e.g. (M1)**, and can only be awarded if **correct** work is seen or implied by subsequent working/answer.

4 Follow through marks (only applied after an error is made)

Follow through (**FT**) marks are awarded where an incorrect answer from one **part** of a question is used correctly in **subsequent** part(s) (e.g. incorrect value from part (a) used in part (d) or incorrect value from part (c)(i) used in part (c)(ii)). Usually, to award **FT** marks, **there must be working present** and not just a final answer based on an incorrect answer to a previous part. However, if all the marks awarded in a subsequent part are for the answer or are implied, then **FT** marks should be awarded for *their* correct answer, even when working is not present.

For example: following an incorrect answer to part (a) that is used in subsequent parts, where the markscheme for the subsequent part is **(M1)A1**, it is possible to award full marks for *their* correct answer, **without working being seen**. For longer questions where all but the answer marks are implied this rule applies but may be overwritten by a **Note** in the Markscheme.

- Within a question part, once an **error** is made, no further **A** marks can be awarded for work which uses the error, but **M** marks may be awarded if appropriate.
- If the question becomes much simpler because of an error then use discretion to award fewer **FT** marks, by reflecting on what each mark is for and how that maps to the simplified version.
- If the error leads to an inappropriate value (e.g. probability greater than 1, $\sin \theta = 1.5$, non-integer value where integer required), do not award the mark(s) for the final answer(s).
- The markscheme may use the word “their” in a description, to indicate that candidates may be using an incorrect value.
- If the candidate’s answer to the initial question clearly contradicts information given in the question, it is not appropriate to award any **FT** marks in the subsequent parts. This includes when candidates fail to complete a “show that” question correctly, and then in subsequent parts use their incorrect answer rather than the given value.
- Exceptions to these **FT** rules will be explicitly noted on the markscheme.
- If a candidate makes an error in one part but gets the correct answer(s) to subsequent part(s), award marks as appropriate, unless the command term was “Hence”.

5 Mis-read

If a candidate incorrectly copies values or information from the question, this is a mis-read (**MR**). A candidate should be penalized only once for a particular misread. Use the **MR** stamp to indicate that this has been a misread and do not award the first mark, even if this is an **M** mark, but award all others as appropriate.

- If the question becomes much simpler because of the **MR**, then use discretion to award fewer marks.
- If the **MR** leads to an inappropriate value (e.g. probability greater than 1, $\sin \theta = 1.5$, non-integer value where integer required), do not award the mark(s) for the final answer(s).
- Miscopying of candidates' own work does **not** constitute a misread, it is an error.
- If a candidate uses a correct answer, to a "show that" question, to a higher degree of accuracy than given in the question, this is NOT a misread and full marks may be scored in the subsequent part.
- **MR** can only be applied when work is seen. For calculator questions with no working and incorrect answers, examiners should **not** infer that values were read incorrectly.

6 Alternative methods

Candidates will sometimes use methods other than those in the markscheme. Unless the question specifies a method, other correct methods should be marked in line with the markscheme. If the command term is 'Hence' and not 'Hence or otherwise' then alternative methods are not permitted unless covered by a note in the mark scheme.

- Alternative methods for complete questions are indicated by **METHOD 1**, **METHOD 2**, etc.
- Alternative solutions for parts of questions are indicated by **EITHER . . . OR**.

7 Alternative forms

Unless the question specifies otherwise, **accept** equivalent forms.

- As this is an international examination, accept all alternative forms of **notation** for example 1.9 and 1,9 or 1000 and 1,000 and 1.000.
- Do not accept final answers written using calculator notation. However, **M** marks and intermediate **A** marks can be scored, when presented using calculator notation, provided the evidence clearly reflects the demand of the mark.
- In the markscheme, equivalent **numerical** and **algebraic** forms will generally be written in brackets immediately following the answer.
- In the markscheme, some **equivalent** answers will generally appear in brackets. Not all equivalent notations/answers/methods will be presented in the markscheme and examiners are asked to apply appropriate discretion to judge if the candidate work is equivalent.

8 Format and accuracy of answers

If the level of accuracy is specified in the question, a mark will be linked to giving the answer to the required accuracy. If the level of accuracy is not stated in the question, the general rule applies to final answers: *unless otherwise stated in the question all numerical answers must be given exactly or correct to three significant figures.*

Where values are used in subsequent parts, the markscheme will generally use the exact value, however candidates may also use the correct answer to a “correct” level of accuracy (e.g 3 sf) in subsequent parts. The markscheme will often explicitly include the subsequent values that come “from the use of 3 sf values”.

Simplification of final answers: Candidates are advised to give final answers using good mathematical form. In general, for an **A** mark to be awarded, arithmetic should be completed, and any values that lead to integers should be simplified; for example, $\sqrt{\frac{25}{4}}$ should be written as $\frac{5}{2}$.

An exception to this is simplifying fractions, where lowest form is not required (although the numerator and the denominator must be integers); for example, $\frac{10}{4}$ may be left in this form or written as $\frac{5}{2}$. However, $\frac{10}{5}$ should be written as 2, as it simplifies to an integer.

Algebraic expressions should be simplified by completing any operations such as addition and multiplication, e.g. $4e^{2x} \times e^{3x}$ should be simplified to $4e^{5x}$, and $4e^{2x} \times e^{3x} - e^{4x} \times e^x$ should be simplified to $3e^{5x}$. Unless specified in the question, expressions do not need to be factorized, nor do factorized expressions need to be expanded, so $x(x+1)$ and $x^2 + x$ are both acceptable.

Please note: intermediate **A** marks do NOT need to be simplified.

9 Calculators

A GDC is required for this paper, but If you see work that suggests a candidate has used any calculator not approved for IB DP examinations (eg CAS enabled devices), please follow the procedures for malpractice.

10. Presentation of candidate work

Crossed out work: If a candidate has drawn a line through work on their examination script, or in some other way crossed out their work, do not award any marks for that work unless an explicit note from the candidate indicates that they would like the work to be marked.

More than one solution: Where a candidate offers two or more different answers to the same question, an examiner should only mark the first response unless the candidate indicates otherwise. If the layout of the responses makes it difficult to judge, examiners should apply appropriate discretion to judge which is “first”.

1. (a) attempt to use the term formula for a geometric sequence

(M1)

$$4 \times (0.8)^2$$
$$= 2.56 \text{ (mm)} \left(\frac{64}{25} \right)$$

A1

[2 marks]

- (b) attempt to use the sum formula for a geometric sequence

(M1)

$$\frac{4 \times (1 - 0.8^{12})}{1 - 0.8}$$
$$= 18.6 \text{ (mm)} \text{ (18.6256...)}$$

A1

[2 marks]

- (c) attempt to use infinite geometric sum

(M1)

e.g. $\frac{4}{1-0.8}$ **OR** 20

adding 25 to their expression or value
(maximum width = 25 + 20)

(M1)

45 (mm)

A1

[3 marks]

[Total 7 marks]

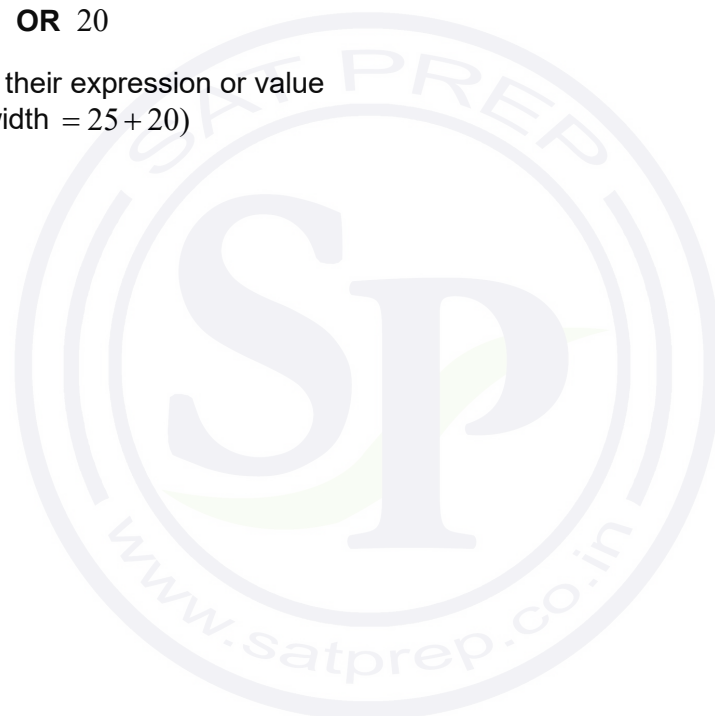

2. (a) 4

A1
[1 mark]

(b)

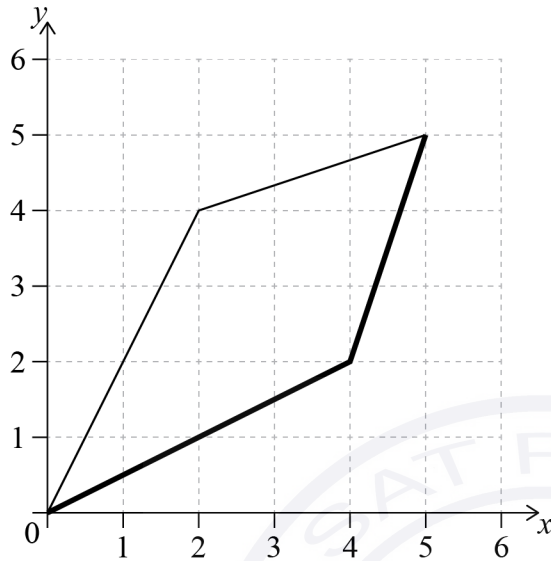

Note: Award **A1** for passing through (0, 0) and (4, 2),
A1 for passing through (4, 2) and (5, 5).

A1A1

[2 marks]

(c) attempt to solve $y = 3x - 1$ for x **OR** changing variables

(M1)

$$(g^{-1}(x)) = \frac{x+1}{3}$$

A1

[2 marks]

(d) sketch of $g(x)$ or $g^{-1}(x)$, algebraic approach

(M1)

$$\frac{1}{2}x = \frac{x+1}{3}$$

$$(x =) 2$$

A1

[2 marks]

[Total 7 marks]

3. (a) (upper bound =) 0.525 (m) A1
 (lower bound =) 0.515 (m) A1

Note: Accept an answer in interval notation or written as an inequality.

[2 marks]

- (b) **METHOD 1 Convert REC to linear metres** (M1)
 attempt to convert REC to metres using their lower bound
 $440 \times 0.515 (= 226.6)$ **OR** $280 \times 0.515 (= 144.2)$ seen

attempt to use the formula for the volume of a right pyramid (M1)

$$(V =) \frac{1}{3}(440 \times 0.515)^2(280 \times 0.515) \quad \text{(A1)}$$

$$2470000 \text{ (m}^3\text{)} \text{ (2468106.051\dots, } 2.47 \times 10^6\text{)} \quad \text{A1}$$

METHOD 2 Convert REC to cubic metres (M1)
 attempt to use the formula for the volume of a right pyramid

$$(V =) \frac{1}{3}(440)^2(280) (= 18069333.33\dots)$$

attempt to convert 1 cubic REC to cubic metres using their lower bound (M1)
 (1 cubic REC =) 0.515^3

$$(V =) \frac{1}{3}(440)^2(280) \times (0.515)^3 \quad \text{(A1)}$$

$$2470000 \text{ (m}^3\text{)} \text{ (2468106.051\dots, } 2.47 \times 10^6\text{)} \quad \text{A1}$$

[4 marks]

[Total 6 marks]

4. (a) recognizing supplementary angles or acute angles in right-triangles (M1)
 $(\hat{A}BC =) 41^\circ + (180^\circ - 112^\circ), 41^\circ + (90^\circ - 22^\circ)$

Note: Values may be seen on diagram.

$$\hat{A}BC = 109^\circ \quad \text{A1}$$

[2 marks]

- (b) $\hat{A}CB = 49^\circ$ (may be seen in part (a)) (A1)
 attempt to substitute into the sine rule (or equivalent) (M1)

$$\frac{AC}{\sin 109^\circ} = \frac{100}{\sin 49^\circ} \quad \text{(A1)}$$

$$AC = 125 \text{ (km)} \text{ (= 125.282\dots)} \quad \text{A1}$$

[4 marks]

[Total 6 marks]

5. (a) $2.36 = a(3)^2 + b(3) + c$ **OR** $2.36 = 9a + 3b + c$ **A1**
[1 mark]

(b) finding other equations to solve simultaneously **(M1)**

$5 = a(10)^2 + b(10) + c$ **AND** $7.16 = a(17)^2 + b(17) + c$
OR $5 = 100a + 10b + c$ **AND** $7.16 = 289a + 17b + c$

any one coefficient in equation correct **(A1)**
 $f(x) = -0.00490x^2 + 0.441x + 1.08$ **A1**

$(f(x) = -0.00489795\dots x^2 + 0.440816\dots x + 1.08163\dots)$
 $\left(f(x) = -\frac{6}{1225}x^2 + \frac{108}{245}x + \frac{53}{49} \right)$

Note: Award at most **(M1)(A1)A0** if answer is not expressed as an equation.

[3 marks]

(c) attempt to substitute 80 into their equation **(M1)**

$(f(80) =) 5$ **A1**

$5 > 4$ **OR** therefore the ball will go over the fence **R1**

Note: Do not award **A0R1**; their value must be seen to credit a correct conclusion.

[3 marks]

(d) setting their equation equal to zero, graph **(M1)**

$0 = -0.00489795\dots x^2 + 0.440816\dots x + 1.08163\dots$ **OR** $f(x) = 0$

92.4 (92.3902...) (m) **A1**

[2 marks]

[Total 9 marks]

6. (a) (4, 8) **A1**
[1 mark]
- (b) attempt to find the gradient of AC **(M1)**
 $\frac{13-3}{8-0}, \frac{10}{8}, \left(\frac{5}{4}\right), (1.25)$
 attempt to substitute **their** coordinates and the negative reciprocal of **their** gradient into the equation of a straight line **(M1)**
 $y-8 = -\frac{4}{5}(x-4)$ **OR** $8 = -\frac{4}{5}(4)+c$ **OR** $c=11.2$
 $y-8 = -\frac{4}{5}(x-4)$ ($y = -0.8x+11.2, 4x+5y-56=0$) **A1**
[3 marks]
- (c) (i) attempt to find one distance from a farm to any closest vertex **M1**
 finding a correct distance from at least two distinct vertices **A1**
 $7.58968\dots, 4.472135\dots (\sqrt{20}), 5.830951\dots (\sqrt{34})$
 $\left(\frac{9}{11}, \frac{116}{11}\right)$ (is furthest) **A1**
- (ii) 7.59 (km) (= 7.58968...) **A1**
[4 marks]
[Total 8 marks]

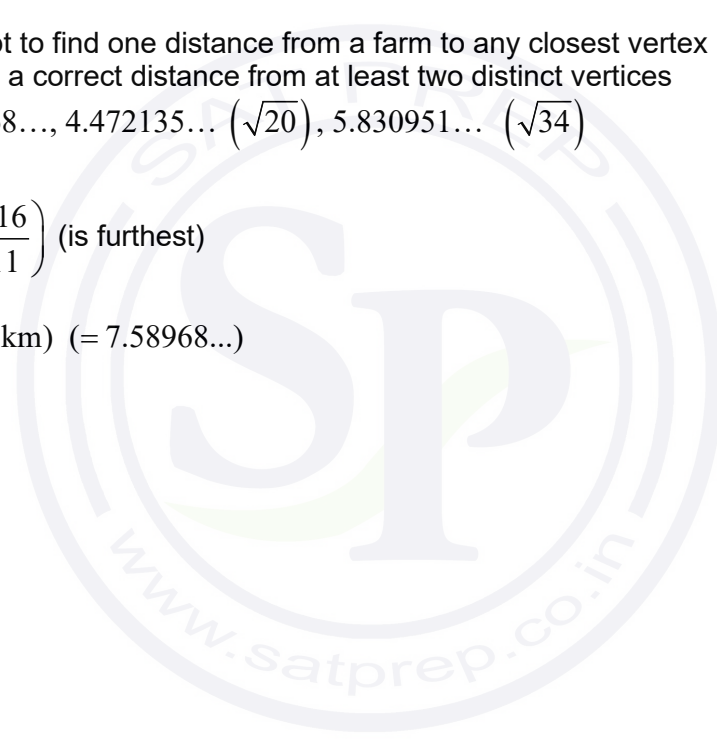

7. (a)

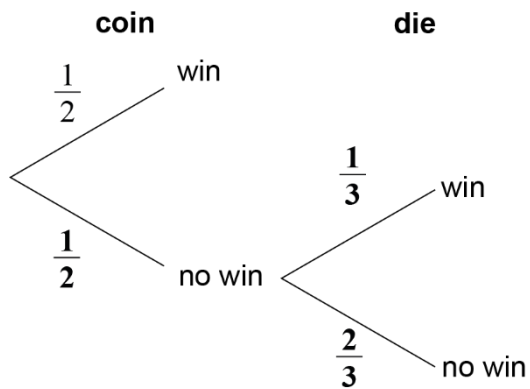

A1A1

Note: Award **A1** for completing first set of branches, **A1** for completing second set of branches.

[2 marks]

(b) attempt to multiply along the branches

(M1)

$$\frac{1}{2} \times \frac{2}{3}$$

$$= \frac{1}{3} \quad (= 0.333\dots)$$

A1

[2 marks]

(c) **EITHER**

$$\frac{\frac{1}{2}}{\frac{1}{2} + \left(\frac{1}{2} \times \frac{1}{3}\right)}$$

M1A1

Note: Award **M1** for recognizing conditional probability, **A1** for correct substitution.

OR

$$\frac{\frac{1}{2}}{1 - \frac{1}{3}}$$

M1A1

Note: Award **M1** for recognizing conditional probability, **A1** for correct substitution.

THEN

$$= \frac{3}{4}$$

A1

[3 marks]
[Total 7 marks]

8. (a) $z = 2e^{-0.524i} \left(= 2e^{-\frac{\pi i}{6}} \right)$

A1A1

Note: Award **A1** for the correct modulus and **A1** for the correct argument.

[2 marks]

(b) **METHOD 1**

$$z_1 + z_2 = e^{2it} \left(1 + 2e^{-\frac{\pi i}{6}} \right)$$

(M1)

$$= e^{2it} \times 2.90931...e^{-0.350879...i}$$

(A1)

$$\text{Im}(z_1 + z_2) = 2.91 \sin(2t - 0.351)$$

A1A1

METHOD 2

attempt to find the modulus of $\left(1 + 2e^{-\frac{\pi i}{6}} \right)$

(M1)

$$p = \left| 1 + 2e^{-\frac{\pi i}{6}} \right|$$

attempt to find the argument of $\left(1 + 2e^{-\frac{\pi i}{6}} \right)$

(M1)

$$q = \arg \left(1 + 2e^{-\frac{\pi i}{6}} \right)$$

$$\text{Im}(z_1 + z_2) = 2.91 \sin(2t - 0.351)$$

A1A1

METHOD 3

sketching $\text{Im}(z_1 + z_2)$

(M1)

max is (0.961, 2.91)

(A1)

first root is 0.1754

(A1)

$$\text{Im}(z_1 + z_2) = 2.91 \sin(2t - 0.351)$$

A1

[4 marks]

[Total 6 marks]

9. (a) $p = 1.5; q = 2$ **A1A1**
[2 marks]
- (b) attempt at using chain rule **(M1)**
- (i) $h'(t) = -\frac{\pi}{4} \sin\left(\frac{\pi}{6}t\right) \left(= -0.785 \sin\left(\frac{\pi}{6}t\right) \right)$ **A1**
- (ii) $h''(t) = -\frac{\pi^2}{24} \cos\left(\frac{\pi}{6}t\right) \left(= -0.411233\dots \cos\left(\frac{\pi}{6}t\right) \right)$ **A1**
[3 marks]
- (c) (i) attempt to locate points of inflexion or max value of $h'(t)$ **(M1)**
- $h''(t) = -\frac{\pi^2}{24} \cos\left(\frac{\pi}{6}t\right) = 0$ **OR** sketch on graph **OR** $t = 3$ **OR** $\frac{\pi}{6}k = \frac{3\pi}{2}$
 $(k =) 9$ **A1**
- (ii) $(h(9) =) 2$ (m) **A1**
[3 marks]
[Total 8 marks]

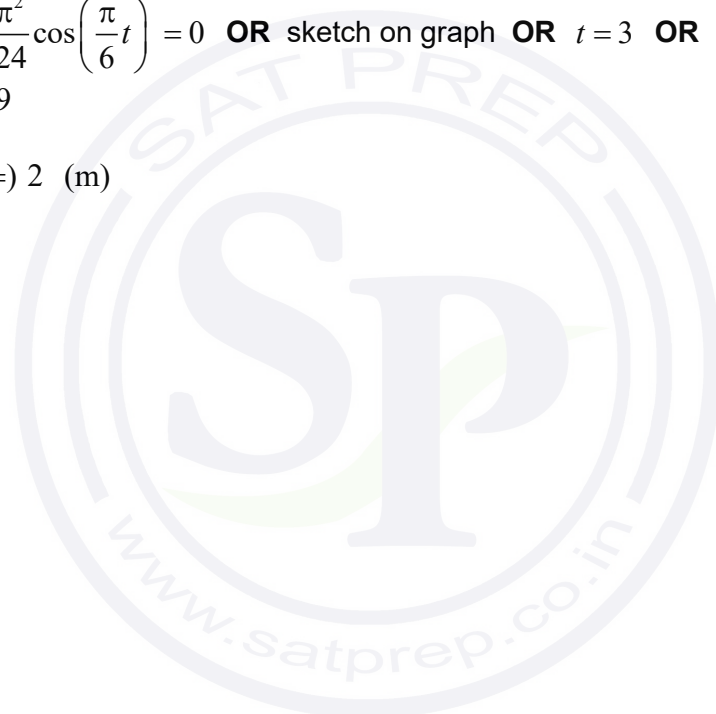

10. (a) $M = 1000 \times t^{-0.6}$
 $a = 1000 (= 999.972\dots)$ $b = -0.600 (-0.599991\dots)$ **A1A1**

[2 marks]

(b) $y = -0.600x + 6.908$
 $c = -0.600$ $d = 6.908$ **A1A1**

Note: Long answer for c is 0.599991... and for d is 6.90772... If both answers are correct but not given to 3 decimal places award **A1A0**.

[2 marks]

(c) **METHOD 1 (starting with the result in part (b))**
 attempt to apply addition (or subtraction) log laws **M1**
 attempt to apply inverse log **M1**

Note: These **M1** marks can be applied in either order depending on the approach.

e.g. $\ln M = \ln t^{-0.600} + \ln e^{6.908}$ then $\ln M = \ln(e^{6.908} \times t^{-0.600})$

OR $\ln \frac{M}{t^{-0.600}} = 6.908$ then $\frac{M}{t^{-0.600}} = e^{6.908}$

$M = e^{6.908} t^{-0.600}$ **A1**

$(M = 1000.24t^{-0.6})$

$M = 1000t^{-0.6}$ and hence (close enough to be) equivalent **AG**

Note: The **AG** line (or something which approximates it) must be seen for the final **A1** to be awarded. If 3 sf answers are used from part (b), the coefficient is 1002; this can be condoned in the working, as it equals 1000 when rounded to 3 sf.

METHOD 2 (starting with the result in part (a))
 attempt to apply log **M1**

$\ln M = \ln(1000 \times t^{-0.6})$

attempt to apply addition (or subtraction) log laws **M1**

$\ln M = \ln 1000 + \ln t^{-0.6}$

$\ln M = 6.90775\dots - 0.6 \ln t$ **A1**

$(\ln M = y, \ln t = x)$

$y = -0.600x + 6.908$ and hence (close enough to be) equivalent **AG**

Note: The **AG** line (or something which approximates it) must be seen for the final **A1** to be awarded. Condone $b = -0.6$.

[3 marks]

[Total 7 marks]

11. (a) (i) **EITHER**

(area of $R = \int_{-1}^1 |x^3 - x| dx$ **A1**

OR

(area of $R = 2 \times \int_{-1}^0 x^3 - x dx$ **OR** (area of $R = -2 \times \int_0^1 x^3 - x dx$ **A1**

OR

(area of $R = \int_{-1}^0 x^3 - x dx - \int_0^1 x^3 - x dx$ **A1**

(ii) (area of $R = 0.5$ **A1**

Note: Follow through from part (a)(i) only if answer is greater than zero.

[2 marks]

(b)

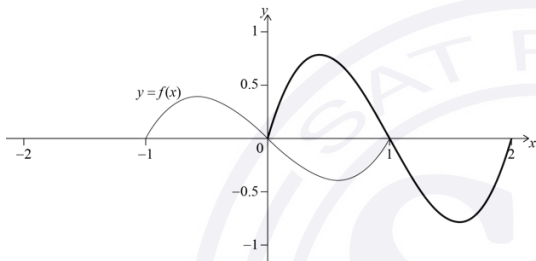

A1A1

Note: Award **A1** for sketch with correct shape on $[0, 2]$, **A1** for vertical stretch $\times 2$. Condone max/min of g extending to $1 / -1$.

[2 marks]

(c) attempt to use $\pi \int y^2 dx$ **(M1)**

volume $= \pi \int_{-1}^1 (x^3 - x)^2 dx$ **(A1)**

volume $= 0.479$ (cubic units) $\left(= 0.478718\dots, \frac{16\pi}{105} \right)$ **A1**

[3 marks]
[Total 7 marks]

12. (a) gradient $(= -3+1+1) = -1$
 $y+1 = -1(x+1)$
 $x+y+2 = 0$

A1

A1

[2 marks]

(b)

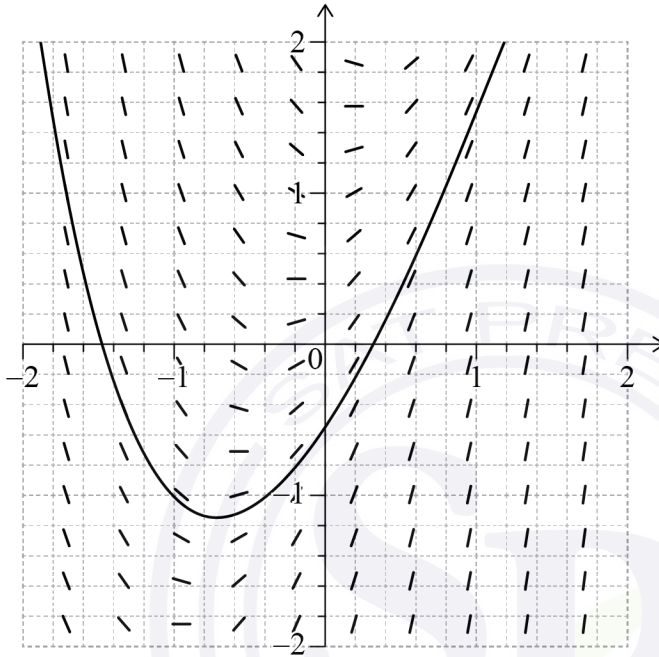

A1A1

Note: Award **A1** for (approximately) intersecting $(-1, -1)$ and with correct gradient, **A1** for generally plausible shape (e.g. not crossing over LOTS of isoclines).

[2 marks]
[Total 4 marks]

13. (a) attempt to solve $u_1(t) = u_2(t)$ **OR** sketch of two graphs **(M1)**
A1
($T =$) 2

Note: Award **(M1)A0** if additional values of T are seen **OR** if $T = -2$ is their final answer.

[2 marks]

- (b) $u_1'(t) = 4t - 3t^2$ **A1**
 $u_1'(2) = -4 = u_2'(2)$ **R1**

[2 marks]

(c)

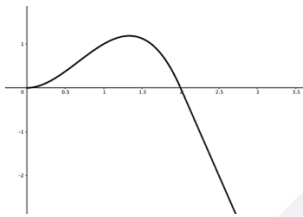

recognition of integrating **AND** equating to zero **(M1)**

$$\int_0^2 2t^2 - t^3 dt + \int_2^k 8 - 4t dt = 0$$
 (A1)

$$\frac{4}{3} + (8k - 2k^2) - 8 = 0 \quad \text{OR} \quad 1.18350\dots \left(\frac{6 - \sqrt{6}}{3} \right) \text{ seen}$$
 (A1)

Note: Award **(M1)(A1)A0** if integration done correctly but limits are not substituted.

($k =$) 2.82 $\left(= 2.81649\dots, \frac{6 + \sqrt{6}}{3} \right)$ **A1**

[4 marks]
[Total 8 marks]

14. (a) vector from Q to any point in L or vice versa

$$= \begin{pmatrix} 1+\lambda \\ 3+\lambda \\ 2\lambda \end{pmatrix} - \begin{pmatrix} 11 \\ -1 \\ 3 \end{pmatrix} = \begin{pmatrix} -10+\lambda \\ 4+\lambda \\ 2\lambda-3 \end{pmatrix} \quad (M1)$$

EITHER (scalar product)
 attempt to use scalar product (M1)

$$\begin{pmatrix} -10+\lambda \\ 4+\lambda \\ 2\lambda-3 \end{pmatrix} \cdot \begin{pmatrix} 1 \\ 1 \\ 2 \end{pmatrix} = 0$$

$$-10 + \lambda + 4 + \lambda + 4\lambda - 6 = 0$$

OR (distance formula)
 attempt to use distance formula (M1)
 minimizing $(-10 + \lambda)^2 + (4 + \lambda)^2 + (-3 + 2\lambda)^2$

THEN
 $\lambda = 2$ (A1)

point $P(3, 5, 4)$ A1

Note: Do not award final **A1** for P given as a vector.

[4 marks]

(b) $\vec{PQ} = \begin{pmatrix} 8 \\ -6 \\ -1 \end{pmatrix}$ (A1)

attempt to use vector product (M1)

(perpendicular vector =) $\begin{pmatrix} 8 \\ -6 \\ -1 \end{pmatrix} \times \begin{pmatrix} 1 \\ 1 \\ 2 \end{pmatrix}$

$$\begin{pmatrix} -11 \\ -17 \\ 14 \end{pmatrix} \quad \text{A1}$$

Note: Award final **A1** for any multiple (positive or negative) of the answer given here.

[3 marks]
 [Total 7 marks]

15. (a) probability of non veg remaining non veg **A1**
[1 mark]

(b) attempt to use $\det(A - \lambda I) = 0$ **(M1)**

$$\begin{vmatrix} 0.8 - \lambda & 0.1 \\ 0.2 & 0.9 - \lambda \end{vmatrix} = 0$$

$$(0.8 - \lambda)(0.9 - \lambda) - 0.1 \times 0.2 = 0$$
 (A1)

$$\lambda = 1; \lambda = 0.7$$
 A1

[3 marks]

(c) $-2a + b = 0$ **M1**

$$v_1 = \begin{pmatrix} 1 \\ 2 \end{pmatrix} \text{ (accept any multiples of this answer)}$$
 A1

v_1 means that in the long term the ratio of veg to non-veg is 1:2

(in the long term one-third of students will be veg and two-thirds will not) **A1**

[3 marks]

[Total 7 marks]

16. (a) Let X be the random variable number of shots taken in a 12 minute period
 $X \sim \text{Po}(5)$ **(A1)**

$$P(X \leq 6) = 0.762 \text{ (= 0.762183...)} \quad \text{A1}$$

[2 marks]

(b) $P(\text{less than 4 shots} \cap \text{success at least once})$

METHOD 1

$$= P(\text{less than 4 shots}) - P(\text{less than 4 shots} \cap \text{zero success})$$
 (M1)

Note: Might be communicated in Venn diagram.

attempt to multiply by different powers of 0.6 **(M1)**

$$= P(X \leq 3) - (P(X = 0) \times (0.6)^0 + P(X = 1) \times (0.6)^1 + P(X = 2) \times (0.6)^2 + P(X = 3) \times (0.6)^3)$$

$$= 0.414 \text{ (= 0.413845...)} \quad \text{A1}$$

$$= 0.414 \text{ (= 0.413845...)} \quad \text{A1}$$

METHOD 2

attempt to multiply by different powers of 0.4 **(M1)**

$$= P(X = 1) \times (0.4)^1 + P(X = 2) \times ((0.4)^2 + 2 \times 0.4 \times 0.6) + P(X = 3) \times ((0.4)^3 + 3 \times 0.4^2 \times 0.6 + 3 \times 0.4 \times 0.6^2)$$

(M1)(A1)

Note: Award **M1** for recognizing the six different cases, e.g. $2 \times 0.4 \times 0.6$ (etc.) or equivalent seen, **A1** for completely correct expression.

$$= 0.414 \text{ (= 0.413845...)} \quad \text{A1}$$

[4 marks]

[Total 6 marks]

Markscheme

May 2023

**Mathematics:
applications and interpretation**

Higher level

Paper 1

© International Baccalaureate Organization 2023

All rights reserved. No part of this product may be reproduced in any form or by any electronic or mechanical means, including information storage and retrieval systems, without the prior written permission from the IB. Additionally, the license tied with this product prohibits use of any selected files or extracts from this product. Use by third parties, including but not limited to publishers, private teachers, tutoring or study services, preparatory schools, vendors operating curriculum mapping services or teacher resource digital platforms and app developers, whether fee-covered or not, is prohibited and is a criminal offense.

More information on how to request written permission in the form of a license can be obtained from <https://ibo.org/become-an-ib-school/ib-publishing/licensing/applying-for-a-license/>.

© Organisation du Baccalauréat International 2023

Tous droits réservés. Aucune partie de ce produit ne peut être reproduite sous quelque forme ni par quelque moyen que ce soit, électronique ou mécanique, y compris des systèmes de stockage et de récupération d'informations, sans l'autorisation écrite préalable de l'IB. De plus, la licence associée à ce produit interdit toute utilisation de tout fichier ou extrait sélectionné dans ce produit. L'utilisation par des tiers, y compris, sans toutefois s'y limiter, des éditeurs, des professeurs particuliers, des services de tutorat ou d'aide aux études, des établissements de préparation à l'enseignement supérieur, des fournisseurs de services de planification des programmes d'études, des gestionnaires de plateformes pédagogiques en ligne, et des développeurs d'applications, moyennant paiement ou non, est interdite et constitue une infraction pénale.

Pour plus d'informations sur la procédure à suivre pour obtenir une autorisation écrite sous la forme d'une licence, rendez-vous à l'adresse <https://ibo.org/become-an-ib-school/ib-publishing/licensing/applying-for-a-license/>.

© Organización del Bachillerato Internacional, 2023

Todos los derechos reservados. No se podrá reproducir ninguna parte de este producto de ninguna forma ni por ningún medio electrónico o mecánico, incluidos los sistemas de almacenamiento y recuperación de información, sin la previa autorización por escrito del IB. Además, la licencia vinculada a este producto prohíbe el uso de todo archivo o fragmento seleccionado de este producto. El uso por parte de terceros —lo que incluye, a título enunciativo, editoriales, profesores particulares, servicios de apoyo académico o ayuda para el estudio, colegios preparatorios, desarrolladores de aplicaciones y entidades que presten servicios de planificación curricular u ofrezcan recursos para docentes mediante plataformas digitales—, ya sea incluido en tasas o no, está prohibido y constituye un delito.

En este enlace encontrará más información sobre cómo solicitar una autorización por escrito en forma de licencia: <https://ibo.org/become-an-ib-school/ib-publishing/licensing/applying-for-a-license/>.

Instructions to Examiners

Abbreviations

- M** Marks awarded for attempting to use a correct **Method**.
- A** Marks awarded for an **Answer** or for **Accuracy**; often dependent on preceding **M** marks.
- R** Marks awarded for clear **Reasoning**.
- AG** Answer given in the question and so no marks are awarded.
- FT** Follow through. The practice of awarding marks, despite candidate errors in previous parts, for their correct methods/answers using incorrect results.

Using the markscheme

1 General

Award marks using the annotations as noted in the markscheme eg **M1**, **A2**.

2 Method and Answer/Accuracy marks

- Do **not** automatically award full marks for a correct answer; all working **must** be checked, and marks awarded according to the markscheme.
- It is generally not possible to award **M0** followed by **A1**, as **A** mark(s) depend on the preceding **M** mark(s), if any.
- Where **M** and **A** marks are noted on the same line, e.g. **M1A1**, this usually means **M1** for an **attempt** to use an appropriate method (e.g. substitution into a formula) and **A1** for using the **correct** values.
- Where there are two or more **A** marks on the same line, they may be awarded independently; so if the first value is incorrect, but the next two are correct, award **A0A1A1**.
- Where the markscheme specifies **A3**, **M2** etc., do **not** split the marks, unless there is a note.
- The response to a “show that” question does not need to restate the **AG** line, unless a **Note** makes this explicit in the markscheme.
- Once a correct answer to a question or part question is seen, ignore further working even if this working is incorrect and/or suggests a misunderstanding of the question. This will encourage a uniform approach to marking, with less examiner discretion. Although some candidates may be advantaged for that specific question item, it is likely that these candidates will lose marks elsewhere too.
- An exception to the previous rule is when an incorrect answer from further working is used **in a subsequent part**. For example, when a correct exact value is followed by an incorrect decimal approximation in the first part and this approximation is then used in the second part. In this situation, award **FT** marks as appropriate but do not award the final **A1** in the first part. Examples:

	Correct answer seen	Further working seen	Any FT issues?	Action
1.	$8\sqrt{2}$	5.65685... (incorrect decimal value)	No. Last part in question.	Award A1 for the final mark (condone the incorrect further working)
2.	$\frac{35}{72}$	0.468111... (incorrect decimal value)	Yes. Value is used in subsequent parts.	Award A0 for the final mark (and full FT is available in subsequent parts)

3 Implied marks

Implied marks appear in **brackets e.g. (M1)**, and can only be awarded if **correct** work is seen or implied by subsequent working/answer.

4 Follow through marks (only applied after an error is made)

Follow through (**FT**) marks are awarded where an incorrect answer from one **part** of a question is used correctly in **subsequent** part(s) (e.g. incorrect value from part (a) used in part (d) or incorrect value from part (c)(i) used in part (c)(ii)). Usually, to award **FT** marks, **there must be working present** and not just a final answer based on an incorrect answer to a previous part. However, if all the marks awarded in a subsequent part are for the answer or are implied, then **FT** marks should be awarded for *their* correct answer, even when working is not present.

For example: following an incorrect answer to part (a) that is used in subsequent parts, where the markscheme for the subsequent part is **(M1)A1**, it is possible to award full marks for *their* correct answer, **without working being seen**. For longer questions where all but the answer marks are implied this rule applies but may be overwritten by a **Note** in the Markscheme.

- Within a question part, once an **error** is made, no further **A** marks can be awarded for work which uses the error, but **M** marks may be awarded if appropriate.
- If the question becomes much simpler because of an error then use discretion to award fewer **FT** marks, by reflecting on what each mark is for and how that maps to the simplified version.
- If the error leads to an inappropriate value (e.g. probability greater than 1, $\sin \theta = 1.5$, non-integer value where integer required), do not award the mark(s) for the final answer(s).
- The markscheme may use the word “their” in a description, to indicate that candidates may be using an incorrect value.
- If the candidate’s answer to the initial question clearly contradicts information given in the question, it is not appropriate to award any **FT** marks in the subsequent parts. This includes when candidates fail to complete a “show that” question correctly, and then in subsequent parts use their incorrect answer rather than the given value.
- Exceptions to these **FT** rules will be explicitly noted on the markscheme.
- If a candidate makes an error in one part but gets the correct answer(s) to subsequent part(s), award marks as appropriate, unless the command term was “Hence”.

5 Mis-read

If a candidate incorrectly copies values or information from the question, this is a mis-read (**MR**). A candidate should be penalized only once for a particular misread. Use the **MR** stamp to indicate that this has been a misread and do not award the first mark, even if this is an **M** mark, but award all others as appropriate.

- If the question becomes much simpler because of the **MR**, then use discretion to award fewer marks.
- If the **MR** leads to an inappropriate value (e.g. probability greater than 1, $\sin \theta = 1.5$, non-integer value where integer required), do not award the mark(s) for the final answer(s).
- Miscopying of candidates' own work does **not** constitute a misread, it is an error.
- If a candidate uses a correct answer, to a "show that" question, to a higher degree of accuracy than given in the question, this is NOT a misread and full marks may be scored in the subsequent part.
- **MR** can only be applied when work is seen. For calculator questions with no working and incorrect answers, examiners should **not** infer that values were read incorrectly.

6 Alternative methods

Candidates will sometimes use methods other than those in the markscheme. Unless the question specifies a method, other correct methods should be marked in line with the markscheme. If the command term is 'Hence' and not 'Hence or otherwise' then alternative methods are not permitted unless covered by a note in the mark scheme.

- Alternative methods for complete questions are indicated by **METHOD 1**, **METHOD 2**, etc.
- Alternative solutions for parts of questions are indicated by **EITHER . . . OR**.

7 Alternative forms

Unless the question specifies otherwise, **accept** equivalent forms.

- As this is an international examination, accept all alternative forms of **notation** for example 1.9 and 1,9 or 1000 and 1,000 and 1.000.
- Do not accept final answers written using calculator notation. However, **M** marks and intermediate **A** marks can be scored, when presented using calculator notation, provided the evidence clearly reflects the demand of the mark.
- In the markscheme, equivalent **numerical** and **algebraic** forms will generally be written in brackets immediately following the answer.
- In the markscheme, some **equivalent** answers will generally appear in brackets. Not all equivalent notations/answers/methods will be presented in the markscheme and examiners are asked to apply appropriate discretion to judge if the candidate work is equivalent.

8 Format and accuracy of answers

If the level of accuracy is specified in the question, a mark will be linked to giving the answer to the required accuracy. If the level of accuracy is not stated in the question, the general rule applies to final answers: *unless otherwise stated in the question all numerical answers must be given exactly or correct to three significant figures.*

Where values are used in subsequent parts, the markscheme will generally use the exact value, however candidates may also use the correct answer to a “correct” level of accuracy (e.g 3 sf) in subsequent parts. The markscheme will often explicitly include the subsequent values that come “*from the use of 3 sf values*”.

Simplification of final answers: Candidates are advised to give final answers using good mathematical form. In general, for an **A** mark to be awarded, arithmetic should be completed, and

any values that lead to integers should be simplified; for example, $\sqrt{\frac{25}{4}}$ should be written as $\frac{5}{2}$.

An exception to this is simplifying fractions, where lowest form is not required (although the numerator and the denominator must be integers); for example, $\frac{10}{4}$ may be left in this form or

written as $\frac{5}{2}$. However, $\frac{10}{5}$ should be written as 2, as it simplifies to an integer.

Algebraic expressions should be simplified by completing any operations such as addition and multiplication, e.g. $4e^{2x} \times e^{3x}$ should be simplified to $4e^{5x}$, and $4e^{2x} \times e^{3x} - e^{4x} \times e^x$ should be simplified to $3e^{5x}$. Unless specified in the question, expressions do not need to be factorized, nor do factorized expressions need to be expanded, so $x(x+1)$ and $x^2 + x$ are both acceptable.

Please note: intermediate **A** marks do NOT need to be simplified.

9 Calculators

A GDC is required for this paper, but If you see work that suggests a candidate has used any calculator not approved for IB DP examinations (eg CAS enabled devices), please follow the procedures for malpractice.

10. Presentation of candidate work

Crossed out work: If a candidate has drawn a line through work on their examination script, or in some other way crossed out their work, do not award any marks for that work unless an explicit note from the candidate indicates that they would like the work to be marked.

More than one solution: Where a candidate offers two or more different answers to the same question, an examiner should only mark the first response unless the candidate indicates otherwise. If the layout of the responses makes it difficult to judge, examiners should apply appropriate discretion to judge which is “first”.



1. (a) **METHOD 1**
correct sketch with some indication of maximum point

(M1)

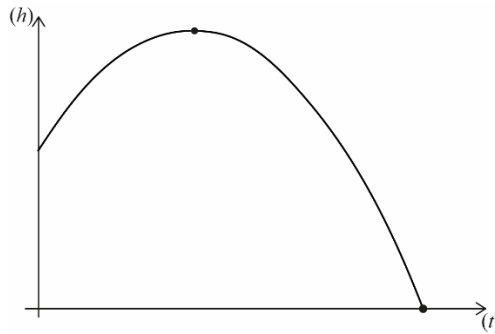

0.921 (seconds) $\left(0.921052\dots, \frac{35}{38} \right)$

A1

- METHOD 2**
correct substitution into equation for line of symmetry

(M1)

$$(t =) -\frac{8.75}{2 \times -4.75}$$

0.921 (seconds) $\left(0.921052\dots, \frac{35}{38} \right)$

A1

- METHOD 3**
equating the correct derivative to 0
 $-9.5t + 8.75 = 0$

(M1)

0.921 (seconds) $\left(0.921052\dots, \frac{35}{38} \right)$

A1

Note: Award **M1A0** for a final answer of 0.92 seen with no working.

[2 marks]

- (b) **METHOD 1**
correct sketch with some indication of x-intercept

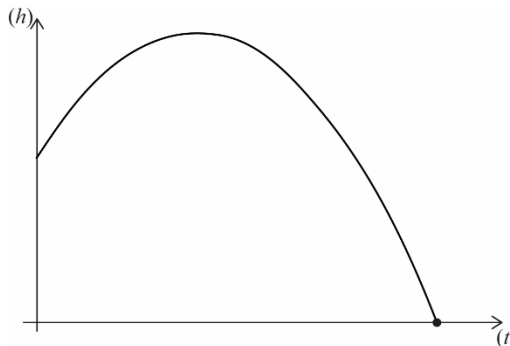

(M1)

Note: May be seen in part (a).

2 (seconds)

A1

continued...

Question 1 continued

METHOD 2

setting the equation to zero

(M1)

$$-4.75t^2 + 8.75t + 1.5 = 0$$

2 (seconds)

A1

Note: If both roots are given, with or without working, award **(M1)A0**.

[2 marks]

(c) **METHOD 1**

correct sketch of quadratic function and a straight line in approximate correct position

(M1)

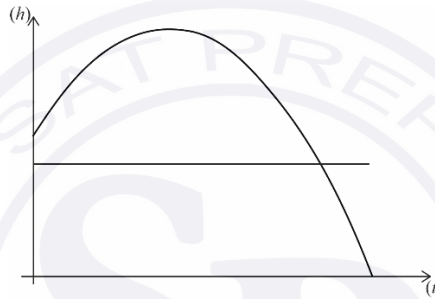

1.88 (seconds) (1.87577...(seconds))

A1

METHOD 2

setting the equation equal to 1.2

(M1)

$$-4.75t^2 + 8.75t + 1.5 = 1.2$$

1.88 (seconds) (1.87577...(seconds))

A1

Note: Award **(M1)A0** if -0.0336702... seen as (part of) a final answer.
Award **M1A0** for answer of 1.9 seen without working.

[2 marks]

(d) Award **R1** for a sensible reason in the context of the question:

R1

e.g.

The model ignores air resistance (or wind)

The model treats the ball as a point

The model assumes gravity is constant

The model assumes that the ball continues to follow the trajectory even after hitting the ground

This model ignores the bouncing back of the ball after hitting the ground

Note: Do not accept generic criticisms of any mathematical model, such as:
There are assumptions being made
Models are never accurate / It is only a model

[1 mark]

Total [7 marks]

2. (a) 11.0 (11.0212...) **A2**

Note: Award **A1** for a final answer of 11 if no unrounded answer is seen.

[2 marks]

(b) **EITHER**
 11.0 > 9.488 (11.0212... > 9.488) **R1**

OR
 0.0263 < 0.05 (0.0263264... < 0.05) **R1**

THEN

EITHER
 (there is significant evidence to) reject H_0 **A1**

OR
 (there is significant evidence that) the (food) quality and the type of meal are not independent **A1**

Note: Do not award **ROA1**.

Award **R1** for $\chi^2_{\text{calc}} > \chi^2_{\text{crit}}$, provided the calculated value is explicitly seen in part (b).

Accept “ p -value < significance level” provided their p -value is seen and their p -value is between 0 and 1.

[2 marks]

Total [4 marks]

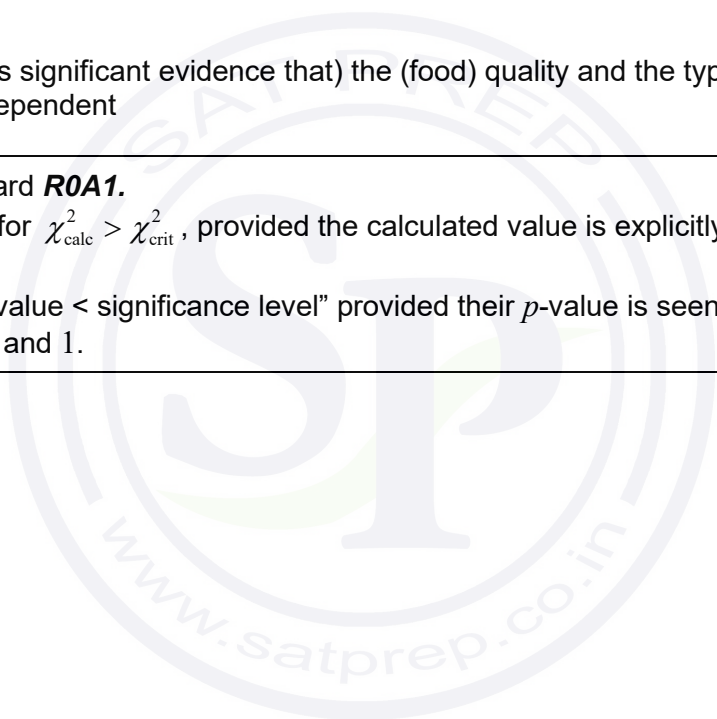

3. (a) attempting to use $P(R \cap S) = P(R)P(S)$ (M1)
 $0.2 = 0.8(0.2 + x)$ (A1)
 $x = 0.05$ A1
[3 marks]

(b) $x + 0.2 + 0.6 + y = 1$ (M1)
 $y = 0.15$ A1
[2 marks]

(c) **METHOD 1**
attempting to apply $P(R' | S') = \frac{P(R' \cap S')}{P(S')}$ (M1)
 $\frac{0.15}{0.2}$
 $= \frac{3}{4}$ A1

METHOD 2
 $P(R' | S') = P(R')$ (because R, S are independent) (M1)
 $= 1 - 0.25 = 0.75$ A1

Note: FT from their values of x or y .

[2 marks]
Total [7 marks]

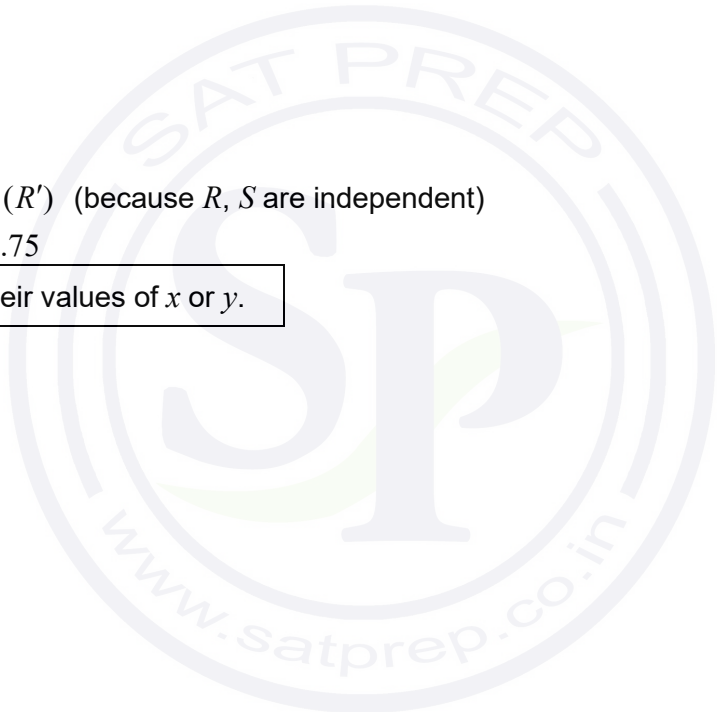

4. (a) **METHOD 1 (use of financial app in GDC)**

$N = 5$	OR	$N = 20$
$I\% = 1.2$		$I\% = 1.2$
$PV = \pm 520$		$PV = \pm 520$
$P/Y = 1$		$P/Y = 4$
$C/Y = 4$		$C/Y = 4$

(M1)(A1)

Note: Award **M1** for evidence of using the financial app on the calculator, **A1** for all correct entries.

(\$) 552.11

A1

Note: Award at most **(M1)(A1)A0** if correct answer is not given to two decimal places.

METHOD 2 (use of formula)

attempt to substitute into compound interest formula

(M1)

$$520 \times \left(1 + \frac{1.2}{100 \times 4} \right)^{5 \times 4}$$

(A1)

(\$) 552.11

A1

Note: Award at most **(M1)(A1)A0** if correct answer is not given to two decimal places.

[3 marks]

(b) **EITHER**

$N = 5$
 $I\% = 43.5$ (43.4772...(%))
 $PV = \pm 520$
 $FV = \mp 30$

(M1)(A1)A1

Note: Award **M1** for evidence of using the finance app on the calculator, **A1** for all correct entries, **A1** for correct final answer. Condone missing -/+ sign if the correct final answer is seen.

OR

$$30 = 520 \left(1 - \frac{r}{100} \right)^5 \quad (\text{or equivalent})$$

(M1)(A1)

$(r =) 43.5\%$ (43.477...%)

A1

Note: Award **M1** for using the compound interest formula, **A1** for correct substitutions and for equating to 30, **A1** for correct final answer. Accept $(r =) -43.5\%$. Award **M1A1A0** for a final answer of 56.5%.

[3 marks]

Total [6 marks]

5. (a) $X \sim N(4, 0.25^2)$

EITHER

correct probability expression

(M1)

$P(X < 3.7)$

Note: Accept a weak or strict inequality, and any label instead of X , e.g. length or L .

OR

normal curve with vertical line, left of mean, labelled 3.7, and shaded region **(M1)**

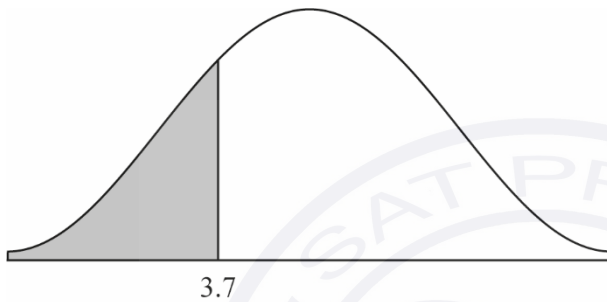

THEN

0.115 (0.115069..., 11.5%)

A1

Note: Award **M1A0** for 0.12 if no previous working.

[2 marks]

(b) **EITHER**

Correct probability expression

(M1)

$(P(X < k) = 0.7 \text{ OR } P(X > k) = 0.3)$

Note: Accept a weak or strict inequality, and any label instead of X e.g., length or L .

continued...

Question 5 continued

OR

normal curve with vertical line to the right of the mean and shaded region, correctly labelled either 0.3 or 0.7

(M1)

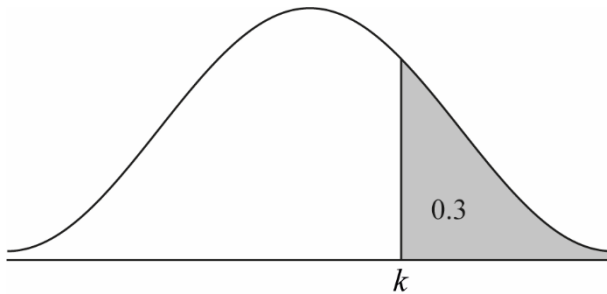

THEN

$(k =) 4.13 (4.13110\dots)$

A1

Note: Award **M1A0** for 4.1 if no previous working.

[2 marks]

(c) **EITHER**

correct probability equation

$P(\text{length} < 4 + m) = 0.8$ **OR** $P(\text{length} < 4 - m) = 0.2$

(M1)

Note: Accept any letter instead of "length" e.g., X or L .

OR

normal curve with vertical lines symmetrical about the mean line with a correct indication of an area of 0.6 or 0.2 or 0.8

(M1)

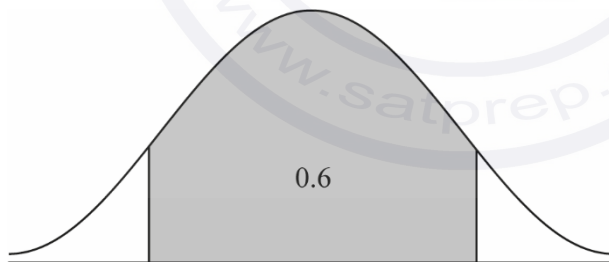

THEN

0.210 (0.210405...)

A1

Note: Award **(M1)A0** for an answer of 3.7895 or 4.2105 seen without working. Condone 0.21 seen and award **(M1)A1**.

[2 marks]

Total [6 marks]

6. (a) **EITHER**
 $\frac{4}{3}\pi(3.4)^3$ (A1)

Multiplying their volume by $\frac{4}{5}$ (M1)

OR
 $\frac{4}{3}\pi(3.4)^3$ (A1)

Subtracting $\frac{1}{5}$ of their volume (M1)

$$\left(\frac{4}{3}\pi(3.4)^3 - \frac{1}{5} \times \frac{4}{3}\pi(3.4)^3\right)$$

Note: The **M1** can be awarded for a final answer of 32.9272... seen without working.

THEN
 132 cm³ (131.708... cm³) A1
 [3 marks]

(b) $\pi \times 3 \times 11$ (A1)

103.672... (cm²) **OR** 33π (cm²)
 104 (cm²) A1
 [2 marks]
Total [5 marks]

7. (a) $(56 \times 0.86) = 48.2$ (48.16) A1

Note: Accept 48.

[1 mark]

(b) recognizing binomial distribution (may be seen in (a)) (M1)
 e.g. $X \sim B(56, 0.86)$

$(P(X \geq 50) =) 0.316$ A2
 [3 marks]

(c) $P(X \leq n) \geq 0.25$
 $n = 46$ A2
 [2 marks]
Total [6 marks]

8. (a) attempt to create a 5x5 adjacency matrix (M1)

$$M = \begin{pmatrix} 0 & 0 & 1 & 0 & 1 \\ 0 & 0 & 1 & 1 & 0 \\ 0 & 1 & 0 & 0 & 1 \\ 1 & 0 & 1 & 0 & 0 \\ 0 & 0 & 0 & 1 & 0 \end{pmatrix} \quad \text{A2}$$

Note: Allow the transposed matrix. Award **A2** for all entries correct, **A1** if one or two entries are incorrect, **A0** otherwise.
 Answer presented in markscheme assumes ABCDE ordering of rows and columns; accept other orders provided they are clearly communicated.
 Award **A1** if the zeroes are replaced by blank cells.

[3 marks]

- (b) (i) recognizing need to find M^7 (M1)

$$M^7 = \begin{pmatrix} 8 & 8 & 17 & 8 & 13 \\ 8 & 10 & 19 & 17 & 14 \\ 6 & 11 & 16 & 10 & 17 \\ 11 & 8 & 19 & 14 & 10 \\ 2 & 6 & 8 & 11 & 8 \end{pmatrix}$$

2 (routes) A1

- (ii) vertices visited in order are
EITHER
 $E \rightarrow D \rightarrow C \rightarrow B \rightarrow C \rightarrow B \rightarrow D \rightarrow A$ A2

OR
 $E \rightarrow D \rightarrow C \rightarrow B \rightarrow C \rightarrow E \rightarrow D \rightarrow A$ A2

[4 marks]

Total [7 marks]

9. (a)

Athlete	A	B	C	D	E	F	G	H
Age rank	7	6	3	5	4	2	8	1
Time rank	3.5	2	3.5	6	7	8	1	5

A1A1

Note: Award **A1** for each correct row.

[2 marks]

(b) $r_s = -0.671$ ($-0.670670\dots$)

A2

Note: Only follow through from an incorrect table provided the ranks are all between 1 and 8.
Award **A1** for -0.67 **OR** for the omission of the negative sign, e.g. 0.671 ($0.670670\dots$) or 0.67

[2 marks]

(c) (A value of $r_s = -0.671$) indicates a negative correlation between a person's age and the best time they take to run 100m.

R1

Note: Condone any comment that includes "weak" or "strong" etc. Accept an interpretation in words, but only if there is a general link described and not a rule: "The older a person gets, the faster they *tend to* run".
Answer must be in context.

[1 mark]

(d) Award **R1** for any sensible reason:

R1

The correlation, such that it is, is unlikely to be linear for this type of data.
Spearman's CC is less sensitive to outliers
Sung-Jin is not sure the data is drawn from a bivariate normal distribution
There are outliers/extreme data
Same time for two athletes with significantly different ages

[1 mark]

(e) (i) 0.264 ($0.263762\dots$)

A2

Note: Award **A1** for 0.26 with no working. Given that the exact model is not specific in the question, accept correct r^2 values from other regression models: 0.631 , 0.650 , 0.759 and 0.256 .

(ii) approximately 26% of the variability in the times taken can be explained by the runner's age.

R1

[3 marks]

Total [9 marks]

10. (a) H_0 : there is no particular preference for any of the flavours A1
 H_1 : there is a particular preference for some of the flavours A1

Note: Accept equivalent statements such as " H_0 : the population ratio of flavour preferences is 1:1:1:1" or " H_0 : the population proportions are equal for each flavour" or " H_0 : the data is drawn from a uniform distribution".

[2 marks]

- (b) **EITHER**
 p -value = 0.0629 (0.0629034...) A2
 $0.0629 > 0.05$ R1
OR
 $\chi^2_{\text{calc}} = 7.30$ A2
 $7.30 < 7.82$ R1

Note: Award **A2** for either p -value = 0.063 or $\chi^2_{\text{calc}} = 7.3$ seen. Award **R1** for a correct comparison involve their p -value or χ^2_{calc} , and follow through for their conclusion.

THEN
so there is insufficient evidence to reject H_0 , i.e.
there is no particular preference for any of the flavours. A1

Note: Do not award **R0A1**.

[4 marks]
Total [6 marks]

11. (a) $30 \sin(t + 60^\circ) + 60 \sin(t + 10^\circ)$ (M1)
finding maximum graphically
82.5 (V) (82.5471...) A1

Note: Award **M1A0** for 83.

[2 marks]

- (b) recognizing that a is still 1 A1
 $V_0 = 82.5$ A1
attempt to find an x -intercept of combined voltage (M1)
 $b = 26.2^\circ$ (26.1643... $^\circ$) **OR** any other correct x -intercept A1

Note: May be seen in the final answer. Award **M1A0** for $b = 26$ with no working.

$$(V_{\text{TOT}} = 82.5 \sin(t + 26.2^\circ) (82.5471... \sin(t + 26.1643...^\circ)))$$

Note: Award at most **(M1)A1(A1)A0** if phase shift of -153.835... is seen in the final answer. In part (b), candidates may use $\arg(30e^{60i} + 60e^{10i})$ to determine the new phase shift, and hence could be awarded **M1** for this valid method.

[4 marks]
Total [6 marks]

12. (a) equating volume of sphere formula to 288π

(M1)

$$\frac{4}{3}\pi r^3 = 288\pi$$

$$\Rightarrow r = 6 \text{ (cm)}$$

A1

[2 marks]

(b) $\frac{dV}{dr} = 4\pi r^2$ (seen anywhere)

(A1)

$$\frac{dV}{dt} = \frac{dV}{dr} \frac{dr}{dt}$$

(M1)

$$\frac{dV}{dt} = 4\pi r^2 \frac{dr}{dt}$$

$$15 = 4\pi \times 6^2 \times \frac{dr}{dt}$$

$$\frac{dr}{dt} = \frac{15}{144\pi} \text{ (cm s}^{-1}\text{) (0.0332, 0.0331572...)}$$

A1

[3 marks]

Total [5 marks]



13. (a) **METHOD 1 (find product of matrices first)**

$$T \rightarrow T' \text{ is represented by } \mathbf{QP} = \begin{pmatrix} -4 & 1 \\ 1 & 3 \end{pmatrix} \begin{pmatrix} 3 & 1 \\ 0 & 2 \end{pmatrix} \quad (\mathbf{M1})$$

$$= \begin{pmatrix} -12 & -2 \\ 3 & 7 \end{pmatrix} \quad (\mathbf{A1})$$

recognizing need to find their $(\mathbf{QP})^{-1}$ (\mathbf{M1})

$$\begin{aligned} (\mathbf{QP})^{-1} &= \begin{pmatrix} -12 & -2 \\ 3 & 7 \end{pmatrix}^{-1} \\ &= -\frac{1}{78} \begin{pmatrix} 7 & 2 \\ -3 & -12 \end{pmatrix} \quad \text{OR} = \begin{pmatrix} -0.0897435\dots & -0.0256410\dots \\ 0.0384615\dots & 0.153846\dots \end{pmatrix} \quad \mathbf{A1} \end{aligned}$$

METHOD 2 (find inverses of both matrices first)

recognizing need to find inverse of both \mathbf{P} and \mathbf{Q} (\mathbf{M1})

$$\mathbf{P}^{-1} = \begin{pmatrix} \frac{1}{3} & -\frac{1}{6} \\ 0 & \frac{1}{2} \end{pmatrix} \quad \text{AND} \quad \mathbf{Q}^{-1} = \begin{pmatrix} -\frac{3}{13} & \frac{1}{13} \\ \frac{1}{13} & \frac{4}{13} \end{pmatrix} \quad (\mathbf{A1})$$

$$T' \rightarrow T \text{ is represented by } \mathbf{P}^{-1}\mathbf{Q}^{-1} = \begin{pmatrix} 3 & 1 \\ 0 & 2 \end{pmatrix}^{-1} \begin{pmatrix} -4 & 1 \\ 1 & 3 \end{pmatrix}^{-1} \quad (\mathbf{M1})$$

$$= -\frac{1}{78} \begin{pmatrix} 7 & 2 \\ -3 & -12 \end{pmatrix} \quad \text{OR} = \begin{pmatrix} -0.0897435\dots & -0.0256410\dots \\ 0.0384615\dots & 0.153846\dots \end{pmatrix} \quad \mathbf{A1}$$

Note: In METHOD 1, award **M1A0M1A0** if they multiply the matrices in the wrong order.
In METHOD 2, award **M1A1M1A0** if they multiply the matrices in the wrong order.

[4 marks]

$$(b) \left(\det \left[-\frac{1}{78} \begin{pmatrix} 7 & 2 \\ -3 & -12 \end{pmatrix} \right] \right) = -\frac{1}{78} \quad \text{OR} \quad \left(\det \begin{pmatrix} -12 & -2 \\ 3 & 7 \end{pmatrix} \right) = -78 \quad (\mathbf{A1})$$

$$\text{area of } T' = |\det \mathbf{QP}| \times \text{area of } T \quad \text{OR} \quad \text{area of } T = |\det (\mathbf{QP})^{-1}| \times \text{area of } T' \quad (\mathbf{M1})$$

$$\Rightarrow \text{area of } T = 273 \times \frac{1}{78}$$

$$= 3.5 \text{ (cm}^2\text{)} \quad \mathbf{A1}$$

Note: Award **(A1)(M0)A0** for an answer of $-3.5 \text{ (cm}^2\text{)}$ with or without working. Accept an answer of $4.04 \text{ (cm}^2\text{)}$ from use of 3sf values in their answer to part (a).

[3 marks]

Total [7 marks]

14. (a) $\mathbf{v}_B = \begin{pmatrix} 2 \\ -3 \end{pmatrix}$ (A1)
 attempt to find any relevant angle (M1)
 $\tan^{-1}\left(\frac{3}{2}\right) (= 56.3099\dots^\circ)$
 $(90^\circ + 56.3099\dots^\circ =) 146^\circ (146.3099\dots^\circ)$ A1
 [3 marks]

- (b) setting $1 + 2t = -2 + 4t$ (M1)
 $t = 1.5$ (hrs.) A1
 [2 marks]

- (c) $\mathbf{r}_B - \mathbf{r}_A = (-3 + 2t)\mathbf{i} + (-7 + 4t)\mathbf{j}$ (M1)
 $-3 + 2t = -(-7 + 4t)$ (M1)
 $t = 1.67$ (hrs.) $\left(1.66666\dots, \frac{5}{3}\right)$ A1
 [3 marks]
 Total [8 marks]

15. (a) (i) 224 g (224.25 g) A1
 (ii) [222.1, 226.4] A1A1

Note: Award **A1** for each correct end of the interval. Accept open or closed (weak or strict) interval notation. Inequalities involving μ would also be accepted, but not involving \bar{x} .
 Award **A1A0** for correct answers not given correct to 4 sf.

[3 marks]

- (b) **EITHER**
 the (population) weight of granules of Apollo coffee is normally distributed. R1
OR
 the readings are independent R1
 [1 mark]
- (c) 226g lies within the confidence interval, R1
 so there is no evidence to dispute the claim on the label. A1

Note: Do not award **R0A1**.

[2 marks]
 Total [6 marks]

16. (a) (1.04, 0.509) ((1.03667..., 0.509085...)) **A1A1**
[2 marks]

(b) attempt to make x the subject for either function **(M1)**
 $x = 4y^2$, $x = \cos^{-1} y$ **A1A1**

attempt to use $V = \pi \int x^2 dy$ **(M1)**

$$V = \pi \int_0^{0.509085\dots} (4y^2)^2 dy + \pi \int_{0.509085\dots}^1 (\cos^{-1} y)^2 dy$$
A1

[5 marks]

(c) = 1.15 (units³) **A2**

Note: Do not **FT** from part (b) to part (c).
Award **A1** for 1.1. with no previous working.

[2 marks]
Total [9 marks]

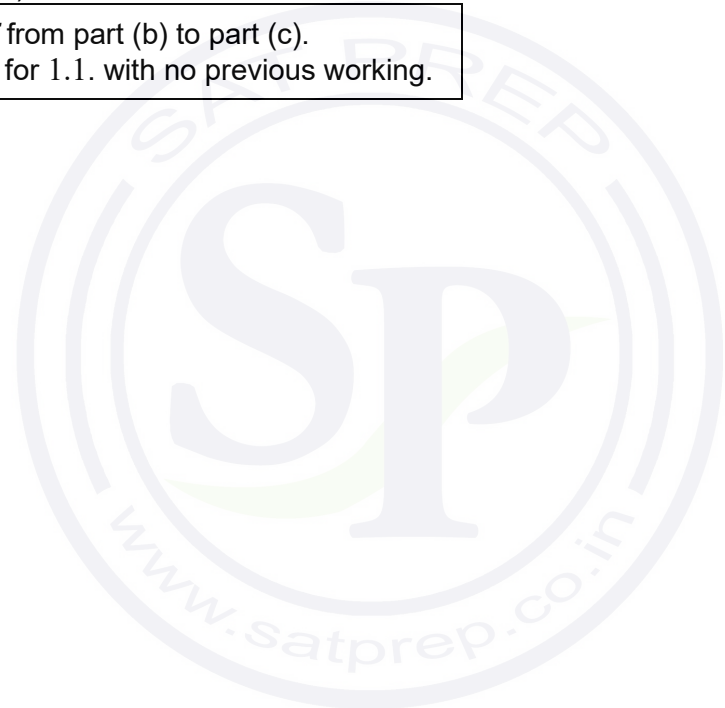

17. (a) $\frac{dy}{dx}$ is undetermined at (0, 1) **R1**

$$\left(\text{so cannot use } y_n = y_{n-1} + h \left(\frac{x}{(x^2 + 1)(2y - 2)} \right) \right)$$

Note: Accept “undefined”, “indeterminate” or “division by zero” in place of “undetermined”.

[1 mark]

(b) $\int (2y - 2) dy = \int \frac{x}{x^2 + 1} dx$ **M1**

$$y^2 - 2y = \frac{1}{2} \ln(x^2 + 1) + c$$
 A1

substituting $x = 0, y = 1$ **M1**

$$c = -1$$

$$y^2 - 2y + 1 = \frac{1}{2} \ln(x^2 + 1)$$

$$(y - 1)^2 = \frac{1}{2} \ln(x^2 + 1)$$
 A1

$$y - 1 = \sqrt{\frac{1}{2} \ln(x^2 + 1)} \text{ (where positive root required as } y \geq 1)$$

$$y = 1 + \sqrt{\frac{\ln(x^2 + 1)}{2}}$$
 AG

[4 marks]

- (c) (when $x = 0.1$) $y = 1.07$ (1.07053...) **A1**

[1 mark]

Total [6 marks]

Markscheme

May 2023

**Mathematics:
applications and interpretation**

Higher level

Paper 1

© International Baccalaureate Organization 2023

All rights reserved. No part of this product may be reproduced in any form or by any electronic or mechanical means, including information storage and retrieval systems, without the prior written permission from the IB. Additionally, the license tied with this product prohibits use of any selected files or extracts from this product. Use by third parties, including but not limited to publishers, private teachers, tutoring or study services, preparatory schools, vendors operating curriculum mapping services or teacher resource digital platforms and app developers, whether fee-covered or not, is prohibited and is a criminal offense.

More information on how to request written permission in the form of a license can be obtained from <https://ibo.org/become-an-ib-school/ib-publishing/licensing/applying-for-a-license/>.

© Organisation du Baccalauréat International 2023

Tous droits réservés. Aucune partie de ce produit ne peut être reproduite sous quelque forme ni par quelque moyen que ce soit, électronique ou mécanique, y compris des systèmes de stockage et de récupération d'informations, sans l'autorisation écrite préalable de l'IB. De plus, la licence associée à ce produit interdit toute utilisation de tout fichier ou extrait sélectionné dans ce produit. L'utilisation par des tiers, y compris, sans toutefois s'y limiter, des éditeurs, des professeurs particuliers, des services de tutorat ou d'aide aux études, des établissements de préparation à l'enseignement supérieur, des fournisseurs de services de planification des programmes d'études, des gestionnaires de plateformes pédagogiques en ligne, et des développeurs d'applications, moyennant paiement ou non, est interdite et constitue une infraction pénale.

Pour plus d'informations sur la procédure à suivre pour obtenir une autorisation écrite sous la forme d'une licence, rendez-vous à l'adresse <https://ibo.org/become-an-ib-school/ib-publishing/licensing/applying-for-a-license/>.

© Organización del Bachillerato Internacional, 2023

Todos los derechos reservados. No se podrá reproducir ninguna parte de este producto de ninguna forma ni por ningún medio electrónico o mecánico, incluidos los sistemas de almacenamiento y recuperación de información, sin la previa autorización por escrito del IB. Además, la licencia vinculada a este producto prohíbe el uso de todo archivo o fragmento seleccionado de este producto. El uso por parte de terceros —lo que incluye, a título enunciativo, editoriales, profesores particulares, servicios de apoyo académico o ayuda para el estudio, colegios preparatorios, desarrolladores de aplicaciones y entidades que presten servicios de planificación curricular u ofrezcan recursos para docentes mediante plataformas digitales—, ya sea incluido en tasas o no, está prohibido y constituye un delito.

En este enlace encontrará más información sobre cómo solicitar una autorización por escrito en forma de licencia: <https://ibo.org/become-an-ib-school/ib-publishing/licensing/applying-for-a-license/>.

Instructions to Examiners

Abbreviations

- M** Marks awarded for attempting to use a correct **Method**.
- A** Marks awarded for an **Answer** or for **Accuracy**; often dependent on preceding **M** marks.
- R** Marks awarded for clear **Reasoning**.
- AG** Answer given in the question and so no marks are awarded.
- FT** Follow through. The practice of awarding marks, despite candidate errors in previous parts, for their correct methods/answers using incorrect results.

Using the markscheme

1 General

Award marks using the annotations as noted in the markscheme eg **M1**, **A2**.

2 Method and Answer/Accuracy marks

- Do **not** automatically award full marks for a correct answer; all working **must** be checked, and marks awarded according to the markscheme.
- It is generally not possible to award **M0** followed by **A1**, as **A** mark(s) depend on the preceding **M** mark(s), if any.
- Where **M** and **A** marks are noted on the same line, e.g. **M1A1**, this usually means **M1** for an **attempt** to use an appropriate method (e.g. substitution into a formula) and **A1** for using the **correct** values.
- Where there are two or more **A** marks on the same line, they may be awarded independently; so if the first value is incorrect, but the next two are correct, award **A0A1A1**.
- Where the markscheme specifies **A3**, **M2** etc., do **not** split the marks, unless there is a note.
- The response to a “show that” question does not need to restate the **AG** line, unless a **Note** makes this explicit in the markscheme.
- Once a correct answer to a question or part question is seen, ignore further working even if this working is incorrect and/or suggests a misunderstanding of the question. This will encourage a uniform approach to marking, with less examiner discretion. Although some candidates may be advantaged for that specific question item, it is likely that these candidates will lose marks elsewhere too.
- An exception to the previous rule is when an incorrect answer from further working is used **in a subsequent part**. For example, when a correct exact value is followed by an incorrect decimal approximation in the first part and this approximation is then used in the second part. In this situation, award **FT** marks as appropriate but do not award the final **A1** in the first part. Examples:

	Correct answer seen	Further working seen	Any FT issues?	Action
1.	$8\sqrt{2}$	5.65685... (incorrect decimal value)	No. Last part in question.	Award A1 for the final mark (condone the incorrect further working)
2.	$\frac{35}{72}$	0.468111... (incorrect decimal value)	Yes. Value is used in subsequent parts.	Award A0 for the final mark (and full FT is available in subsequent parts)

3 Implied marks

Implied marks appear in **brackets e.g. (M1)**, and can only be awarded if **correct** work is seen or implied by subsequent working/answer.

4 Follow through marks (only applied after an error is made)

Follow through (**FT**) marks are awarded where an incorrect answer from one **part** of a question is used correctly in **subsequent** part(s) (e.g. incorrect value from part (a) used in part (d) or incorrect value from part (c)(i) used in part (c)(ii)). Usually, to award **FT** marks, **there must be working present** and not just a final answer based on an incorrect answer to a previous part. However, if all the marks awarded in a subsequent part are for the answer or are implied, then **FT** marks should be awarded for *their* correct answer, even when working is not present.

For example: following an incorrect answer to part (a) that is used in subsequent parts, where the markscheme for the subsequent part is **(M1)A1**, it is possible to award full marks for *their* correct answer, **without working being seen**. For longer questions where all but the answer marks are implied this rule applies but may be overwritten by a **Note** in the Markscheme.

- Within a question part, once an **error** is made, no further **A** marks can be awarded for work which uses the error, but **M** marks may be awarded if appropriate.
- If the question becomes much simpler because of an error then use discretion to award fewer **FT** marks, by reflecting on what each mark is for and how that maps to the simplified version.
- If the error leads to an inappropriate value (e.g. probability greater than 1, $\sin \theta = 1.5$, non-integer value where integer required), do not award the mark(s) for the final answer(s).
- The markscheme may use the word “their” in a description, to indicate that candidates may be using an incorrect value.
- If the candidate’s answer to the initial question clearly contradicts information given in the question, it is not appropriate to award any **FT** marks in the subsequent parts. This includes when candidates fail to complete a “show that” question correctly, and then in subsequent parts use their incorrect answer rather than the given value.
- Exceptions to these **FT** rules will be explicitly noted on the markscheme.
- If a candidate makes an error in one part but gets the correct answer(s) to subsequent part(s), award marks as appropriate, unless the command term was “Hence”.

5 Mis-read

If a candidate incorrectly copies values or information from the question, this is a mis-read (**MR**). A candidate should be penalized only once for a particular misread. Use the **MR** stamp to indicate that this has been a misread and do not award the first mark, even if this is an **M** mark, but award all others as appropriate.

- If the question becomes much simpler because of the **MR**, then use discretion to award fewer marks.
- If the **MR** leads to an inappropriate value (e.g. probability greater than 1, $\sin \theta = 1.5$, non-integer value where integer required), do not award the mark(s) for the final answer(s).
- Miscopying of candidates' own work does **not** constitute a misread, it is an error.
- If a candidate uses a correct answer, to a "show that" question, to a higher degree of accuracy than given in the question, this is NOT a misread and full marks may be scored in the subsequent part.
- **MR** can only be applied when work is seen. For calculator questions with no working and incorrect answers, examiners should **not** infer that values were read incorrectly.

6 Alternative methods

Candidates will sometimes use methods other than those in the markscheme. Unless the question specifies a method, other correct methods should be marked in line with the markscheme. If the command term is 'Hence' and not 'Hence or otherwise' then alternative methods are not permitted unless covered by a note in the mark scheme.

- Alternative methods for complete questions are indicated by **METHOD 1**, **METHOD 2**, etc.
- Alternative solutions for parts of questions are indicated by **EITHER . . . OR**.

7 Alternative forms

Unless the question specifies otherwise, **accept** equivalent forms.

- As this is an international examination, accept all alternative forms of **notation** for example 1.9 and 1,9 or 1000 and 1,000 and 1.000.
- Do not accept final answers written using calculator notation. However, **M** marks and intermediate **A** marks can be scored, when presented using calculator notation, provided the evidence clearly reflects the demand of the mark.
- In the markscheme, equivalent **numerical** and **algebraic** forms will generally be written in brackets immediately following the answer.
- In the markscheme, some **equivalent** answers will generally appear in brackets. Not all equivalent notations/answers/methods will be presented in the markscheme and examiners are asked to apply appropriate discretion to judge if the candidate work is equivalent.

8 Format and accuracy of answers

If the level of accuracy is specified in the question, a mark will be linked to giving the answer to the required accuracy. If the level of accuracy is not stated in the question, the general rule applies to final answers: *unless otherwise stated in the question all numerical answers must be given exactly or correct to three significant figures.*

Where values are used in subsequent parts, the markscheme will generally use the exact value, however candidates may also use the correct answer to a “correct” level of accuracy (e.g 3 sf) in subsequent parts. The markscheme will often explicitly include the subsequent values that come “from the use of 3 sf values”.

Simplification of final answers: Candidates are advised to give final answers using good mathematical form. In general, for an **A** mark to be awarded, arithmetic should be completed, and any values that lead to integers should be simplified; for example, $\sqrt{\frac{25}{4}}$ should be written as $\frac{5}{2}$.

An exception to this is simplifying fractions, where lowest form is not required (although the numerator and the denominator must be integers); for example, $\frac{10}{4}$ may be left in this form or written as $\frac{5}{2}$. However, $\frac{10}{5}$ should be written as 2, as it simplifies to an integer.

Algebraic expressions should be simplified by completing any operations such as addition and multiplication, e.g. $4e^{2x} \times e^{3x}$ should be simplified to $4e^{5x}$, and $4e^{2x} \times e^{3x} - e^{4x} \times e^x$ should be simplified to $3e^{5x}$. Unless specified in the question, expressions do not need to be factorized, nor do factorized expressions need to be expanded, so $x(x+1)$ and $x^2 + x$ are both acceptable.

Please note: intermediate **A** marks do NOT need to be simplified.

9 Calculators

A GDC is required for this paper, but If you see work that suggests a candidate has used any calculator not approved for IB DP examinations (eg CAS enabled devices), please follow the procedures for malpractice.

10. Presentation of candidate work

Crossed out work: If a candidate has drawn a line through work on their examination script, or in some other way crossed out their work, do not award any marks for that work unless an explicit note from the candidate indicates that they would like the work to be marked.

More than one solution: Where a candidate offers two or more different answers to the same question, an examiner should only mark the first response unless the candidate indicates otherwise. If the layout of the responses makes it difficult to judge, examiners should apply appropriate discretion to judge which is “first”.



1. (a) $N = 24$
 $I = 4$
 $PV = \pm 1000$
 $PMT = \pm 100$
 $P/Y = 12$
 $C/Y = 12$

(M1)(A1)

Note: Award **M1** for an attempt to use a financial app in their technology (i.e. at least three entries seen, but not necessarily correct).
 Approaches that use the compound interest formula receive no marks.
 Award **A1** for correct values of PV and PMT (signs must be the same) **and** a correct value of N .

$FV = (\$)3577.43$

A1

Note: Award at most **(M1)(A1)A0** if the final answer is negative or not rounded to 2 dp.

[3 marks]

(b) $N = 36.5$ (36.4689...)

(A1)

$N = 37$ (months)

A1

Note: Allow **FT** from incorrect GDC inputs seen in part (a) for the first **A1** providing that PV and FV have opposite signs and the resulting value of N is positive.

[2 marks]

[Total: 5 marks]

2. (a) $H_0 : \mu_b = \mu_m$ **A1**
 $H_1 : \mu_b > \mu_m$ **A1**

Note: Accept equivalent statements in words such as “the **mean** score of bilingual people equals the **mean** score of monolingual people”.

[2 marks]

- (b) 0.119 (0.119395...) **A2**
[2 marks]

- (c) $0.119395... > 0.05$ ($11.9395...% > 5%$) **R1**
 (fail to reject H_0) there is insufficient evidence to suggest that bilingual people have better memory retention than monolingual people **A1**

Note: Do not award **R0A1**.
 The answer to part (c) MUST be consistent with **their** hypotheses and **their** p -value.

[2 marks]

[Total: 6 marks]

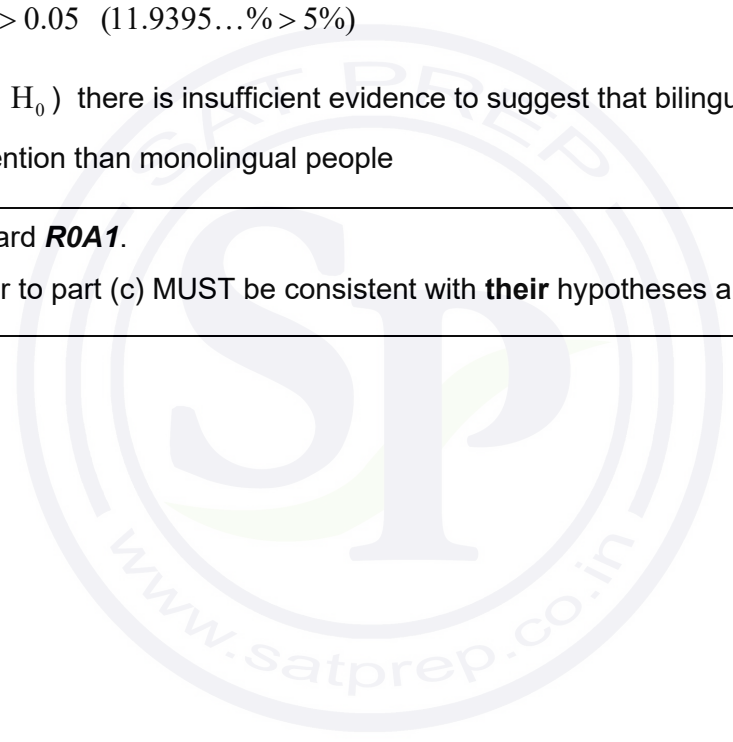

3. (a) attempt to use distance formula for points D and A (M1)

$$DA = \sqrt{11^2 + 7^2}$$

$$= 13.0 \text{ (miles) } (13.0384\dots, \sqrt{170})$$

A1

Note: Accept 13 miles. Award **MOAO** for finding the equation of the line DA.
DA may be seen in part (b) but this should not be accepted as answer for part (a).

[2 marks]

(b) $(DB = \sqrt{13^2 + 5^2} =) 13.9 (13.9283\dots, \sqrt{194})$ **AND**

$$(DC = \sqrt{4^2 + 12^2} =) 12.6 (12.6491\dots, \sqrt{160})$$

A1

recognizing closest town is best estimate

(M1)

(town C is closest)

30 °C

A1

Note: If their DA from part (a) is the shortest length, then allow **FT** in (b).

[3 marks]

[Total: 5 marks]

4. (a) attempt to substitute $h = 10$ and at least two different values of y into the trapezoidal rule **(M1)**

$$\frac{10}{2}((0+0) + 2(3+8+9))$$

$$= 200 \text{ (cm}^2\text{)}$$

A1

[2 marks]

- (b) (i) $\int_0^{40} 0.04x^2 - 0.001x^3 dx$ **OR** $\int_0^{40} y dx$ **A1A1**

Note: Award **A1** for a correct integral (including dx), **A1** for correct limits in the correct location.

- (ii) 213.33 (cm²) **A2**

Note: Answer must be given to 2 decimal places to award **A2**. Award **A1A0** for a correct answer given to an incorrect accuracy of at least 3 significant figures, e.g. 213 (cm²).

[4 marks]

- (c) attempt to substitute their parts (a) and (b)(ii) into percentage error formula **(M1)**

$$\left| \frac{213.333... - 200}{213.333...} \right| \times 100$$

$$= 6.25\% \text{ (6.24999...(\%))}$$
A1

Note: Award **(M1)A0** for a final answer of -6.25% or 0.0625 .

[2 marks]

[Total: 8 marks]

5. METHOD 1

diagram showing (approximately) correct directions (and order) for the 315° and 045° **(A1)**

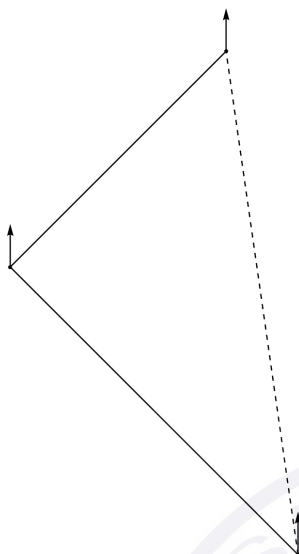

recognizing right angle triangle **(M1)**

correct expression to find second angle in triangle **(A1)**

e.g. $\arctan\left(\frac{6}{8}\right)$ **OR** $\arctan\left(\frac{8}{6}\right)$

correct expression to find bearing **(A1)**

e.g. $\arctan\left(\frac{6}{8}\right) + 135^\circ$ **OR** $360^\circ - \left(\arctan\left(\frac{8}{6}\right) + 135^\circ\right)$

$= 172^\circ$ (171.869...°) **A1**

continued...

Question 5 continued

METHOD 2

diagram showing (approximately) correct directions (and order) for the 315° and 045°
(these may be shown in reverse as the return journey) (A1)

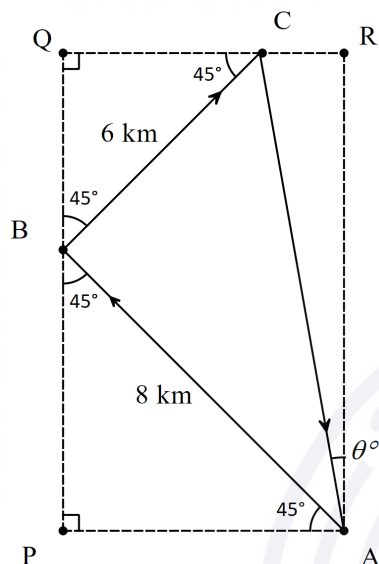

finding the lengths marked AP, BP, CQ and BQ in the diagram (M1)

$$AP = BP = 8 \frac{\sqrt{2}}{2} = 5.6568\dots$$

$$CQ = BQ = 6 \frac{\sqrt{2}}{2} = 4.2426\dots$$

Note: This may be done using a vector approach.

using $\tan \theta^\circ = \frac{AP - CQ}{PB + BQ}$ or equivalent to find the direction of AC (A1)

correct expression to find bearing (A1)

$$180^\circ - \arctan \left(\frac{8 \frac{\sqrt{2}}{2} + 6 \frac{\sqrt{2}}{2}}{8 \frac{\sqrt{2}}{2} - 6 \frac{\sqrt{2}}{2}} \right)$$

$$= 172^\circ \quad (171.869\dots^\circ)$$

A1

[Total: 5 marks]

6. (a) (i) **METHOD 1**

attempt to find change in height of the ball using gradient **(M1)**

$$\frac{a}{0.43} = (-)0.045$$

$$a = (-)0.045 \times 0.43$$

$$a = (-)0.0194(\text{m}) \quad (0.01935 \text{ (m)}) \quad \textbf{A1}$$

METHOD 2

attempt to find height at back of home plate **(M1)**

horizontal distance to the front of the home plate = 16.6666... (m)

height at the back of the home plate = $-0.045(16.6666... + 0.43) + 2$

(= 1.23065 (m))

Note: The **M1** can be awarded for 16.6666... + 0.43 seen at some point.

$$(a = 1.25 - 1.23065...)$$

$$(a =) (-)0.0194 \text{ (m)} \quad (0.01935 \text{ (m)}) \quad \textbf{A1}$$

(ii) $1.25 - 0.01935 = 1.23065$ (may be seen in part (a)(i)) **A1**

$$0.53 < 1.23065 < 1.24 \quad \textbf{R1}$$

therefore a strike **AG**

Note: Do not award **A0R1**.

[4 marks]

continued...

Question 6 continued

(b) **METHOD 1**

indication of $d = 96$ in the function $h(d)$ or its graph

(M1)

EITHER

$$(h(96)=) -0.01(96)^2 + 1.04(96) + 0.66$$

OR

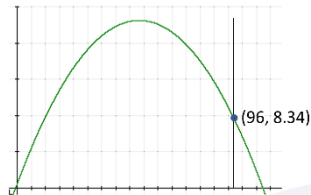

THEN

$$(h(96)=) 8.34 \text{ (m)}$$

A1

$8.34 > 5$ so the ball will go over the wall.

A1

METHOD 2

indication of $h = 5$ in the function $h(d)$ or its graph

(M1)

EITHER

$$5 = -0.01d^2 + 1.04d + 0.66$$

OR

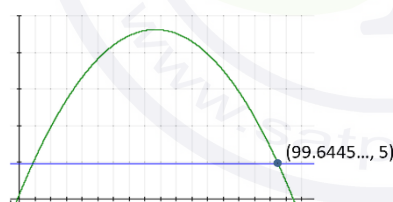

THEN

$$d = 99.6 \text{ (m)} \quad (99.6445... \text{ (m)}) \quad (d = 4.35548... \text{ (m)} \text{ may also be seen})$$

A1

$96 < 99.6445...$ so the ball will go over the wall.

A1

[3 marks]

[Total: 7 marks]

7. (a) attempt to find the vector product (e.g. one term correct) (M1)

$$\begin{pmatrix} 0 \\ 6 \\ 1 \end{pmatrix} \times \begin{pmatrix} 7 \\ 3 \\ 0 \end{pmatrix} = \begin{pmatrix} -3 \\ 7 \\ -42 \end{pmatrix}$$

A1

[2 marks]

- (b) **METHOD 1**

attempt to use the vector product formula for the area of triangle

(condone incorrect signs and missing $\frac{1}{2}$) (M1)

$$\text{area} = \frac{1}{2} \sqrt{3^2 + 7^2 + 42^2}$$

$$= 21.3 \text{ (m}^2\text{)} \text{ (21.3424\dots, } \frac{1}{2} \sqrt{1822}\text{)} \quad \text{A1}$$

METHOD 2

find θ using $\vec{AB} \times \vec{AC} = |\vec{AB}| |\vec{AC}| \sin \theta$ (M1)

$$\theta = 67.1^\circ \text{ (67.1350^\circ \dots, 1.171728 \dots radians)}$$

$$\text{then area} = \frac{1}{2} |\vec{AB}| |\vec{AC}| \sin \theta$$

$$= 21.3 \text{ (m}^2\text{)} \left(21.3424\dots, \frac{1}{2} \sqrt{1822} \right) \quad \text{A1}$$

[2 marks]

continued...

Question 7 continued

(c) $AC = 7.61577... (\sqrt{58})$ **(A1)**

setting the area formula $\frac{1}{2} \times \text{base} \times \text{height}$ equal to their part (b) **(M1)**

$$BX = \frac{2 \times 21.3424...}{\sqrt{58}}$$

$= 5.60$ (5.60480...) **A1**

Note: Award **A1** for 5.6.

Award **A1** for 5.59 (5.5936...) from the use of 21.3 to 3 sf.

[3 marks]

(d) attempting to set up a trig ratio **(M1)**

angle is $\arcsin\left(\frac{1}{BX}\right)$

10.3° (10.2776...°, 0.179378... radians) **A1**

[2 marks]

[Total: 9 marks]

8. (a) H_0 : X and Y are not (linearly) correlated **OR** $\rho = 0$ **A1**
 H_1 : X and Y are (linearly) correlated **OR** $\rho \neq 0$ **A1**

Note: Accept “independent” or “not associated” in place of “not correlated”.
 If H_0 and H_1 are reversed, then award **A0A1**.

[2 marks]

- (b) (i) $r = 0.849$ (0.848886...) **A1**
 (ii) p -value = 0.0325 (0.0325277...) **A2**

Note: Award **A1** for p -value = 0.033 or p -value = 0.03 .
 Award **FT** for $\rho > 0$ or $\rho < 0$ in part (a), p -value = 0.0163 (0.0162638...)
 or p -value = 0.984 (0.983736...)
 Award the full marks for seeing the values of r and p -value from the
 markscheme when H_0 and H_1 are reversed in part (a).

[3 marks]

- (c) $0.0325 < 0.05$ **R1**
 (so we reject H_0 in favour of H_1)
 (there is sufficient evidence to suggest) X and Y are (linearly) correlated **A1**

Note: Their conclusion must be consistent with their p -value and their hypotheses and
 it must be in context.

[2 marks]

[Total: 7 marks]

9. (a) attempt to find the difference between 75.7 and 67.3 (M1)

$$\frac{75.7 - 67.3}{2}$$

4.2 (km h⁻¹)

A1

[2 marks]

- (b) **METHOD 1 (Comparing areas above and below the mean)**

P(67.3 < speed < 74) **OR** Normal CDF(67.3, 74, 67.3, 4.2) **OR** sketch of normal distribution with 67.3 and 74 labelled and shaded between (M1)

area of region between mean and q is at least 0.445 (0.444670...) A1

Hence no more than 0.375 (0.375329...) between mean and p R1

The region between p and q is not symmetrical AG

METHOD 2 (Comparing areas in the tails)

attempt to calculate probability that speed < p and speed > q with $q=74$ (M1)

$$P(\text{speed} < 74) = 0.944670\dots$$

$$P(\text{speed} < p) = (0.944670\dots - 0.82) = 0.124670\dots$$

$$P(\text{speed} > q) = (1 - 0.944670\dots) = 0.0553295\dots$$

A1

if $q \geq 74$, then $P(\text{speed} > q) \leq 0.0553295$ and $P(\text{speed} < p) \geq 0.124670$ so

$P(\text{speed} > q)$ will never equal $P(\text{speed} < p)$ R1

the region between p and q is not symmetrical AG

continued...

Question 9 continued

METHOD 3 (Assumption of symmetry comparing speeds)

attempt to calculate area below q assuming distribution is symmetrical **(M1)**

e.g. $P(\text{speed} < q) = 0.82 + \frac{1}{2} \times 0.18$ (0.91)

EITHER

$(q =) 72.9$ (72.9311...) **A1**

$72.9 < 74$ so 74 would not be in the region **R1**

the region between p and q is not symmetrical **AG**

OR

$P(\text{speed} < 74) = 0.945$ (0.944670...) **A1**

$0.945 > 0.91$ so 74 would not be in the region **R1**

the region between p and q is not symmetrical **AG**

METHOD 4 (Assumption of symmetry comparing areas)

attempt to calculate symmetrical area with 74 as a boundary **(M1)**

$P(60.6 < \text{speed} < 74)$ **OR** Normal CDF(60.6, 74, 67.3, 4.2) **OR**

$P(67.3 < \text{speed} < 74)$ **OR** Normal CDF(67.3, 74, 67.3, 4.2)

EITHER

0.889 (0.889340...) **A1**

$0.889 > 0.82$ so 74 would not be in the region **R1**

the region between p and q is not symmetrical **AG**

OR

0.445 (0.444670...) **A1**

$0.445 > 0.82 \div 2$ so 74 would not be in the region **R1**

the region between p and q is not symmetrical **AG**

[3 marks]

[Total: 5 marks]

10. (a) $y = x$

A1

[1 mark]

(b) **METHOD 1**

equation has the form $y = ax^2 + bx + c$

when $x = 0, y = 0$ so $c = 0$

$$\frac{dy}{dx} = 2ax + b$$

attempt to find the value of b by setting *their* derivative equal to 1 when x is 0 **(M1)**

$$2a(0) + b = 1$$

$$b = 1 \quad \text{A1}$$

when $x = -2, y = 0$

$$a = \frac{1}{2} \quad \text{(and hence } y = \frac{1}{2}x^2 + x) \quad \text{A1}$$

METHOD 2

equation has the form $y = ax(x + 2)$ **OR** $y = ax^2 + 2ax$ **A1**

$$\frac{dy}{dx} = 2ax + 2a$$

attempt to find the value of a by setting *their* derivative equal to 1 when x is 0 **(M1)**

$$a = \frac{1}{2} \quad \text{(and hence } y = \frac{1}{2}x^2 + x) \quad \text{A1}$$

Note: Writing $y = x(x + 2)$ is incorrect and gains no marks.

[3 marks]

continued...

Question 10 continued

(c) equation is $y = ax^2 + bx + c$

finding an expression for $\frac{dy}{dx}$ with unknown coefficients (M1)

$$\frac{dy}{dx} = 2ax + b$$

setting up two equations using two points AND/OR one equation using the gradient function (M1)

three correct equations (A1)

$$9a + 3b + c = 3$$

$$36a + 6b + c = 2$$

$$6a + b = 1$$

$$a = -\frac{4}{9}, b = \frac{11}{3}, c = -4 \quad (a = -0.444444\dots, b = 3.66666\dots, c = -4) \quad \text{A1}$$

(and hence $y = -\frac{4}{9}x^2 + \frac{11}{3}x - 4$)

[4 marks]

$$(d) \quad f(x) = \begin{cases} \frac{1}{2}x^2 + x & , \quad -2 \leq x < 0 \\ x & , \quad 0 \leq x \leq 3 \\ -\frac{4}{9}x^2 + \frac{11}{3}x - 4 & , \quad 3 < x \leq 6 \end{cases} \quad \text{A1}$$

Note: Condone open or closed endpoints for all intervals.

Condone y in place of $f(x)$.

Allow **FT** from parts (a), (b) and (c).

[1 mark]

[Total: 9 marks]

11. Let $D = O - L - L$ (A1)
- (mean =) $205 - 105 - 105$ (= -5) (A1)
- manipulating variances (not standard deviations) (M1)
- (variance =) $25 + 9 + 9$ (= 43) **OR** (SD =) 6.55743... (A1)
- $D \sim N(205 - 105 - 105, 25 + 9 + 9)$
- attempt to find the probability that $D > 0$ (M1)
- $P(D > 0)$
- = 0.223 (0.222882...) A1

Note: If $D = O - 2L$ is seen or implied, award at most (A0)A1(M0)(A0)M1A0.

[Total: 6 marks]

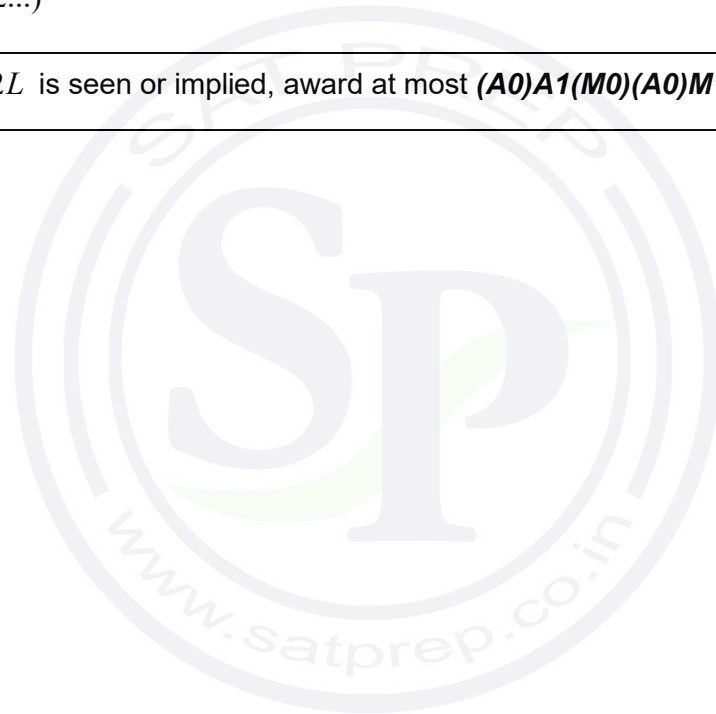

12. METHOD 1 Analytical approach

attempt to express V_1 or V_2 in exponential form **(M1)**

e.g. $V_1 = \text{Im}(6e^{i(at+\frac{\pi}{6})})$, $V_2 = \text{Im}(6e^{i(at+\frac{\pi}{2})})$

Note: Accept angles in radians or degrees.

$(V_1 + V_2 =) 6e^{ix\frac{\pi}{6}} + 6e^{ix\frac{\pi}{2}}$ **(A1)**

Note: This mark can be awarded even if seen as part of a correct larger expression.

$= 10.4e^{1.05i} \left(6\sqrt{3}e^{\frac{i\pi}{3}} \right)$ **(A1)**

so V is 10.4 (10.3923..., $6\sqrt{3}$) and θ is 60 (degrees) **A1A1**

Note: Accept any value for θ that rounds to a 2sf answer of 60.
 Do **not** accept a final answer for an angle in radians.
 Do **not** award **A1** for answer of 60° resulting from incorrect working.

continued...

Question 12 continued

METHOD 2 Graphical approach

let $at = x$ and plot $V_1 + V_2$ curves on GDC

(M1)

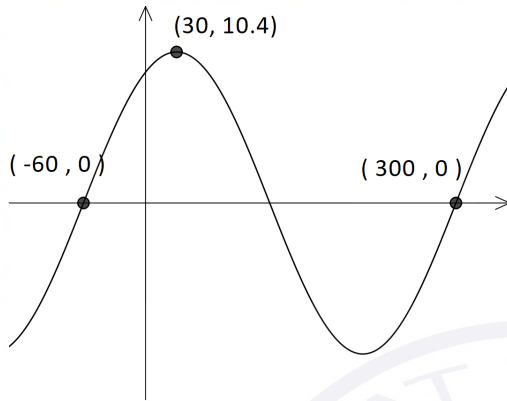

attempt to find maximum

(M1)

$$V = 10.4$$

A1

attempt to find any x -axis intercept (either -60 or 300)

(M1)

$$\theta = 60 \text{ (degrees)} \quad (\theta = -300 \text{ (degrees)})$$

A1

continued...

Question 12 continued

METHOD 3 Geometric approach

considering the rhombus

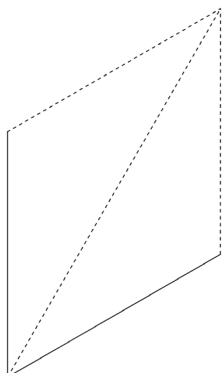

(M1)

$$V = \sqrt{6^2 + 6^2 - 2 \times 6 \times 6 \cos 120^\circ}$$

(M1)

$$(\text{= } \sqrt{108} = 6\sqrt{3}) = 10.4 \text{ (10.3923...)}$$

A1

$$\theta = 60 \text{ (degrees)}$$

A2

Note: An answer of $\theta = -300$. is most likely to be seen in METHOD 2, but should be condoned in METHODS 1 and 3 if seen there.

[Total: 5 marks]

13. $\frac{dx}{dt} = y$ (A1)

$\frac{dy}{dt} = -10x - 2y$ (A1)

Note: Writing $\frac{d^2x}{dt^2} = -10x - 2\frac{dx}{dt}$ is a valid approach and should be awarded **A1A1**.

attempt to use the Euler equations shown by finding either a correct x_{n+1} or y_{n+1} (M1)

correct equations for both x_{n+1} and y_{n+1} (A1)

$x_{n+1} = x_n + 0.1(y_n), \quad y_{n+1} = y_n + 0.1(-10x_n - 2y_n)$ (accept equivalent notation)

$(t_{n+1} = t_n + 0.1)$

Note: All of the above marks can be implied by a correct second row in a table **OR** by a correct f_1 and f_2 clearly identified for use in Euler's method formula.

T	x	y
0	0.75	0
0.1	0.75	-0.75
0.2	0.675	-1.35
0.3	0.54	-1.755
0.4	0.3645	-1.944
0.5	0.1701	

so estimate is 0.170 A2

Note: Accept 0.17 rounded to 2 sf.

[Total: 6 marks]

14. METHOD 1 Analytical approach

recognizing that the linear equation must be expressed in log form (M1)

$$\log y = m \log x + \log c \quad (\text{or } \log y = m \log x + C)$$

EITHER

use of slope formula (must involve logs) (M1)

$$m = \frac{\log(34.822) - \log(13.1951)}{\log(4) - \log(2)} = 1.4 \quad \text{A1}$$

attempt to substitute a value (M1)

$$\log c = \log(13.1951) - 1.4 \log 2 (= 0.69897\dots)$$

$$\Rightarrow c = 5 \quad \text{A1}$$

OR

$$y = c \cdot x^m \quad \text{(A1)}$$

attempt to set up two equations involving power functions (M1)

$$13.1951 = c \times 2^m \quad \text{and} \quad 34.822 = c \times 4^m$$

$$2^m = \frac{34.822}{13.1951} = 2.639\dots \Rightarrow m = \log_2 2.639\dots = 1.4 \quad \text{A1}$$

$$c = \frac{13.1951}{2.639\dots} = 5 \quad \text{A1}$$

THEN

(so the equation is) $y = 5 \times x^{1.4}$ A1

METHOD 2 Regression analysis

recognizing that a log-log graph results in a power function model (M1)

$$y = a \times x^b$$

attempt to find a power regression model using the given two points (M1)

$$a = 5 \quad \text{and} \quad b = 1.4 \quad \text{(A1)(A1)}$$

(so the equation is) $y = 5 \times x^{1.4}$ A2

[Total: 6 marks]

15. METHOD 1 Using the volume formula

volume of a “full” or “half” cylinder (seen anywhere) (A1)

$$\pi \int_2^4 4^2 dy, \quad \pi \times 4^2 \times 2, \quad 32\pi \quad (100.53\dots) \quad \text{OR}$$

$$\pi \int_2^3 4^2 dy, \quad \pi \times 4^2 \times 1, \quad 16\pi \quad (50.265\dots)$$

one correct equation for the diagonal lines (seen anywhere) (A1)

$$y = \frac{1}{2}x \quad \text{or} \quad y = 6 - \frac{1}{2}x$$

attempt to write one equation x in terms of y (M1)

$$x = 2y, \quad x = 12 - 2y$$

EITHER (symmetry plus the volume of the “half” cylinder)

recognition of symmetry between $y = 1$ and $y = 3$ (M1)

$$2\pi \left(\int_1^2 (2y)^2 dy + \int_2^3 4^2 dy \right) \quad \text{(A1)}$$

OR (symmetry plus volume of the “full” cylinder)

recognition of symmetry between $y = 1$ and $y = 2$ (M1)

$$2\pi \left(\int_1^2 (2y)^2 dy \right) + \int_2^4 4^2 dy \quad \text{(A1)}$$

OR (calculation of separate parts)

$$\pi \left(\int_1^2 (2y)^2 dy + \int_2^4 4^2 dy + \int_4^5 (-2y + 12)^2 dy \right) \quad \text{(A1)}$$

THEN

(volume of the solid=) $159 \left(159.174\dots, \frac{152\pi}{3} \right)$ A1

continued...

Question 15 continued

METHOD 2 Geometric approach using cones and cylinders

volume of a cylinder (seen anywhere) **(A1)**

$$\pi \times 4^2 \times 2, 32\pi \text{ (100.53...)} \text{ (a full cylinder) OR}$$

$$\pi \times 4^2 \times 1, 16\pi \text{ (50.265...)} \text{ (a half cylinder)}$$

using volume of cone formula to find the volume of the truncated cone **(M1)**

correct expression to find the volume of the truncated cone (seen anywhere) **(A1)**

$$\frac{1}{3}(\pi \times 4^2 \times 2 - \pi \times 2^2 \times 1)$$

attempt to find an expression for total volume using symmetry or individual parts **(M1)**

correct expression for total volume **(A1)**

$$2\left(\frac{1}{3}(\pi 4^2 \times 2 - \pi 2^2 \times 1) + \pi 4^2 \times 1\right) \text{ OR } \frac{1}{3}(\pi 4^2 \times 2 - \pi 2^2 \times 1) + \pi 4^2 \times 2 + \frac{1}{3}(\pi 4^2 \times 2 - \pi 2^2 \times 1)$$

(volume of the solid=) $159 \left(159.174..., \frac{152\pi}{3}\right)$ **A1**

Note: There are other valid approaches possible.

[Total: 6 marks]

16. (a) attempt to find what the model predicts in terms of k **(M1)**

$$k, \frac{k}{4}, \frac{k}{25}$$

correct expression for sum of square residuals **(A1)**

$$(k - 42)^2 + \left(\frac{k}{4} - 11\right)^2 + \left(\frac{k}{25} - 1.5\right)^2$$

valid attempt to find c by expanding or recognizing the constant terms **(M1)**

$$c = 42^2 + 11^2 + 1.5^2$$

$$= 1887.25$$

A1

[4 marks]

- (b) valid method to find the k value at the minimum **(M1)**

$$k = \frac{89.62}{2 \times 1.0641} (= 42.1107\dots), \text{ graph, completing the square}$$

(so least squares regression is) $I = \frac{42.1}{d^2}$

A1

[2 marks]

[Total: 6 marks]

17. (a) attempt to use the chain rule to set up a related rate (M1)

correct expression A1

$$\frac{dx}{d\theta} = \frac{dx}{dt} \div \frac{d\theta}{dt} \quad \text{OR} \quad \frac{-250}{0.075}$$

$$= -\frac{10000}{3} \quad \text{AG}$$

[2 marks]

(b) $x(\theta) = \frac{3000}{\tan \theta}$ A1

[1 mark]

(c) attempt to use chain rule OR quotient rule (M1)

$$\frac{-3000}{\tan^2 \theta \times \cos^2 \theta}, \frac{-3000(\sin \theta(-\sin \theta) - \cos^2 \theta)}{\sin^2 \theta} \quad \text{(A1)}$$

$$= -\frac{3000}{\sin^2 \theta} \quad \text{A1}$$

[3 marks]

(d) setting their equation in part (c) equal to the given expression in part (a) (M1)

$$-\frac{3000}{\sin^2 \theta} = -\frac{10000}{3}$$

$$\theta = 1.24904... \quad \text{(A1)}$$

$$x(1.24904...) = 1000 \text{ m} \quad \text{A1}$$

[3 marks]

[Total: 9 marks]

Markscheme

November 2022

**Mathematics:
applications and interpretation**

Higher level

Paper 1

© International Baccalaureate Organization 2022

All rights reserved. No part of this product may be reproduced in any form or by any electronic or mechanical means, including information storage and retrieval systems, without the prior written permission from the IB. Additionally, the license tied with this product prohibits use of any selected files or extracts from this product. Use by third parties, including but not limited to publishers, private teachers, tutoring or study services, preparatory schools, vendors operating curriculum mapping services or teacher resource digital platforms and app developers, whether fee-covered or not, is prohibited and is a criminal offense.

More information on how to request written permission in the form of a license can be obtained from <https://ibo.org/become-an-ib-school/ib-publishing/licensing/applying-for-a-license/>.

© Organisation du Baccalauréat International 2022

Tous droits réservés. Aucune partie de ce produit ne peut être reproduite sous quelque forme ni par quelque moyen que ce soit, électronique ou mécanique, y compris des systèmes de stockage et de récupération d'informations, sans l'autorisation écrite préalable de l'IB. De plus, la licence associée à ce produit interdit toute utilisation de tout fichier ou extrait sélectionné dans ce produit. L'utilisation par des tiers, y compris, sans toutefois s'y limiter, des éditeurs, des professeurs particuliers, des services de tutorat ou d'aide aux études, des établissements de préparation à l'enseignement supérieur, des fournisseurs de services de planification des programmes d'études, des gestionnaires de plateformes pédagogiques en ligne, et des développeurs d'applications, moyennant paiement ou non, est interdite et constitue une infraction pénale.

Pour plus d'informations sur la procédure à suivre pour obtenir une autorisation écrite sous la forme d'une licence, rendez-vous à l'adresse <https://ibo.org/become-an-ib-school/ib-publishing/licensing/applying-for-a-license/>.

© Organización del Bachillerato Internacional, 2022

Todos los derechos reservados. No se podrá reproducir ninguna parte de este producto de ninguna forma ni por ningún medio electrónico o mecánico, incluidos los sistemas de almacenamiento y recuperación de información, sin la previa autorización por escrito del IB. Además, la licencia vinculada a este producto prohíbe el uso de todo archivo o fragmento seleccionado de este producto. El uso por parte de terceros —lo que incluye, a título enunciativo, editoriales, profesores particulares, servicios de apoyo académico o ayuda para el estudio, colegios preparatorios, desarrolladores de aplicaciones y entidades que presten servicios de planificación curricular u ofrezcan recursos para docentes mediante plataformas digitales—, ya sea incluido en tasas o no, está prohibido y constituye un delito.

En este enlace encontrará más información sobre cómo solicitar una autorización por escrito en forma de licencia: <https://ibo.org/become-an-ib-school/ib-publishing/licensing/applying-for-a-license/>.

Instructions to Examiners

Abbreviations

- M** Marks awarded for attempting to use a correct **Method**.
A Marks awarded for an **Answer** or for **Accuracy**; often dependent on preceding **M** marks.
R Marks awarded for clear **Reasoning**.
AG Answer given in the question and so no marks are awarded.
FT Follow through. The practice of awarding marks, despite candidate errors in previous parts, for their correct methods/answers using incorrect results.

Using the markscheme

1 General

Award marks using the annotations as noted in the markscheme eg **M1**, **A2**.

2 Method and Answer/Accuracy marks

- Do **not** automatically award full marks for a correct answer; all working **must** be checked, and marks awarded according to the markscheme.
- It is generally not possible to award **M0** followed by **A1**, as **A** mark(s) depend on the preceding **M** mark(s), if any.
- Where **M** and **A** marks are noted on the same line, e.g. **M1A1**, this usually means **M1** for an **attempt** to use an appropriate method (e.g. substitution into a formula) and **A1** for using the **correct** values.
- Where there are two or more **A** marks on the same line, they may be awarded independently; so if the first value is incorrect, but the next two are correct, award **A0A1A1**.
- Where the markscheme specifies **A3**, **M2** etc., do **not** split the marks, unless there is a note.
- The response to a “show that” question does not need to restate the **AG** line, unless a **Note** makes this explicit in the markscheme.
- Once a correct answer to a question or part question is seen, ignore further working even if this working is incorrect and/or suggests a misunderstanding of the question. This will encourage a uniform approach to marking, with less examiner discretion. Although some candidates may be advantaged for that specific question item, it is likely that these candidates will lose marks elsewhere too.
- An exception to the previous rule is when an incorrect answer from further working is used **in a subsequent part**. For example, when a correct exact value is followed by an incorrect decimal approximation in the first part and this approximation is then used in the second part. In this situation, award **FT** marks as appropriate but do not award the final **A1** in the first part. Examples:

	Correct answer seen	Further working seen	Any FT issues?	Action
1.	$8\sqrt{2}$	5.65685... (incorrect decimal value)	No. Last part in question.	Award A1 for the final mark (condone the incorrect further working)
2.	$\frac{35}{72}$	0.468111... (incorrect decimal value)	Yes. Value is used in subsequent parts.	Award A0 for the final mark (and full FT is available in subsequent parts)

3 Implied marks

Implied marks appear in **brackets e.g. (M1)**, and can only be awarded if **correct** work is seen or implied by subsequent working/answer.

4 Follow through marks (only applied after an error is made)

Follow through (**FT**) marks are awarded where an incorrect answer from one **part** of a question is used correctly in **subsequent** part(s) (e.g. incorrect value from part (a) used in part (d) or incorrect value from part (c)(i) used in part (c)(ii)). Usually, to award **FT** marks, **there must be working present** and not just a final answer based on an incorrect answer to a previous part. However, if all the marks awarded in a subsequent part are for the answer or are implied, then **FT** marks should be awarded for *their* correct answer, even when working is not present.

For example: following an incorrect answer to part (a) that is used in subsequent parts, where the markscheme for the subsequent part is **(M1)A1**, it is possible to award full marks for *their* correct answer, **without working being seen**. For longer questions where all but the answer marks are implied this rule applies but may be overwritten by a **Note** in the Markscheme.

- Within a question part, once an **error** is made, no further **A** marks can be awarded for work which uses the error, but **M** marks may be awarded if appropriate.
- If the question becomes much simpler because of an error then use discretion to award fewer **FT** marks, by reflecting on what each mark is for and how that maps to the simplified version.
- If the error leads to an inappropriate value (e.g. probability greater than 1, $\sin \theta = 1.5$, non-integer value where integer required), do not award the mark(s) for the final answer(s).
- The markscheme may use the word “their” in a description, to indicate that candidates may be using an incorrect value.
- If the candidate’s answer to the initial question clearly contradicts information given in the question, it is not appropriate to award any **FT** marks in the subsequent parts. This includes when candidates fail to complete a “show that” question correctly, and then in subsequent parts use their incorrect answer rather than the given value.
- Exceptions to these **FT** rules will be explicitly noted on the markscheme.
- If a candidate makes an error in one part but gets the correct answer(s) to subsequent part(s), award marks as appropriate, unless the command term was “Hence”.

5 Mis-read

If a candidate incorrectly copies values or information from the question, this is a mis-read (**MR**). A candidate should be penalized only once for a particular misread. Use the **MR** stamp to indicate that this has been a misread and do not award the first mark, even if this is an **M** mark, but award all others as appropriate.

- If the question becomes much simpler because of the **MR**, then use discretion to award fewer marks.
- If the **MR** leads to an inappropriate value (e.g. probability greater than 1, $\sin \theta = 1.5$, non-integer value where integer required), do not award the mark(s) for the final answer(s).
- Miscopying of candidates' own work does **not** constitute a misread, it is an error.
- If a candidate uses a correct answer, to a "show that" question, to a higher degree of accuracy than given in the question, this is NOT a misread and full marks may be scored in the subsequent part.
- **MR** can only be applied when work is seen. For calculator questions with no working and incorrect answers, examiners should **not** infer that values were read incorrectly.

6 Alternative methods

Candidates will sometimes use methods other than those in the markscheme. Unless the question specifies a method, other correct methods should be marked in line with the markscheme. If the command term is 'Hence' and not 'Hence or otherwise' then alternative methods are not permitted unless covered by a note in the mark scheme.

- Alternative methods for complete questions are indicated by **METHOD 1**, **METHOD 2**, etc.
- Alternative solutions for parts of questions are indicated by **EITHER . . . OR**.

7 Alternative forms

Unless the question specifies otherwise, **accept** equivalent forms.

- As this is an international examination, accept all alternative forms of **notation** for example 1.9 and 1,9 or 1000 and 1,000 and 1.000.
- Do not accept final answers written using calculator notation. However, **M** marks and intermediate **A** marks can be scored, when presented using calculator notation, provided the evidence clearly reflects the demand of the mark.
- In the markscheme, equivalent **numerical** and **algebraic** forms will generally be written in brackets immediately following the answer.
- In the markscheme, some **equivalent** answers will generally appear in brackets. Not all equivalent notations/answers/methods will be presented in the markscheme and examiners are asked to apply appropriate discretion to judge if the candidate work is equivalent.

8 Format and accuracy of answers

If the level of accuracy is specified in the question, a mark will be linked to giving the answer to the required accuracy. If the level of accuracy is not stated in the question, the general rule applies to final answers: *unless otherwise stated in the question all numerical answers must be given exactly or correct to three significant figures.*

Where values are used in subsequent parts, the markscheme will generally use the exact value, however candidates may also use the correct answer in subsequent parts. The markscheme will often explicitly include the subsequent values that come “*from the use of 3 sf values*”.

Simplification of final answers: Candidates are advised to give final answers using good mathematical form. In general, for an **A** mark to be awarded, arithmetic should be completed, and

any values that lead to integers should be simplified; for example, $\sqrt{\frac{25}{4}}$ should be written as $\frac{5}{2}$.

An exception to this is simplifying fractions, where lowest form is not required (although the numerator and the denominator must be integers); for example, $\frac{10}{4}$ may be left in this form or

written as $\frac{5}{2}$. However, $\frac{10}{5}$ should be written as 2, as it simplifies to an integer.

Algebraic expressions should be simplified by completing any operations such as addition and multiplication, e.g. $4e^{2x} \times e^{3x}$ should be simplified to $4e^{5x}$, and $4e^{2x} \times e^{3x} - e^{4x} \times e^x$ should be simplified to $3e^{5x}$. Unless specified in the question, expressions do not need to be factorized, nor do factorized expressions need to be expanded, so $x(x+1)$ and $x^2 + x$ are both acceptable.

Please note: intermediate **A** marks do NOT need to be simplified.

9 Calculators

A GDC is required for this paper, but If you see work that suggests a candidate has used any calculator not approved for IB DP examinations (eg CAS enabled devices), please follow the procedures for malpractice.

10. Presentation of candidate work

Crossed out work: If a candidate has drawn a line through work on their examination script, or in some other way crossed out their work, do not award any marks for that work unless an explicit note from the candidate indicates that they would like the work to be marked.

More than one solution: Where a candidate offers two or more different answers to the same question, an examiner should only mark the first response unless the candidate indicates otherwise. If the layout of the responses makes it difficult to judge, examiners should apply appropriate discretion to judge which is “first”.



1. (a) The favourite breakfast/berry (of adults) is independent of (their) income (level). **A1** [1 mark]

(b) $\chi^2 = 2.27$ (2.26821...) **A2** [2 marks]

(c) **EITHER**
 $2.27 < 7.78$ **OR** $2.27 < \text{critical value}$ **R1**
OR
 $0.687 > 0.1$ (using p -value)

THEN

(Do not reject H_0)

Insufficient evidence (at the 10% significance level) that the favourite berry depends on income level. **A1**

Note: Do not award **R0A1**. Accept " χ^2 " in place of their "2.27", provided an answer was seen in part (b). Their conclusion must be consistent with their χ^2 (or a correct p -value) and their hypothesis.

[2 marks]
Total [5 marks]

2. (a) $71e^{-0.0514(16)} + 23$ **(M1)**

54.2 °C (54.1956...) **A1** [2 marks]

(b) 23 °C **A1** [1 mark]

(c) $50 = 71e^{-0.0514(k)} + 23$ **(M1)**

$k = 18.8 \left(\frac{-5000}{257} \ln \left(\frac{27}{71} \right), 18.8101... \right)$ **A1**

Note: Award **M1** for a sketch showing a point of intersection between the exponential function and $y = 50$.

[2 marks]
Total [5 marks]

3. (a) $\sin(21^\circ) = \frac{17}{BF}$ (M1)

$BF = 47.4 \text{ m (47.4372...)}$ A1

[2 marks]

(b) **EITHER**

$BE = \sqrt{47.4372...^2 + 44^2} = 64.7015...$ (A1)

$\sin^{-1}\left(\frac{17}{BE}\right)$ (M1)

$= 15.2^\circ \text{ (15.2329...}^\circ) \text{ (or 0.266 radians (0.265866...))}$ A1

OR

$AD = \sqrt{47.4372...^2 - 17^2} = 44.2865...$

$DB = \sqrt{64.7015...^2 + 44^2} = 62.4832...$ (A1)

$\tan^{-1}\left(\frac{17}{62.4832...}\right)$ (M1)

$= 15.2^\circ \text{ (15.2329...}^\circ) \text{ (or 0.266 radians (0.265866...))}$ A1

[3 marks]

Total [5 marks]

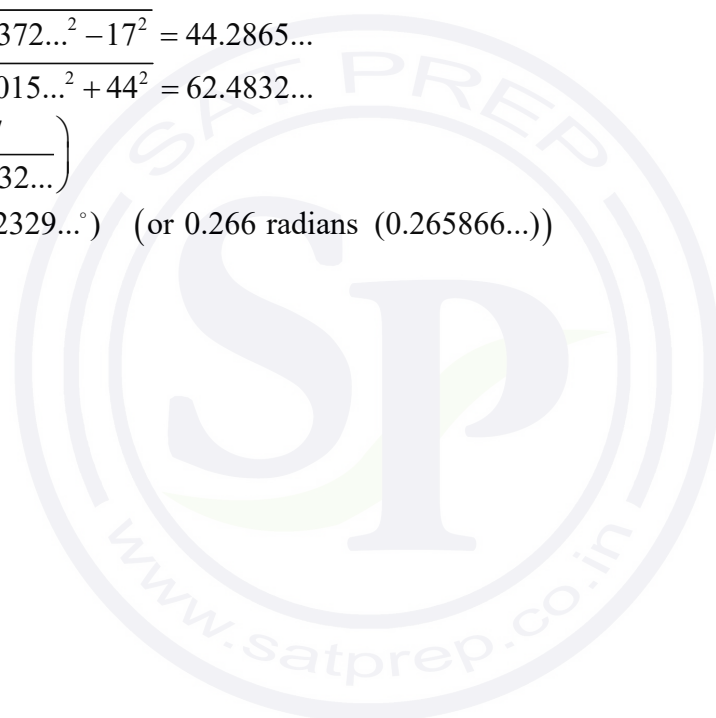

4. (a)

$$\begin{matrix} & \text{S} & \text{A} & \text{B} & \text{C} & \text{D} & \text{T} \\ \text{S} & \left(\begin{array}{cccccc} 0 & 1 & 1 & 1 & \boxed{2} & 0 \end{array} \right) \\ \text{A} & \left(\begin{array}{cccccc} 1 & 0 & 1 & 1 & \boxed{0} & 0 \end{array} \right) \\ \text{B} & \left(\begin{array}{cccccc} 1 & 1 & 0 & 1 & 1 & 1 \end{array} \right) \\ \text{C} & \left(\begin{array}{cccccc} 1 & 1 & 1 & 0 & 1 & 1 \end{array} \right) \\ \text{D} & \left(\begin{array}{cccccc} \boxed{2} & \boxed{0} & 1 & 1 & 0 & 1 \end{array} \right) \\ \text{T} & \left(\begin{array}{cccccc} 0 & 0 & 1 & 1 & 1 & 0 \end{array} \right) \end{matrix}$$

SD = DS = 2
AD = DA = 0

A1
A1
[2 marks]

- (b) attempt to calculate at least one of M^2 , M^3 and M^4
attempt to calculate all of M^2 , M^3 and M^4
finding at least one of the top right entries, 4, 10, 64
78 walks

(M1)
(M1)
(A1)
A1

Note: If SD = DS = 1 is their answer in part (a), their **FT** answer is (3+8+41=) 52 walks.

[4 marks]

- (c) because some of the walks will pass through T, before returning to T

R1
[1 mark]
Total [7 marks]

5. (a) $0.5 \times 0.1 + 0.4 \times 0.4 + 0.1 \times 0.5$

(M1)(M1)(M1)

Note: Award **M1** for 0.5×0.1 or 0.1×0.5 , **M1** for 0.4×0.4 , **M1** for adding three correct products.

0.26

A1
[4 marks]

(b) $0 = -8 \times 0.5 + 4 \times 0.4 + 0.1k$

(M1)(M1)

Note: Award **M1** for correct substitution into the formula for expected value, award **M1** for the expected value formula equated to zero.

(k =) 24 (points)

A1
[3 marks]
Total [7 marks]

6. (a) 78 A1
[1 mark]
- (b) (i) 65 A1
- (ii) **EITHER**
 (period =) 16 (could be seen on sketch) (M1)
 $b = \frac{2\pi}{16}$ **OR** $b = \frac{360^\circ}{16}$
 (b =) 0.393 $\left(0.392699\dots, \frac{\pi}{8}\right)$ **OR** (b =) 22.5° A1
- OR**
 $143 = 65 \sin(4b) + 78$ (M1)
 (sin(4b) = 1)
 $(4b = \frac{\pi}{2}$ **OR** $4b = 90^\circ)$
 (b =) 0.393 $\left(0.392699\dots, \frac{\pi}{8}\right)$ **OR** (b =) 22.5° A1
- [3 marks]**
- (c) 13 A1
- Note:** Apply follow through marking only if their final answer is positive.
- [1 mark]**
- (d) (b =) 0.196 $\left(0.196349\dots, \frac{\pi}{16}\right)$ **OR** (b =) 11.3° (11.25°) A1
- [1 mark]**
Total [6 marks]

7. (a) $I\% = 7.5$
 $PV = \mp 800$
 $PMT = \mp 500$
 $FV = \pm 10\,000$
 $P/Y = 12$
 $C/Y = 12$

(M1)(A1)

Note: Award **M1** for an attempt to use a financial app in their technology (e.g. at least four rows seen, but not necessarily correct), award **A1** for $PMT = -500$ or $PMT = 500$, with same sign to PV and opposite sign to FV.

17.3070...
 $(k =) 18$

(A1)
A1

Note: Award **(M0)(A0)(A0)A0** for a final answer of 17 with no working. The final answer must be an integer.

[4 marks]

- (b) $10389 - (18 \times 500 + 800)$ **OR** $10389 - (9800)$

(A1)(M1)

Note: Award **(A1)** for 10389 (10389.38...) seen. Award **(M1)** for subtraction of their $(18 \times 500 + 800)$ from FV. **FT** from their value of k . Award **A0M1A0** for $10\,000 - (18 \times 500 + 800)$. Do not award the final **A1FT** if their answer is negative.

589 EUR

A1

Note: Final answer must be to the nearest euro.

[3 marks]
Total [7 marks]

8. (a) setting up at least two simultaneous equations
 $p = -0.8$ **OR** $q = 3.6$
 M has coordinates $(1.6, -2.6, 8.2)$

(M1)

(A1)

A1

[3 marks]

- (b) using vectors $\begin{pmatrix} 3 \\ 2 \\ 1 \end{pmatrix}$ and $\begin{pmatrix} 1 \\ -1 \\ 2 \end{pmatrix}$

(M1)

$$\begin{pmatrix} 3 \\ 2 \\ 1 \end{pmatrix} \cdot \begin{pmatrix} 1 \\ -1 \\ 2 \end{pmatrix} = 3$$

(A1)

$$\cos \theta = \frac{\begin{pmatrix} 3 \\ 2 \\ 1 \end{pmatrix} \cdot \begin{pmatrix} 1 \\ -1 \\ 2 \end{pmatrix}}{\sqrt{3^2 + 2^2 + 1^2} \sqrt{1^2 + (-1)^2 + 2^2}} \quad \left(\cos \theta = \frac{3}{\sqrt{14}\sqrt{6}} \right)$$

(M1)

Note: Accept correct use of vector product.

$$(\theta =) 1.24 \text{ radians } (1.23732\dots) \quad (70.9^\circ \quad (70.8933\dots))$$

A1

[4 marks]

Total [7 marks]

9. (a) attempt to find $\det(M)$ (M1)
 $= 14$
 $(12 \times 14) = 168 \text{ cm}^2$ A1
[2 marks]

- (b) let X have coordinates (x, y)

METHOD 1

$$M \begin{pmatrix} x \\ y \end{pmatrix} = \begin{pmatrix} 2t-3 \\ 6-5t \end{pmatrix} \quad \text{(M1)}$$

$$\begin{pmatrix} x \\ y \end{pmatrix} = M^{-1} \begin{pmatrix} 2t-3 \\ 6-5t \end{pmatrix} \quad \text{(A1)}$$

$$M^{-1} = \frac{1}{14} \begin{pmatrix} 1 & 4 \\ -3 & 2 \end{pmatrix} \quad \text{A1}$$

$$\begin{pmatrix} x \\ y \end{pmatrix} = \frac{1}{14} \begin{pmatrix} 2t-3+24-20t \\ -6t+9+12-10t \end{pmatrix} \quad \text{(M1)}$$

$$\begin{pmatrix} x \\ y \end{pmatrix} = \frac{1}{14} \begin{pmatrix} 21-18t \\ 21-16t \end{pmatrix} \quad \text{OR} \quad \left(\frac{21-18t}{14}, \frac{21-16t}{14} \right) \quad \text{A1A1}$$

METHOD 2

writing two simultaneous equations (M1)

$$2x - 4y = 2t - 3 \quad \text{(A1)}$$

$$3x + y = 6 - 5t \quad \text{(A1)}$$

attempting to solve the equations (M1)

$$(x, y) = \left(\frac{3}{2} - \frac{9t}{7}, \frac{3}{2} - \frac{8t}{7} \right) \quad \text{A1A1}$$

[6 marks]

Total [8 marks]

10. (a) $m = 1 - 2.5 \log_{10}(0.0525)$ (M1)
 $= 4.20$ (4.19960...) A1
 [2 marks]

- (b) attempt to solve $7 = 1 - 2.5 \log_{10}(b)$ (M1)

Note: Accept a sketch from their GDC as an attempt to solve $7 = 1 - 2.5 \log_{10}(b)$.

$b = 0.00398$ (0.00398107...) A1
 [2 marks]

- (c) $-3.2 = (1 - 2.5 \log_{10}(b_n)) - (1 - 2.5 \log_{10}(b_p))$ M1

$-3.2 = -2.5 \log_{10}\left(\frac{b_n}{b_p}\right)$ A1

$\frac{b_n}{b_p} = 19.1$ (19.0546...) A1

[3 marks]
 Total [7 marks]

11. (a) $y = -0.00855x^3 - 0.234x^2 - 0.225x + 3.20$ A2
 $(y = -0.00854819...x^3 - 0.234002...x^2 - 0.224884...x + 3.20056...)$

Note: Award **A0A1** for at least two terms correct.

[2 marks]

- (b) $y(2x)$ (for horizontal stretch) (A1)

attempt to stretch vertically by factor $\frac{1}{2}$ (M1)

$y = 0.0332x^3 - 0.15x^2 - 0.58x$ (+1.1) A1

Note: Award **A0M1A0** for a vertical stretch, factor 2. Although a d value of 1.1 is preferred, technically this value can be wrong/omitted and the question is still answered (hence it is presented in brackets).

[3 marks]
 Total [5 marks]

12. (a)

Description	Phase portrait
$\lambda_1 = 2$ with eigenvector $\begin{pmatrix} 2 \\ 1 \end{pmatrix}$ and $\lambda_2 = 3$ with eigenvector $\begin{pmatrix} 1 \\ -1 \end{pmatrix}$	D
$\lambda_1 = 2$ with eigenvector $\begin{pmatrix} 2 \\ 1 \end{pmatrix}$ and $\lambda_2 = -3$ with eigenvector $\begin{pmatrix} 1 \\ -1 \end{pmatrix}$	C
$\lambda_1 = -2$ with eigenvector $\begin{pmatrix} 2 \\ 1 \end{pmatrix}$ and $\lambda_2 = 3$ with eigenvector $\begin{pmatrix} 1 \\ -1 \end{pmatrix}$	B

A1A1A1

[3 marks]

(b)

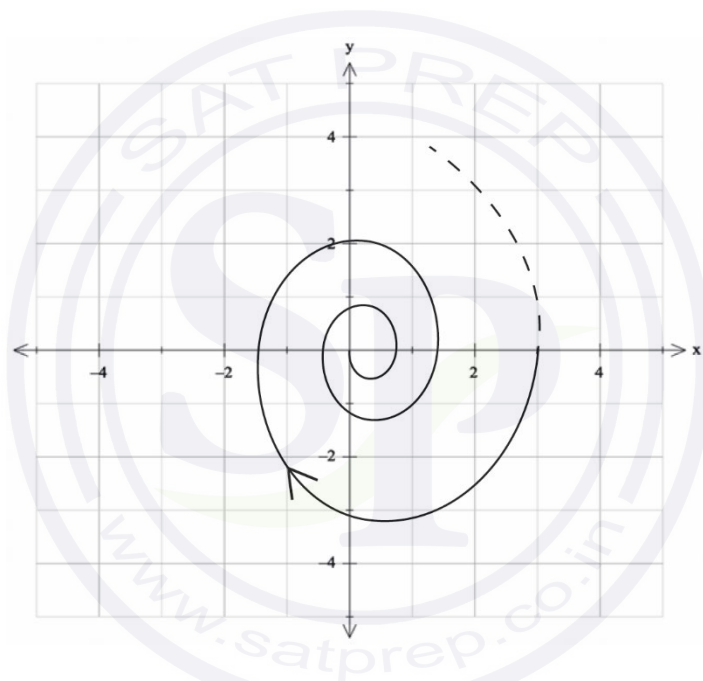

spiral (crossing x -axis at least twice), centre at origin
 arrow indicating clockwise, passing through or starting from $(3, 0)$

A1
A1
[2 marks]
Total [5 marks]

13. (a) Gradient = $\frac{14.9+1.3}{6}$ (= 2.7) (M1)
 $\log_{10} Q = 2.7P - 1.3$ (A1)
 $Q = 10^{2.7P-1.3}$ OR $Q = 0.0501 \times 10^{2.7P}$ (= 0.0501187... $\times 10^{2.7P}$) A1
 [3 marks]
- (b) $\ln R$ on one axis and Q on the other axis A1
 [1 mark]
- (c) $\log_{10}(4.3 \ln R + 12.1) = 2.7P - 1.3$ OR $10^{2.7P-1.3} = 4.3 \ln R + 12.1$ (M1)
 $P = \frac{\log_{10}(4.3 \ln R + 12.1) + 1.3}{2.7}$ A1
 [2 marks]
 Total [6 marks]

14. (a) attempt to use product rule (M1)
 $a = 2t^2 \cos(t^2) + \sin(t^2)$ A1
 [2 marks]
- (b) graph of a (M1)
 126 (ms⁻²) (125.699...) A1
 [2 marks]
- (c) attempt at integration by substitution or inspection (M1)
 $s = -\frac{1}{2} \cos(t^2) (+c)$ A1
 $(s = 0 \text{ when } t = 0) \Rightarrow c = \frac{1}{2}$ A1
 $\left(s = -\frac{1}{2} \cos(t^2) + \frac{1}{2} \right)$
 [3 marks]
- (d) $\cos(t^2) \leq 1$ A1
 $-\frac{1}{2} \cos(t^2) \geq -\frac{1}{2}$
 so $\frac{1}{2} - \frac{1}{2} \cos(t^2) \geq 0$ R1
 hence the particle never has a negative displacement. AG

Note: Do not accept reasoning based on a sketch of the graph.

[2 marks]
 Total [9 marks]

15. EITHER

$$q_{n+1} = q_n + 0.1 \left(\frac{dq}{dt} \right)_n$$

$$\left(\frac{dq}{dt} \right)_{n+1} = \left(\frac{dq}{dt} \right)_n + 0.1 \left(\frac{d^2q}{dt^2} \right)_n \quad \text{(M1)}$$

OR

let $\frac{dq}{dt} = y$

$$q_{n+1} = q_n + 0.1y_n$$

$$y_{n+1} = y_n + 0.1 \left(\frac{dy}{dt} \right)_n \quad \text{(M1)}$$

THEN

EITHER

$$\frac{dy}{dt} = 200 - 5y - 20q \quad \text{(A1)}$$

OR

$$\frac{d^2q}{dt^2} = 200 - 5 \frac{dq}{dt} - 20q \quad \text{(A1)}$$

THEN

evidence of using Euler's method (e.g.) (M1)

0	1	8	140
0.1	1.8	22	54

maximum charge = 12.7 (Coulombs, at $t = 0.7$) A2

Note: Award **A0A1** for a final answer of 10.8, from reading the value at $t = 1$.

Total [5 marks]

16. (a) (let p be the probability of a student choosing healthy options)
 $H_0: p = 0.3$
 $H_1: p > 0.3$

A1

A1

Note: Award **A0A1** for correct hypotheses with μ in place of p .
 Accept equivalent hypotheses in words.

[2 marks]

- (b) a type I error is rejecting H_0 when H_0 is true
 (let N = number of students choosing a healthy option)
 $N \sim B(80, 0.3)$
 $P(31 \leq N \leq 80)$ **OR** $P(N \geq 31)$ **OR** $1 - P(N \leq 30)$

(M1)

(M1)

Note: Do not accept the use of the Normal approximation.

0.0587 (0.0587481...)

A1

[3 marks]

- (c) a type II error is accepting H_0 when H_0 is not true
 $N \sim B(80, 0.4)$
 $P(0 \leq N \leq 30)$ **OR** $P(N \leq 30)$
 0.369 (0.368726...)

(M1)

(M1)

A1

[3 marks]

Total [8 marks]

17. (a) $D = S - R$

METHOD 1

$= \operatorname{Re}(1.15e^{(0.0165t-2.97)i}) - \operatorname{Re}(1.08e^{(0.0165t+0.413)i}) \quad (+18.9 - 4.94) \quad \text{(M1)(A1)}$

$= \operatorname{Re}(e^{0.0165ti}(1.15e^{-2.97i} - 1.08e^{0.413i})) \quad (+13.96) \quad \text{(M1)}$

$= \operatorname{Re}(e^{0.0165ti}(2.21379\dots e^{-2.85310\dots i})) \quad (+13.96) \quad \text{(A1)}$

$= 2.21\cos(0.0165t - 2.85) + 13.96 \quad (2.21379\dots\cos(0.0165t - 2.85310\dots) + 13.96)$

A1A1

$(a = 2.21, b = -2.85, c = 13.96)$

Note: Award **A1** for $2.21\cos(0.0165t - 2.85)$ and **A1** for “+13.96”. The **A1** for 13.96 is independent of the previous marks.

METHOD 2

$c = 13.9 - 4.94\dots = 13.96 \quad \text{A1}$

using a graph of $D \quad \text{M1}$

maximum $(172.915\dots, 16.1738\dots) \quad \text{(A1)}$

minimum $(-17.4842\dots, 11.7462\dots) \quad \text{(A1)}$

EITHER

amplitude $16.1738\dots - 11.7462\dots = 4.4276\dots$

$a = 2.21 \quad (2.2138\dots) \quad \text{A1}$

OR

$a = 16.1738\dots - 13.96 = 2.21 \quad (2.2138\dots) \quad \text{A1}$

THEN

EITHER

when $t = 0, D = 11.8377\dots$

$11.8377\dots = 2.2138\cos(b) + 13.96$

$b = -2.85 \quad (2.85309\dots) \quad \text{A1}$

OR

$b = -0.0165 \times 172.915\dots = -2.85 \quad (2.85309\dots) \quad \text{A1}$

[6 marks]

(b) $16.2 \quad (16.1737\dots)$ hours on day 173 **A1A1**

Note: Accept an answer of “day 172” for the second **A1**.

[2 marks]

Total [8 marks]

Markscheme

May 2022

**Mathematics:
applications and interpretation**

Higher level

Paper 1

© International Baccalaureate Organization 2022

All rights reserved. No part of this product may be reproduced in any form or by any electronic or mechanical means, including information storage and retrieval systems, without the prior written permission from the IB. Additionally, the license tied with this product prohibits use of any selected files or extracts from this product. Use by third parties, including but not limited to publishers, private teachers, tutoring or study services, preparatory schools, vendors operating curriculum mapping services or teacher resource digital platforms and app developers, whether fee-covered or not, is prohibited and is a criminal offense.

More information on how to request written permission in the form of a license can be obtained from <https://ibo.org/become-an-ib-school/ib-publishing/licensing/applying-for-a-license/>.

© Organisation du Baccalauréat International 2022

Tous droits réservés. Aucune partie de ce produit ne peut être reproduite sous quelque forme ni par quelque moyen que ce soit, électronique ou mécanique, y compris des systèmes de stockage et de récupération d'informations, sans l'autorisation écrite préalable de l'IB. De plus, la licence associée à ce produit interdit toute utilisation de tout fichier ou extrait sélectionné dans ce produit. L'utilisation par des tiers, y compris, sans toutefois s'y limiter, des éditeurs, des professeurs particuliers, des services de tutorat ou d'aide aux études, des établissements de préparation à l'enseignement supérieur, des fournisseurs de services de planification des programmes d'études, des gestionnaires de plateformes pédagogiques en ligne, et des développeurs d'applications, moyennant paiement ou non, est interdite et constitue une infraction pénale.

Pour plus d'informations sur la procédure à suivre pour obtenir une autorisation écrite sous la forme d'une licence, rendez-vous à l'adresse <https://ibo.org/become-an-ib-school/ib-publishing/licensing/applying-for-a-license/>.

© Organización del Bachillerato Internacional, 2022

Todos los derechos reservados. No se podrá reproducir ninguna parte de este producto de ninguna forma ni por ningún medio electrónico o mecánico, incluidos los sistemas de almacenamiento y recuperación de información, sin la previa autorización por escrito del IB. Además, la licencia vinculada a este producto prohíbe el uso de todo archivo o fragmento seleccionado de este producto. El uso por parte de terceros —lo que incluye, a título enunciativo, editoriales, profesores particulares, servicios de apoyo académico o ayuda para el estudio, colegios preparatorios, desarrolladores de aplicaciones y entidades que presten servicios de planificación curricular u ofrezcan recursos para docentes mediante plataformas digitales—, ya sea incluido en tasas o no, está prohibido y constituye un delito.

En este enlace encontrará más información sobre cómo solicitar una autorización por escrito en forma de licencia: <https://ibo.org/become-an-ib-school/ib-publishing/licensing/applying-for-a-license/>.

Instructions to Examiners

Abbreviations

- M** Marks awarded for attempting to use a correct **Method**.
- A** Marks awarded for an **Answer** or for **Accuracy**; often dependent on preceding **M** marks.
- R** Marks awarded for clear **Reasoning**.
- AG** Answer given in the question and so no marks are awarded.
- FT** Follow through. The practice of awarding marks, despite candidate errors in previous parts, for their correct methods/answers using incorrect results.

Using the markscheme

1 General

Award marks using the annotations as noted in the markscheme eg **M1**, **A2**.

2 Method and Answer/Accuracy marks

- Do **not** automatically award full marks for a correct answer; all working **must** be checked, and marks awarded according to the markscheme.
- It is generally not possible to award **M0** followed by **A1**, as **A** mark(s) depend on the preceding **M** mark(s), if any.
- Where **M** and **A** marks are noted on the same line, e.g. **M1A1**, this usually means **M1** for an **attempt** to use an appropriate method (e.g. substitution into a formula) and **A1** for using the **correct** values.
- Where there are two or more **A** marks on the same line, they may be awarded independently; so if the first value is incorrect, but the next two are correct, award **A0A1A1**.
- Where the markscheme specifies **A3**, **M2** etc., do **not** split the marks, unless there is a note.
- The response to a “show that” question does not need to restate the **AG** line, unless a **Note** makes this explicit in the markscheme.
- Once a correct answer to a question or part question is seen, ignore further working even if this working is incorrect and/or suggests a misunderstanding of the question. This will encourage a uniform approach to marking, with less examiner discretion. Although some candidates may be advantaged for that specific question item, it is likely that these candidates will lose marks elsewhere too.
- An exception to the previous rule is when an incorrect answer from further working is used **in a subsequent part**. For example, when a correct exact value is followed by an incorrect decimal approximation in the first part and this approximation is then used in the second part. In this situation, award **FT** marks as appropriate but do not award the final **A1** in the first part. Examples:

	Correct answer seen	Further working seen	Any FT issues?	Action
1.	$8\sqrt{2}$	5.65685... (incorrect decimal value)	No. Last part in question.	Award A1 for the final mark (condone the incorrect further working)
2.	$\frac{35}{72}$	0.468111... (incorrect decimal value)	Yes. Value is used in subsequent parts.	Award A0 for the final mark (and full FT is available in subsequent parts)

3 Implied marks

Implied marks appear in **brackets e.g. (M1)**, and can only be awarded if **correct** work is seen or implied by subsequent working/answer.

4 Follow through marks (only applied after an error is made)

Follow through (**FT**) marks are awarded where an incorrect answer from one **part** of a question is used correctly in **subsequent** part(s) (e.g. incorrect value from part (a) used in part (d) or incorrect value from part (c)(i) used in part (c)(ii)). Usually, to award **FT** marks, **there must be working present** and not just a final answer based on an incorrect answer to a previous part. However, if all the marks awarded in a subsequent part are for the answer or are implied, then **FT** marks should be awarded for *their* correct answer, even when working is not present.

For example: following an incorrect answer to part (a) that is used in subsequent parts, where the markscheme for the subsequent part is **(M1)A1**, it is possible to award full marks for *their* correct answer, **without working being seen**. For longer questions where all but the answer marks are implied this rule applies but may be overwritten by a **Note** in the Markscheme.

- Within a question part, once an **error** is made, no further **A** marks can be awarded for work which uses the error, but **M** marks may be awarded if appropriate.
- If the question becomes much simpler because of an error then use discretion to award fewer **FT** marks, by reflecting on what each mark is for and how that maps to the simplified version.
- If the error leads to an inappropriate value (e.g. probability greater than 1, $\sin \theta = 1.5$, non-integer value where integer required), do not award the mark(s) for the final answer(s).
- The markscheme may use the word “their” in a description, to indicate that candidates may be using an incorrect value.
- If the candidate’s answer to the initial question clearly contradicts information given in the question, it is not appropriate to award any **FT** marks in the subsequent parts. This includes when candidates fail to complete a “show that” question correctly, and then in subsequent parts use their incorrect answer rather than the given value.
- Exceptions to these **FT** rules will be explicitly noted on the markscheme.
- If a candidate makes an error in one part but gets the correct answer(s) to subsequent part(s), award marks as appropriate, unless the command term was “Hence”.

5 Mis-read

If a candidate incorrectly copies values or information from the question, this is a mis-read (**MR**). A candidate should be penalized only once for a particular misread. Use the **MR** stamp to indicate that this has been a misread and do not award the first mark, even if this is an **M** mark, but award all others as appropriate.

- If the question becomes much simpler because of the **MR**, then use discretion to award fewer marks.
- If the **MR** leads to an inappropriate value (e.g. probability greater than 1, $\sin \theta = 1.5$, non-integer value where integer required), do not award the mark(s) for the final answer(s).
- Miscopying of candidates' own work does **not** constitute a misread, it is an error.
- If a candidate uses a correct answer, to a "show that" question, to a higher degree of accuracy than given in the question, this is NOT a misread and full marks may be scored in the subsequent part.
- **MR** can only be applied when work is seen. For calculator questions with no working and incorrect answers, examiners should **not** infer that values were read incorrectly.

6 Alternative methods

Candidates will sometimes use methods other than those in the markscheme. Unless the question specifies a method, other correct methods should be marked in line with the markscheme. If the command term is 'Hence' and not 'Hence or otherwise' then alternative methods are not permitted unless covered by a note in the mark scheme.

- Alternative methods for complete questions are indicated by **METHOD 1**, **METHOD 2**, etc.
- Alternative solutions for parts of questions are indicated by **EITHER . . . OR**.

7 Alternative forms

Unless the question specifies otherwise, **accept** equivalent forms.

- As this is an international examination, accept all alternative forms of **notation** for example 1.9 and 1,9 or 1000 and 1,000 and 1.000.
- Do not accept final answers written using calculator notation. However, **M** marks and intermediate **A** marks can be scored, when presented using calculator notation, provided the evidence clearly reflects the demand of the mark.
- In the markscheme, equivalent **numerical** and **algebraic** forms will generally be written in brackets immediately following the answer.
- In the markscheme, some **equivalent** answers will generally appear in brackets. Not all equivalent notations/answers/methods will be presented in the markscheme and examiners are asked to apply appropriate discretion to judge if the candidate work is equivalent.

8 Format and accuracy of answers

If the level of accuracy is specified in the question, a mark will be linked to giving the answer to the required accuracy. If the level of accuracy is not stated in the question, the general rule applies to final answers: *unless otherwise stated in the question all numerical answers must be given exactly or correct to three significant figures.*

Where values are used in subsequent parts, the markscheme will generally use the exact value, however candidates may also use the correct answer in subsequent parts. The markscheme will often explicitly include the subsequent values that come “*from the use of 3 sf values*”.

Simplification of final answers: Candidates are advised to give final answers using good mathematical form. In general, for an **A** mark to be awarded, arithmetic should be completed, and

any values that lead to integers should be simplified; for example, $\sqrt{\frac{25}{4}}$ should be written as $\frac{5}{2}$.

An exception to this is simplifying fractions, where lowest form is not required (although the numerator and the denominator must be integers); for example, $\frac{10}{4}$ may be left in this form or

written as $\frac{5}{2}$. However, $\frac{10}{5}$ should be written as 2, as it simplifies to an integer.

Algebraic expressions should be simplified by completing any operations such as addition and multiplication, e.g. $4e^{2x} \times e^{3x}$ should be simplified to $4e^{5x}$, and $4e^{2x} \times e^{3x} - e^{4x} \times e^x$ should be simplified to $3e^{5x}$. Unless specified in the question, expressions do not need to be factorized, nor do factorized expressions need to be expanded, so $x(x+1)$ and $x^2 + x$ are both acceptable.

Please note: intermediate **A** marks do NOT need to be simplified.

9 Calculators

A GDC is required for this paper, but If you see work that suggests a candidate has used any calculator not approved for IB DP examinations (eg CAS enabled devices), please follow the procedures for malpractice.

10. Presentation of candidate work

Crossed out work: If a candidate has drawn a line through work on their examination script, or in some other way crossed out their work, do not award any marks for that work unless an explicit note from the candidate indicates that they would like the work to be marked.

More than one solution: Where a candidate offers two or more different answers to the same question, an examiner should only mark the first response unless the candidate indicates otherwise. If the layout of the responses makes it difficult to judge, examiners should apply appropriate discretion to judge which is “first”.



1. (a) $\left(\frac{17+25}{130} = \right) \frac{42}{130} \left(\frac{21}{65}, 0.323076\dots\right)$

A1

[1 mark]

(b) $\left(\frac{17}{17+25} = \right) \frac{17}{42} (0.404761\dots)$

A1A1

Note: Award **A1** for correct numerator and **A1** for correct denominator.
Award **A1A0** for working of $\frac{17}{130}$ if followed by an incorrect answer.

[2 marks]

(c) $\frac{41}{130} \times \frac{40}{129}$

A1M1

Note: Award **A1** for two correct fractions seen, **M1** for multiplying their fractions.

$$= \frac{1640}{16770} \approx 0.0978 \left(0.0977936\dots, \frac{164}{1677}\right)$$

A1

[3 marks]

Total [6 marks]

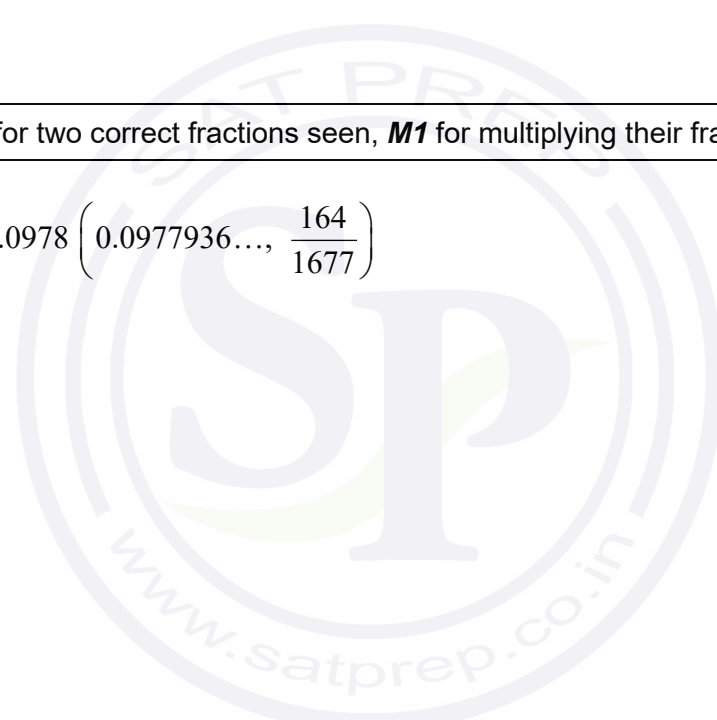

2. (a) $\sin \theta = \frac{2.1}{2.8}$ **OR** $\tan \theta = \frac{2.1}{1.85202\dots}$ **(M1)**

$(\theta =) 48.6^\circ$ (48.5903...°) **A1**
[2 marks]

(b) **METHOD 1**

$\sqrt{2.8^2 - 2.1^2}$ **OR** $2.8 \cos(48.5903\dots)$ **OR** $\frac{2.1}{\tan(48.5903\dots)}$ **(M1)**

Note: Award **M1** for attempt to use Pythagorean Theorem with 2.1 seen or for attempt to use cosine or tangent ratio.

1.85 m (1.85202...) **(A1)**

Note: Award the **M1A1** if 1.85 is seen in part (a).

$(6.4 - 1.85202\dots)$
4.55 m (4.54797...) **(A1)**

Note: Award **A1** for 4.55 or equivalent seen, either as a separate calculation or in Pythagorean Theorem.

$\sqrt{(4.54797\dots)^2 + 2.1^2}$
5.01 m (5.00939...m) **A1**

METHOD 2

attempt to use cosine rule **(M1)**

$(c^2 =) 2.8^2 + 6.4^2 - 2(2.8)(6.4) \cos(48.5903\dots)$ **(A1)(A1)**

Note: Award **A1** for 48.5903...° substituted into cosine rule formula, **A1** for correct substitution.

$(c =) 5.01$ m (5.00939...m) **A1**
[4 marks]

- (c) camera 1 is closer to the cash register than camera 2 (and both cameras are at the same height on the wall) **R1**
the larger angle of depression is from camera 1 **A1**

Note: Do not award **ROA1**. Award **ROA0** if additional calculations are completed and used in their justification, as per the question. Accept "1.85 < 4.55" or "2.8 < 5.01" as evidence for the **R1**.

[2 marks]
Total [8 marks]

3. (a) $(E(X) =) 10 \times 0.8$ (M1)
 8 (people) A1
 [2 marks]
- (b) recognition of binomial probability (M1)
 0.0881 (0.0880803...) A1
 [2 marks]
- (c) 0.8 and 6 seen **OR** 0.2 and 3 seen (A1)
 attempt to use binomial probability (M1)
 0.121 (0.120873...) A1
 [3 marks]
Total [7 marks]

4. (a) **EITHER**
 attempt to substitute 3, 4 and 7 into area of a trapezoid formula (M1)
 $(A =) \frac{1}{2}(7+4)(3)$
- OR**
 given area expressed as an integral (M1)
 $(A =) \int_{-1}^2 (6-x) dx$
- OR**
 attempt to sum area of rectangle and area of triangle (M1)
 $(A =) 4 \times 3 + \frac{1}{2} (3)(3)$
- THEN**
 16.5 (square units) A1
 [2 marks]
- (b) (i) $(A =) \int_{-1}^2 1.5x^2 - 2.5x + 3 dx$ A1A1

Note: Award **A1** for the limits $x = -1$, $x = 2$ in correct location. Award **A1** for an integral of the quadratic function, dx must be included. Do not accept “y” in place of the function, given that two equations are in the question.

- (ii) 9.75 (square units) A1
 [3 marks]
- (c) $16.5 - 9.75$ (M1)
 6.75 (square units) A1
 [2 marks]
Total [7 marks]

5. (a) *Accept any one of the following (or equivalent):*
 one minimum and one maximum point
 three x -intercepts or three roots (or zeroes)
 one point of inflexion

R1

Note: Do not accept "S shape" as a justification.

[1 mark]

(b) (i) $(d =) -5$

A1

(ii) $8 = a + b + c$
 $4 = 8a + 4b + 2c$
 $0 = 27a + 9b + 3c$

A2

Note: Award **A2** if all three equations are correct.
 Award **A1** if at least one is correct. Award **A1** for three correct equations that include the letter "d".

(iii) $a = 2, b = -12, c = 18$

A1

[4 marks]

- (c) equating found expression to zero

(M1)

$0 = 2t^3 - 12t^2 + 18t - 5$
 $t = 0.358216\dots, 1.83174\dots, 3.81003\dots$

(A1)

(so total time in debt is $3.81003\dots - 1.83174\dots + 0.358216 \approx$)
 2.34 (2.33650...) years

A1

[3 marks]

Total [8 marks]

6. (a)

$$\begin{pmatrix} 1 & 1 & 0 & 0 & 0 \\ 1 & 0 & 0 & 0 & 1 \\ 0 & 1 & 0 & 1 & 0 \\ 1 & 0 & 0 & 0 & 0 \\ 1 & 0 & 1 & 1 & 0 \end{pmatrix}$$

A2

Note: Award **A2** for the transposed matrix. Presentation in markscheme assumes columns/rows ordered A-E; accept a matrix with rows and/or columns in a different order only if appropriately communicated. Do not **FT** from part (a) into part (b).

[2 marks]

(b) raising their matrix to a power of 5

(M1)

$$M^5 = \begin{pmatrix} 17 & 9 & 2 & 3 & 5 \\ 17 & 10 & 3 & 4 & 4 \\ 13 & 6 & 2 & 2 & 4 \\ 8 & 5 & 1 & 2 & 2 \\ 18 & 11 & 2 & 4 & 5 \end{pmatrix}$$

(A1)

Note: The numbers along the diagonal are sufficient to award **M1A1**.

(the required number is $17+10+2+2+5=$) 36

A1

[3 marks]
Total [5 marks]

7. METHOD 1

$$\frac{u_1}{1-r} = 9 \quad \text{A1}$$

therefore $u_1 = 9 - 9r$

$$u_1 = 4 + u_1 r \quad \text{A1}$$

substitute or solve graphically: M1

$$9 - 9r = 4 + (9 - 9r)r \quad \text{OR} \quad \frac{4}{(1-r)^2} = 9$$

$$9r^2 - 18r + 5 = 0$$

$$r = \frac{1}{3} \quad \text{or} \quad r = \frac{5}{3}$$

only $r = \frac{1}{3}$ is possible as the sum to infinity exists R1

$$\text{then } u_1 = 9 - \left(9 \times \frac{1}{3}\right) = 6$$

$$u_3 = 6 \times \frac{1^2}{3} = \frac{2}{3} \quad \text{A1}$$

METHOD 2

$$\frac{u_1}{1-r} = 9 \quad \text{A1}$$

$$r = \frac{u_1 - 4}{u_1} \quad \text{A1}$$

attempt to solve M1

$$\frac{u_1}{1 - \left(\frac{u_1 - 4}{u_1}\right)} = 9$$

$$\frac{u_1}{\left(\frac{4}{u_1}\right)} = 9$$

$$(u_1)^2 = 36$$

$$u_1 = \pm 6$$

attempting to solve both possible sequences

6, 2, ... or -6, -10 ...

$$r = \frac{1}{3} \quad \text{or} \quad r = \frac{5}{3}$$

only $r = \frac{1}{3}$ is possible as the sum to infinity exists R1

$$u_3 = 6 \times \left(\frac{1}{3}\right)^2 = \frac{2}{3} \quad \text{A1}$$

Total [5 marks]

8. (a) $\pi \times 2^2 \times \frac{30}{360}$ (M1)
 $= 1.047 \text{ cm}^2$ A1

Note: Do not award the final mark if the answer is not correct to 4 sf.

[2 marks]

(b) attempt to substitute any two values from 1.5, 2.5, 25 or 35 into area of sector formula (M1)

$\left(\text{upper bound} = \pi \times 2.5^2 \times \frac{35}{360} = \right) 1.91 \text{ cm}^2 \text{ (1.90895...)} \quad \text{A1}$

$\left(\text{lower bound} = \pi \times 1.5^2 \times \frac{25}{360} = \right) 0.491 \text{ cm}^2 \text{ (0.490873...)} \quad \text{A1}$

Note: Given the nature of the question, accept correctly rounded **OR** correctly truncated 3 significant figure answers.

[3 marks]

(c) $\left(\left| \frac{1.047 - 1.90895...}{1.90895...} \right| \times 100 = \right) 45.2 \text{ (\%)} \text{ (45.1532...)} \quad \text{A1}$

$\left(\left| \frac{1.047 - 0.490873...}{0.490873...} \right| \times 100 = \right) 113 \text{ (\%)} \text{ (113.293...)} \quad \text{A1}$

so the largest percentage error is 113 % A1

Note: Accept 45.1 (%) (45.1428), from use of full accuracy answers. Given the nature of the question, accept correctly rounded **OR** correctly truncated 3 significant figure answers. Award **A0A1A0** if 113% is the only value found.

[3 marks]

Total [8 marks]

9. (a) $\bar{x} = 4.63$ (4.62686...) **A1**
[1 mark]

(b) $s_{n-1} = 1.098702$ **(A1)**
 $s_{n-1}^2 = 1.21$ (1.207146...) **A1**

Note: Award **A0A0** for an answer of 1.19 from biased estimate.

[2 marks]

(c) (i) $H_1: \mu > 4.4$ **A1**

(ii) **METHOD 1**
 using a z -test **(M1)**
 $p = 0.0454992\dots$ **A1**
 $p < 0.05$ **R1**
 reject null hypothesis **A1**
 (therefore there is significant evidence that the IB HL math students know more digits of π than the population in general)

Note: Do not award **R0A1**. Allow **R1A1** for consistent conclusion following on from their p -value.

METHOD 2
 using a t -test **(M1)**
 $p = 0.0478584\dots$ **A1**
 $p < 0.05$ **R1**
 reject null hypothesis **A1**
 (therefore there is significant evidence that the IB HL math students know more digits of π than the population in general)

Note: Do not award **R0A1**. Allow **R1A1** for consistent conclusion following on from their p -value.

[5 marks]
Total [8 marks]

10. (a) $y = \ln\left(\frac{1}{x-2}\right)$

an attempt to isolate x (or y if switched)

(M1)

$$e^y = \frac{1}{x-2}$$

$$x-2 = e^{-y}$$

$$x = e^{-y} + 2$$

switching x and y (seen anywhere)

M1

$$f^{-1}(x) = e^{-x} + 2$$

A1

[3 marks]

(b) sketch of $f(x)$ and $f^{-1}(x)$

(M1)

$$x = 2.12 \text{ (2.12002...)}$$

A1

[2 marks]

Total [5 marks]



11. (a) **METHOD 1** – (With FV=4000)

EITHER

N= 10
I=1.5
FV= 4000
P/Y= 1
C/Y= 1

(A1)(M1)

Note: Award **A1** for (3.5 – 2 =) 1.5 seen and **M1** for all other entries correct.

OR

$$4000 = A(1 + 0.015)^{10}$$

(A1)(M1)

Note: Award **A1** for 1.5 or 0.015 seen, **M1** for attempt to substitute into compound interest formula **and** equating to 4000.

THEN

(PV =) \$3447

A1

Note: Award **A0** if not rounded to a whole number or a negative sign given.

METHOD 2 – (With FV including inflation)

calculate FV with inflation

$$4000 \times 1.02^{10}$$

(=4875.977...)

(A1)

EITHER

$$4000 \times 1.02^{10} = PV \times 1.035^{10}$$

(A1)

OR

N= 10
I= 3.5
FV= 4875.977...
P/Y= 1
C/Y= 1

(M1)

Note: Award **M1** for *their* FV and all other entries correct.

THEN

(PV =) \$3457

A1

Note: Award **A0** if not rounded to a whole number or a negative sign given.

continued...

Question 11 continued

METHOD 3 – (Using formula to calculate real rate of return)
 (real rate of return =) 1.47058...(%) **(A1)**

EITHER
 $4000 = PV \times 1.0147058...^{10}$ **(A1)**

OR
 N= 10
 I= 1.47058...
 FV= 4000
 P/Y= 1
 C/Y= 1 **(M1)**

Note: Award **M1** for all entries correct.

THEN
 (PV =) \$3457 **A1**
[3 marks]

(b) **METHOD 1** – (Finding the future value of the investment using PV from part (a))
 N= 10
 I=3.5
 PV= 3446.66...(from Method 1) **OR** 3456.67...(from Methods 2, 3)
 P/Y= 1
 C/Y= 1 **(M1)**

Note: Award **M1** for interest rate 3.5 **and** answer to part (a) as PV.

(FV=) \$4861.87 **OR** \$4875.97 **(A1)**
 so payment required (from TVM) will be \$294 **OR** \$295 **A1**

Note: Award **A0** if a negative sign given, unless already penalized in part (a).

METHOD 2 – (Using FV)
 N= 10
 I=3.5
 PV= -1000
 FV= 4875.977...
 P/Y= 1
 C/Y= 1 **(A1)(M1)**

Note: Award **A1** for I=3.5 **and** FV= ±4875.977..., **M1** for all other entries correct **and** opposite PV and FV signs.

(PMT =) \$295 (295.393) **A1**

Note: Correct 3sf answer is 295, however accept an answer of 296 given that the context supports rounding up. Award **A0** if a negative sign given, unless already penalized in part (a).

[3 marks]
Total [6 marks]

12. (a) $P(\text{Type I error}) = P(\text{stating female when male})$
 $= P(W_{\text{Male}} > 11.5)$ (M1)
 $= 0.00135$ (0.00134996...) A1
 [2 marks]
- (b) $P(\text{Type II error}) = P(\text{stating male when female})$
 $= P(W_{\text{Female}} < 11.5)$ (M1)
 $= 0.309$ (0.308537...) A1
 [2 marks]
- (c) attempt to use the total probability (M1)
 $P(\text{error}) = 0.9 \times 0.00134996... + 0.1 \times 0.308537...$
 $= 0.0321$ (0.0320687...) A1
 [2 marks]
 Total [6 marks]

13. (a) **METHOD 1**
 recognizing that the real part is distributive (M1)
 $V_T = \text{Re}(2e^{3it} + 5e^{3it+4i})$
 $= \text{Re}(e^{3it}(2 + 5e^{4i}))$ (A1)
 (from the GDC) $2 + 5e^{4i} = 3.99088...e^{-1.89418...i}$ (A1)

Note: Accept arguments differing by 2π e.g. 4.38900...).

therefore $V_T = 3.99 \cos(3t - 1.89)$ (3.99088...cos(3t - 1.89418...)) A1

Note: Award the last **A1** for the correct values of A , B and C seen either in the required form or not. If method used is unclear and answer is partially incorrect, assume Method 2 and award appropriate marks eg. **(M1)A1A0A0** if only A value is correct.

continued...

Question 13 continued

METHOD 2

converting given expressions to cos form

(M1)

$$V_T = 2 \cos 3t + 5 \cos(3t + 4)$$

(from graph) $A = 3.99$ (3.99088...)

A1

$$V_T = 3.99 \cos(Bt + C)$$

either by considering transformations or inserting points

$$B = 3$$

A1

$$C = -1.89$$
 (-1.89418...)

A1

Note: Accept arguments differing by 2π e.g. 4.38900....

(so, $V_T = 3.99 \cos(3t - 1.89)$ (3.99088...cos(3t - 1.89418...))

Note: It is possible to have $A = 3.99$, $B = -3$ with $C = 1.89$ **OR** $A = -3.99$, $B = 3$ with $C = 1.25$
OR $A = -3.99$, $B = -3$ with $C = -1.25$ due to properties of the cosine curve.

[4 marks]

(b) maximum voltage is 3.99 (3.99088...) (units)

A1

[1 mark]

Total [5 marks]

14. $V = \pi \int_0^{10} y^2 dx$ **OR** $\pi \int_0^{10} x^2 dy$

(M1)

$$h = 2$$

$$\approx \pi \times \frac{1}{2} \times 2 \times ((4^2 + 5^2) + 2 \times (6^2 + 8^2 + 7^2 + 3^2))$$

M1A1

$$= 1120 \text{ cm}^3$$
 (1121.548...)

A1

Note: Do not award the second **M1** if the terms are not squared.

Total [4 marks]

15. (a) (one vector to the line is $\begin{pmatrix} 0 \\ c \end{pmatrix}$ therefore) $\mathbf{a} = \begin{pmatrix} 0 \\ c \end{pmatrix}$ A1
 the line goes m up for every 1 across
 (so the direction vector is) $\mathbf{b} = \begin{pmatrix} 1 \\ m \end{pmatrix}$ A1

Note: Although these are the most likely answers, many others are possible.

[2 marks]

- (b) (from GDC **OR** $6 \times 2 - 4 \times 3$) $|M| = 0$ A1

[1 mark]

(c) **METHOD 1**

$$\begin{pmatrix} X \\ Y \end{pmatrix} = \begin{pmatrix} 6 & 3 \\ 4 & 2 \end{pmatrix} \begin{pmatrix} x \\ mx+c \end{pmatrix} = \begin{pmatrix} 6x+3mx+3c \\ 4x+2mx+2c \end{pmatrix} \quad \text{M1A1}$$

$$= \begin{pmatrix} 3(2x+mx+c) \\ 2(2x+mx+c) \end{pmatrix} \quad \text{A1}$$

therefore the new line has equation $3Y = 2X$ A1
 which is independent of m or c AG

Note: The **AG** line (or equivalent) must be seen for the final **A1** line to be awarded.

METHOD 2

take two points on the line, e.g $(0, c)$ and $(1, m+c)$ M1

these map to $\begin{pmatrix} 6 & 3 \\ 4 & 2 \end{pmatrix} \begin{pmatrix} 0 \\ c \end{pmatrix} = \begin{pmatrix} 3c \\ 2c \end{pmatrix}$

and $\begin{pmatrix} 6 & 3 \\ 4 & 2 \end{pmatrix} \begin{pmatrix} 1 \\ m+c \end{pmatrix} = \begin{pmatrix} 6+3m+3c \\ 4+2m+2c \end{pmatrix}$ A1

therefore a direction vector is $\begin{pmatrix} 6+3m \\ 4+2m \end{pmatrix} = (2+m) \begin{pmatrix} 3 \\ 2 \end{pmatrix}$

(since $m \neq -2$) a direction vector is $\begin{pmatrix} 3 \\ 2 \end{pmatrix}$

the line passes through $\begin{pmatrix} 3c \\ 2c \end{pmatrix} - c \begin{pmatrix} 3 \\ 2 \end{pmatrix} = \begin{pmatrix} 0 \\ 0 \end{pmatrix}$ therefore it always has the origin as a jump-on vector A1

the vector equation is therefore $\mathbf{r} = \mu \begin{pmatrix} 3 \\ 2 \end{pmatrix}$ A1

which is independent of m or c AG

Note: The **AG** line (or equivalent) must be seen for the final **A1** line to be awarded.

continued...

Question 15 continued

METHOD 3

$$r = \begin{pmatrix} 6 & 3 \\ 4 & 2 \end{pmatrix} \left(\begin{pmatrix} 0 \\ c \end{pmatrix} + \lambda \begin{pmatrix} 1 \\ m \end{pmatrix} \right) = \begin{pmatrix} 3c \\ 2c \end{pmatrix} + \lambda \begin{pmatrix} 6+3m \\ 4+2m \end{pmatrix} \quad \text{M1A1}$$

$$= c \begin{pmatrix} 3 \\ 2 \end{pmatrix} + (2+m)\lambda \begin{pmatrix} 3 \\ 2 \end{pmatrix} \quad \text{A1}$$

$$= \mu \begin{pmatrix} 3 \\ 2 \end{pmatrix}$$

where $\mu = c + (2+m)\lambda$ is an arbitrary parameter. A1

which is independent of m or c (as μ can take any value) AG

Note: The **AG** line (or equivalent) must be seen for the final **A1** line to be awarded.

[4 marks]
Total [7 marks]

16. (a) attempt at chain rule (M1)

$$\left(v = \frac{dOP}{dt} = \right) \begin{pmatrix} 2t \cos t^2 \\ -2t \sin t^2 \end{pmatrix} \quad \text{A1}$$

[2 marks]

(b) attempt at product rule (M1)

$$a = \begin{pmatrix} 2 \cos t^2 - 4t^2 \sin t^2 \\ -2 \sin t^2 - 4t^2 \cos t^2 \end{pmatrix} \quad \text{A1}$$

METHOD 1

let $S = \sin t^2$ and $C = \cos t^2$

finding $\cos \theta$ using

$$a \cdot \vec{OP} = 2SC - 4t^2 S^2 - 2SC - 4t^2 C^2 = -4t^2 \quad \text{M1}$$

$$|\vec{OP}| = 1$$

$$|a| = \sqrt{(2C - 4t^2 S)^2 + (-2S - 4t^2 C)^2}$$

$$= \sqrt{4 + 16t^4} > 4t^2$$

if θ is the angle between them, then

$$\cos \theta = -\frac{4t^2}{\sqrt{4 + 16t^4}} \quad \text{A1}$$

so $-1 < \cos \theta < 0$ therefore the vectors are never parallel R1

continued...

Question 16 continued

METHOD 2

solve

$$\begin{pmatrix} 2 \cos t^2 - 4t^2 \sin t^2 \\ -2 \sin t^2 - 4t^2 \cos t^2 \end{pmatrix} = k \begin{pmatrix} \sin t^2 \\ \cos t^2 \end{pmatrix}$$

M1

then

$$(k =) \frac{2 \cos t^2 - 4t^2 \sin t^2}{\sin t^2} = \frac{-2 \sin t^2 - 4t^2 \cos t^2}{\cos t^2}$$

Note: Condone candidates not excluding the division by zero case here. Some might go straight to the next line.

$$2 \cos^2 t^2 - 4t^2 \cos t^2 \sin t^2 = -2 \sin^2 t^2 - 4t^2 \cos t^2 \sin t^2$$

$$2 \cos^2 t^2 + 2 \sin^2 t^2 = 0$$

$$2 = 0$$

A1

this is never true so the two vectors are never parallel

R1

METHOD 3

embedding vectors in a 3d space and taking the cross product:

M1

$$\begin{pmatrix} \sin t^2 \\ \cos t^2 \\ 0 \end{pmatrix} \times \begin{pmatrix} 2 \cos t^2 - 4t^2 \sin t^2 \\ -2 \sin t^2 - 4t^2 \cos t^2 \\ 0 \end{pmatrix} = \begin{pmatrix} 0 \\ 0 \\ -2 \sin^2 t^2 - 4t^2 \cos t^2 \sin t^2 - 2 \cos^2 t^2 + 4t^2 \cos t^2 \sin t^2 \end{pmatrix}$$

$$= \begin{pmatrix} 0 \\ 0 \\ -2 \end{pmatrix}$$

A1

since the cross product is never zero, the two vectors are never parallel

R1

[5 marks]

Total [7 marks]

17. (a) use of chain rule (M1)

$$\frac{dy}{dt} = \frac{dy}{dx} \frac{dx}{dt}$$

attempt to find $\frac{dy}{dx}$ at $x=1$ (M1)

$$0.2 = 0.04 \times \frac{dx}{dt}$$

$$\left(\frac{dx}{dt} =\right) 5 \text{ m h}^{-1} \quad \text{A1}$$

[3 marks]

(b) (i) if the position of the snail is (X, Y)

$$\text{from part (a)} \quad \frac{dX}{dt} = \frac{1}{0.04X} \frac{dY}{dt}$$

since speed is 1:

finding modulus of velocity vector and equating to 1 (M1)

$$1 = \sqrt{\left(\frac{\dot{Y}}{0.04X}\right)^2 + \dot{Y}^2} \quad \text{OR} \quad 1 = \sqrt{\dot{X}^2 + 0.0016X^2\dot{X}^2}$$

$$1 = \dot{Y}^2 \left(\frac{1}{0.0016X^2} + 1\right) \quad \text{OR} \quad 1 = \dot{X}^2(1 + 0.0016X^2)$$

$$\dot{Y} = \sqrt{\frac{1}{\frac{1}{0.08Y} + 1}} \quad \text{OR} \quad \dot{X} = \sqrt{\frac{1}{1 + 0.0016X^2}} \quad \text{(A1)}$$

$$\int_{0.02}^2 \sqrt{\frac{1}{0.08Y} + 1} dY = \int_0^T dt \quad \text{OR} \quad \int_1^{10} \sqrt{1 + 0.0016X^2} dX = \int_0^T dt \quad \text{(M1)}$$

$$T = 9.26 \text{ hours} \quad \text{A1}$$

(ii) EITHER

time for water to reach top is $\frac{2}{0.2} = 10$ hours (seen anywhere) A1

OR

or at time $t = 9.26$, height of water is $0.2 \times 9.26 = 1.852$ A1

THEN

so the water will not reach the snail AG

[5 marks]

Total [8 marks]

Markscheme

May 2022

**Mathematics:
applications and interpretation**

Higher level

Paper 1

This markscheme is **confidential** and for the exclusive use of examiners in this examination session.

It is the property of the International Baccalaureate and must **not** be reproduced or distributed to any other person without the authorization of the IB Global Centre, Cardiff.

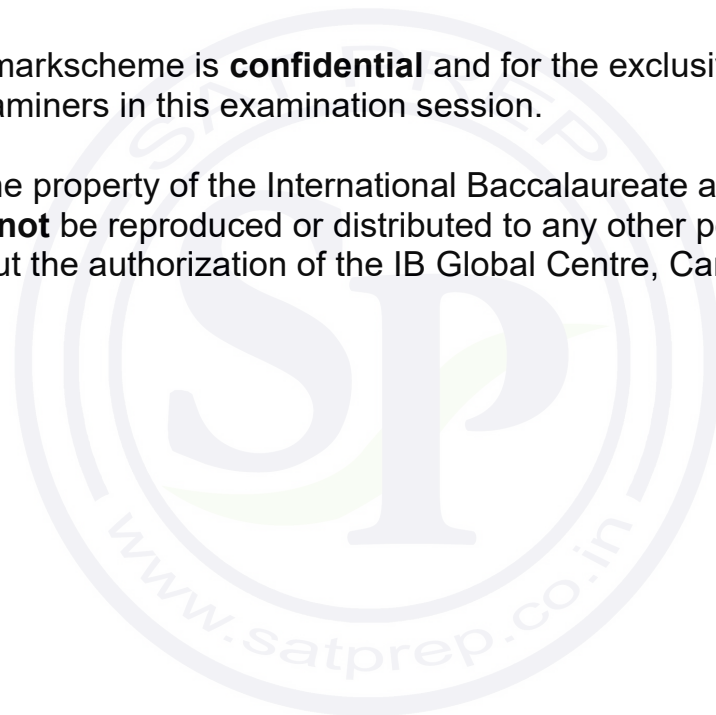

Instructions to Examiners

Abbreviations

- M** Marks awarded for attempting to use a correct **Method**.
- A** Marks awarded for an **Answer** or for **Accuracy**; often dependent on preceding **M** marks.
- R** Marks awarded for clear **Reasoning**.
- AG** Answer given in the question and so no marks are awarded.
- FT** Follow through. The practice of awarding marks, despite candidate errors in previous parts, for their correct methods/answers using incorrect results.

Using the markscheme

1 General

Award marks using the annotations as noted in the markscheme eg **M1**, **A2**.

2 Method and Answer/Accuracy marks

- Do **not** automatically award full marks for a correct answer; all working **must** be checked, and marks awarded according to the markscheme.
- It is generally not possible to award **M0** followed by **A1**, as **A** mark(s) depend on the preceding **M** mark(s), if any.
- Where **M** and **A** marks are noted on the same line, e.g. **M1A1**, this usually means **M1** for an **attempt** to use an appropriate method (e.g. substitution into a formula) and **A1** for using the **correct** values.
- Where there are two or more **A** marks on the same line, they may be awarded independently; so if the first value is incorrect, but the next two are correct, award **A0A1A1**.
- Where the markscheme specifies **A3**, **M2** etc., do **not** split the marks, unless there is a note.
- The response to a “show that” question does not need to restate the **AG** line, unless a **Note** makes this explicit in the markscheme.
- Once a correct answer to a question or part question is seen, ignore further working even if this working is incorrect and/or suggests a misunderstanding of the question. This will encourage a uniform approach to marking, with less examiner discretion. Although some candidates may be advantaged for that specific question item, it is likely that these candidates will lose marks elsewhere too.
- An exception to the previous rule is when an incorrect answer from further working is used **in a subsequent part**. For example, when a correct exact value is followed by an incorrect decimal approximation in the first part and this approximation is then used in the second part. In this situation, award **FT** marks as appropriate but do not award the final **A1** in the first part. Examples:

	Correct answer seen	Further working seen	Any FT issues?	Action
1.	$8\sqrt{2}$	5.65685... (incorrect decimal value)	No. Last part in question.	Award A1 for the final mark (condone the incorrect further working)
2.	$\frac{35}{72}$	0.468111... (incorrect decimal value)	Yes. Value is used in subsequent parts.	Award A0 for the final mark (and full FT is available in subsequent parts)

3 Implied marks

Implied marks appear in **brackets e.g. (M1)**, and can only be awarded if **correct** work is seen or implied by subsequent working/answer.

4 Follow through marks (only applied after an error is made)

Follow through (**FT**) marks are awarded where an incorrect answer from one **part** of a question is used correctly in **subsequent** part(s) (e.g. incorrect value from part (a) used in part (d) or incorrect value from part (c)(i) used in part (c)(ii)). Usually, to award **FT** marks, **there must be working present** and not just a final answer based on an incorrect answer to a previous part. However, if all the marks awarded in a subsequent part are for the answer or are implied, then **FT** marks should be awarded for *their* correct answer, even when working is not present.

For example: following an incorrect answer to part (a) that is used in subsequent parts, where the markscheme for the subsequent part is **(M1)A1**, it is possible to award full marks for *their* correct answer, **without working being seen**. For longer questions where all but the answer marks are implied this rule applies but may be overwritten by a **Note** in the Markscheme.

- Within a question part, once an **error** is made, no further **A** marks can be awarded for work which uses the error, but **M** marks may be awarded if appropriate.
- If the question becomes much simpler because of an error then use discretion to award fewer **FT** marks, by reflecting on what each mark is for and how that maps to the simplified version.
- If the error leads to an inappropriate value (e.g. probability greater than 1, $\sin \theta = 1.5$, non-integer value where integer required), do not award the mark(s) for the final answer(s).
- The markscheme may use the word “their” in a description, to indicate that candidates may be using an incorrect value.
- If the candidate’s answer to the initial question clearly contradicts information given in the question, it is not appropriate to award any **FT** marks in the subsequent parts. This includes when candidates fail to complete a “show that” question correctly, and then in subsequent parts use their incorrect answer rather than the given value.
- Exceptions to these **FT** rules will be explicitly noted on the markscheme.
- If a candidate makes an error in one part but gets the correct answer(s) to subsequent part(s), award marks as appropriate, unless the command term was “Hence”.

5 Mis-read

If a candidate incorrectly copies values or information from the question, this is a mis-read (**MR**). A candidate should be penalized only once for a particular misread. Use the **MR** stamp to indicate that this has been a misread and do not award the first mark, even if this is an **M** mark, but award all others as appropriate.

- If the question becomes much simpler because of the **MR**, then use discretion to award fewer marks.
- If the **MR** leads to an inappropriate value (e.g. probability greater than 1, $\sin \theta = 1.5$, non-integer value where integer required), do not award the mark(s) for the final answer(s).
- Miscopying of candidates' own work does **not** constitute a misread, it is an error.
- If a candidate uses a correct answer, to a "show that" question, to a higher degree of accuracy than given in the question, this is NOT a misread and full marks may be scored in the subsequent part.
- **MR** can only be applied when work is seen. For calculator questions with no working and incorrect answers, examiners should **not** infer that values were read incorrectly.

6 Alternative methods

Candidates will sometimes use methods other than those in the markscheme. Unless the question specifies a method, other correct methods should be marked in line with the markscheme. If the command term is 'Hence' and not 'Hence or otherwise' then alternative methods are not permitted unless covered by a note in the mark scheme.

- Alternative methods for complete questions are indicated by **METHOD 1**, **METHOD 2**, etc.
- Alternative solutions for parts of questions are indicated by **EITHER . . . OR**.

7 Alternative forms

Unless the question specifies otherwise, **accept** equivalent forms.

- As this is an international examination, accept all alternative forms of **notation** for example 1.9 and 1,9 or 1000 and 1,000 and 1.000.
- Do not accept final answers written using calculator notation. However, **M** marks and intermediate **A** marks can be scored, when presented using calculator notation, provided the evidence clearly reflects the demand of the mark.
- In the markscheme, equivalent **numerical** and **algebraic** forms will generally be written in brackets immediately following the answer.
- In the markscheme, some **equivalent** answers will generally appear in brackets. Not all equivalent notations/answers/methods will be presented in the markscheme and examiners are asked to apply appropriate discretion to judge if the candidate work is equivalent.

8 Format and accuracy of answers

If the level of accuracy is specified in the question, a mark will be linked to giving the answer to the required accuracy. If the level of accuracy is not stated in the question, the general rule applies to final answers: *unless otherwise stated in the question all numerical answers must be given exactly or correct to three significant figures.*

Where values are used in subsequent parts, the markscheme will generally use the exact value, however candidates may also use the correct answer in subsequent parts. The markscheme will often explicitly include the subsequent values that come “*from the use of 3 sf values*”.

Simplification of final answers: Candidates are advised to give final answers using good mathematical form. In general, for an **A** mark to be awarded, arithmetic should be completed, and

any values that lead to integers should be simplified; for example, $\sqrt{\frac{25}{4}}$ should be written as $\frac{5}{2}$.

An exception to this is simplifying fractions, where lowest form is not required (although the numerator and the denominator must be integers); for example, $\frac{10}{4}$ may be left in this form or

written as $\frac{5}{2}$. However, $\frac{10}{5}$ should be written as 2, as it simplifies to an integer.

Algebraic expressions should be simplified by completing any operations such as addition and multiplication, e.g. $4e^{2x} \times e^{3x}$ should be simplified to $4e^{5x}$, and $4e^{2x} \times e^{3x} - e^{4x} \times e^x$ should be simplified to $3e^{5x}$. Unless specified in the question, expressions do not need to be factorized, nor do factorized expressions need to be expanded, so $x(x+1)$ and x^2+x are both acceptable.

Please note: intermediate **A** marks do NOT need to be simplified.

9 Calculators

A GDC is required for this paper, but If you see work that suggests a candidate has used any calculator not approved for IB DP examinations (eg CAS enabled devices), please follow the procedures for malpractice.

10. Presentation of candidate work

Crossed out work: If a candidate has drawn a line through work on their examination script, or in some other way crossed out their work, do not award any marks for that work unless an explicit note from the candidate indicates that they would like the work to be marked.

More than one solution: Where a candidate offers two or more different answers to the same question, an examiner should only mark the first response unless the candidate indicates otherwise. If the layout of the responses makes it difficult to judge, examiners should apply appropriate discretion to judge which is “first”.



1. (a) 1.2 metres **A1**
[1 mark]

(b) $-4.8t^2 + 21t + 1.2 = 0$ **(M1)**
 $(t =) 4.43 \text{ s } (4.431415... \text{ s})$ **A1**

Note: If both values for t are seen do not award the **A1** mark unless the negative is explicitly excluded.

[2 marks]

(c) $0 \leq t \leq 4.43$ **OR** $[0, 4.43]$ **A1A1**

Note: Award **A1** for correct endpoints and **A1** for expressing answer with correct notation. Award at most **A1A0** for use of x instead of t .

[2 marks]

[Total 5 marks]

2. (a) $x + y + z = 600$ **A1**
 $15x + 10y + 12z = 7816$ **A1**
 $x = 2y$ **A1**

Note: Condone other labelling if clear, e.g. a (adult), c (child) and s (student).
 Accept equivalent, distinct equations e.g. $2y + y + z = 600$.

[3 marks]

(b) $x = 308, y = 154, z = 138$ **A1A1**

Note: Award **A1** for all three correct values seen, **A1** for correctly labelled as x, y or z .
 Accept answers written in words: e.g. 308 adult tickets.

[2 marks]

[Total 5 marks]

3. (a) H_0 : The die is fair **OR** $P(\text{any number}) = \frac{1}{6}$ **OR** probabilities are equal

H_1 : The die is not fair **OR** $P(\text{any number}) \neq \frac{1}{6}$ **OR** probabilities are not equal **A1**

[1 mark]

(b) 5

A1

[1 mark]

(c) 10

A1

[1 mark]

(d) (p -value =) 0.287 (0.28724163....)

A2

[2 marks]

(e) $0.287 > 0.05$

R1

EITHER

Insufficient evidence to reject the null hypothesis

A1

OR

Insufficient evidence to reject that the die is fair

A1

Note: Do not award **R0A1**. Condone “accept the null hypothesis” or “the die is fair”.
Their conclusion must be consistent with their p -value and their hypothesis.

[2 marks]

[Total 7 marks]

4. (a)

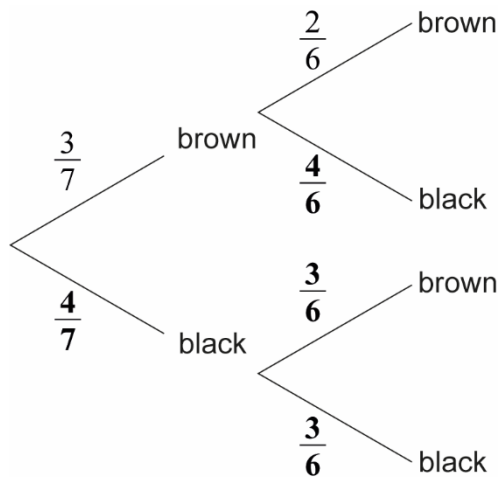

A1A1

Note: Award **A1** for $\frac{4}{7}$ and $\frac{4}{6}$ correctly placed, **A1** for final two probabilities correct.

[2 marks]

(b) multiplying along branches and then adding outcomes

(M1)

$$\frac{3}{7} \times \frac{2}{6} + \frac{4}{7} \times \frac{3}{6}$$

$$= \frac{18}{42} \left(= \frac{3}{7} \approx 0.429 \text{ (42.9\%)} \right)$$

A1

[2 marks]

(c) use of conditional probability formula

M1

$$\frac{\left(\frac{3}{7} \times \frac{2}{6} \right)}{\left(\frac{3}{7} \right)}$$

$$= \frac{6}{18} \left(= \frac{1}{3} \right) \left(\frac{252}{756}, 0.333, 33.3\% \right)$$

A1

A1

[3 marks]

[Total 7 marks]

5. (a) use of geometric sequence with $r = 0.85$ **M1**

EITHER

$(0.85)^6(1.8)$ **OR** $0.678869\dots$ **OR** $(0.85)^5(1.53)$ **A1**

$= 0.68 \text{ m}$

$= 68 \text{ cm}$ **AG**

OR

$(0.85)^6(180)$ **OR** $(0.85)^5(153)$ **A1**

$= 68 \text{ cm}$ **AG**

[2 marks]

(b) **EITHER**

$(0.85)^n(1.8) > 0.1$ **OR** $(0.85)^{n-1}(1.53) > 0.1$ **(M1)**

Note: If 1.8 m (or 180 cm) is used then **(M1)** only awarded for use of n in $(0.85)^n(1.8) > 0.1$.
If 1.53 m (or 153 cm) is used then **(M1)** only awarded for use of $n-1$ in $(0.85)^{n-1}(1.53) > 0.1$.

17 **A1**

OR

$(0.85)^{17}(1.8) = 0.114 \text{ m}$ and $(0.85)^{18}(1.8) = 0.0966 \text{ m}$ **(M1)**

17 **A1**

OR

solving $(0.85)^n(1.8) = 0.1$ to find $n = 17.8$ **(M1)**

17 **A1**

Note: Evidence of solving may be a graph **OR** the “solver” function **OR** use of logs to solve the equation. Working may use cm.

[2 marks]

continued...

Question 5 continued

(c) **EITHER**

distance (in one direction) travelled between first and fourth bounce

$$= \frac{(1.8 \times 0.85)(1 - 0.85^3)}{1 - 0.85} (= 3.935925) \quad \text{(A1)}$$

recognizing distances are travelled twice except first distance (M1)

$$1.8 + 2(3.935925)$$

$$= 9.67 \text{ m (9.67185... m)} \quad \text{A1}$$

OR

distance (in one direction) travelled between drop and fourth bounce

$$= \frac{(1.8)(1 - 0.85^4)}{1 - 0.85} (= 5.735925) \quad \text{(A1)}$$

recognizing distances are travelled twice except first distance (M1)

$$2(5.735925) - 1.8$$

$$= 9.67 \text{ m (9.67185... m)} \quad \text{A1}$$

OR

distance (in one direction) travelled between first and fourth bounce

$$(0.85)(1.8) + (0.85)^2(1.8) + (0.85)^3(1.8) (= 3.935925...) \quad \text{(A1)}$$

recognizing distances are travelled twice except first distance (M1)

$$1.8 + 2(0.85)(1.8) + 2(0.85)^2(1.8) + 2(0.85)^3(1.8)$$

$$= 9.67 \text{ m (9.67185... m)} \quad \text{A1}$$

Note: Answers may be given in cm.

[3 marks]
[Total 7 marks]

6. (a) $\begin{pmatrix} -3.2 \\ -4.5 \\ 6.1 \end{pmatrix}$ A1

[1 mark]

(b) $\sqrt{(-3.2)^2 + (-4.5)^2 + 6.1^2}$ (M1)
 $8.22800... \approx 8.23 \text{ m}$ A1

[2 marks]

(c) EITHER

$\vec{AO} = \begin{pmatrix} -3.2 \\ -4.5 \\ 0.3 \end{pmatrix}$ A1

$\cos \theta = \frac{\vec{AO} \cdot \vec{AF}}{|\vec{AO}| |\vec{AF}|}$

$\vec{AO} \cdot \vec{AF} = (-3.2)^2 + (-4.5)^2 + (0.3 \times 6.1) (= 32.32)$ (A1)

$\cos \theta = \frac{32.32}{\sqrt{3.2^2 + 4.5^2 + 0.3^2} \times 8.22800...}$ (M1)

$= 0.710326...$ (A1)

Note: If \vec{OA} is used in place of \vec{AO} then $\cos \theta$ will be negative.
 Award **A1(A1)(M1)(A1)** as above. In order to award the final **A1**, some justification for changing the resulting obtuse angle to its supplementary angle **must** be seen.

OR
 $AO = \sqrt{3.2^2 + 4.5^2 + 0.3^2} (= 5.52991...)$ (A1)

$\cos \theta = \frac{8.22800...^2 + 5.52991...^2 - 5.8^2}{2 \times 8.22800... \times 5.52991...}$ (M1)(A1)

$= 0.710326...$ (A1)

THEN

$\theta = 0.780833... \approx 0.781$ **OR** $44.7384...^\circ \approx 44.7^\circ$ A1

[5 marks]
 [Total 8 marks]

7. (a) (i) $x^2 + \frac{y}{2} = 0$ ($y = -2x^2$) **A1**

(ii) $y = -2x^2$ drawn on diagram (correct shape with a maximum at $(0, 0)$) **A1**

[2 marks]

(b)

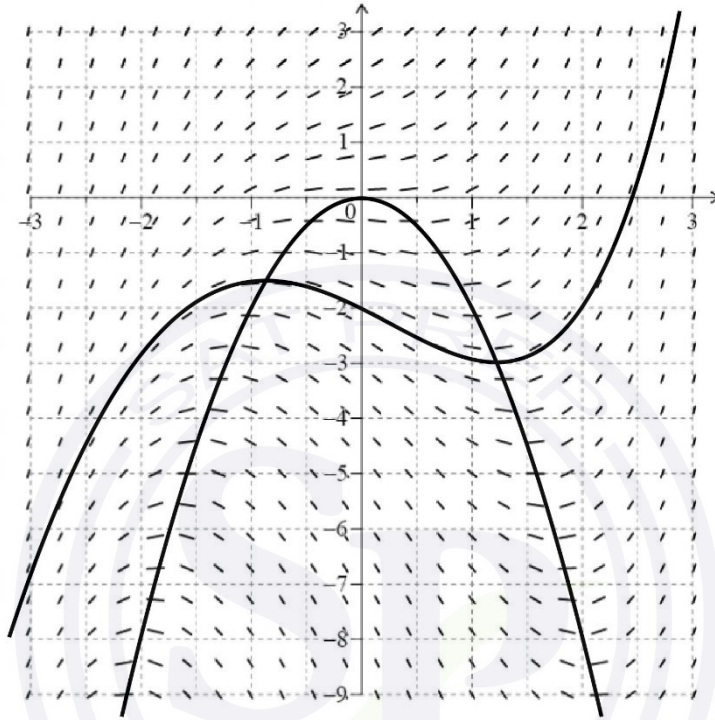

correct shape with a local maximum and minimum, passing through $(0, -2)$ **A1**

local maximum and minimum on the graph of $y = -2x^2$ **A1**

[2 marks]

[Total 4 marks]

8. (a) (i) use of product rule (M1)

$$\frac{dy}{dx} = 2(4 - e^x) + 2x(-e^x)$$

A1

$$= 8 - 2e^x - 2xe^x$$

(ii) use of product rule (M1)

$$\frac{d^2y}{dx^2} = -2e^x - 2e^x - 2xe^x$$

A1

$$= -4e^x - 2xe^x$$

$$= -2(2 + x)e^x$$

[4 marks]

(b) $-2(2 + a)e^a = 0$ OR sketch of $\frac{d^2y}{dx^2}$ with x -intercept indicated

OR finding the local maximum of $\frac{dy}{dx}$ at $(-2, 8.27)$ (M1)

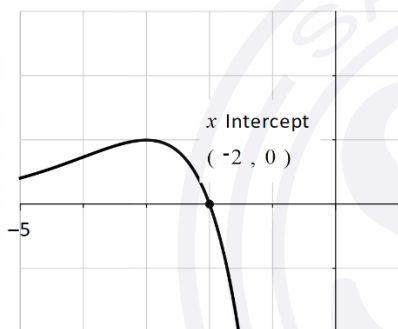

$(a =) -2$

A1

[2 marks]
[Total 6 marks]

9. (a) let X be the weight of sugar in the bag

$$P(X < 950) = 0.308537... \approx 0.309$$

(M1)A1

[2 marks]

- (b) **METHOD 1**

let \bar{X} be the mean weight of 5 bags of sugar

$$E(\bar{X}) = 1000$$

(A1)

$$\text{use of } \text{Var}(\bar{X}) = \frac{\sigma^2}{n}$$

(M1)

$$\text{Var}(\bar{X}) = \frac{100^2}{5} (= 2000)$$

(A1)

$$\bar{X} \sim N(1000, 2000)$$

$$P(\bar{X} > 950) = 0.868223... \approx 0.868 \text{ (86.8\%)}$$

A1

METHOD 2

let T be the total weight of 5 bags of sugar

$$E(T) = 5000$$

(A1)

use of $\text{Var}(X_1 + X_2) = \text{Var}(X_1) + \text{Var}(X_2)$ for independent random variables

(M1)

$$\text{Var}(T) = 5 \times 100^2 (= 50000)$$

(A1)

$$T \sim N(5000, 50000)$$

$$P(T > 4750) = 0.868223... \approx 0.868 \text{ (86.8\%)}$$

A1

[4 marks]

[Total 6 marks]

10. (a)

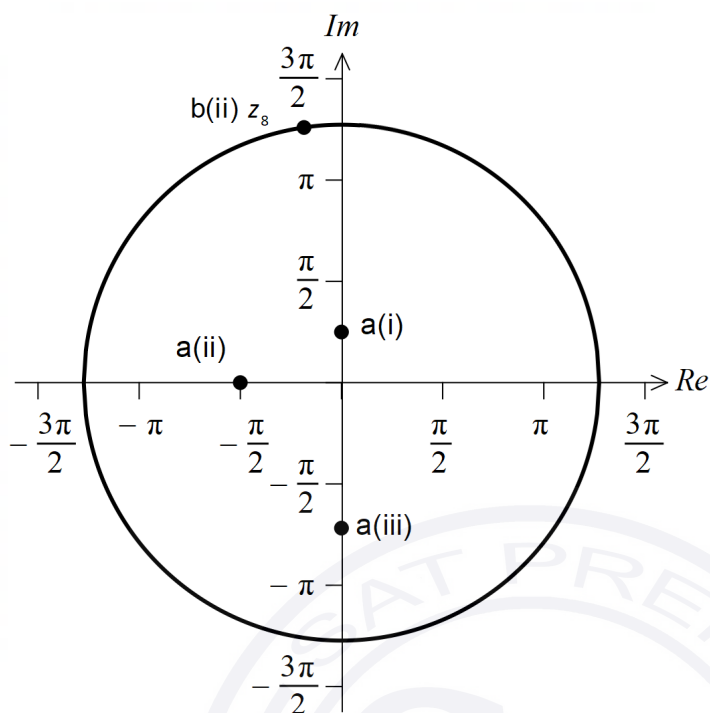

A1A1A1

Note: Award **A1** for correct modulus and **A1** for correct argument for part (a)(i), and **A1** for other two points correct. The points may not be labelled, and they may be shown by line segments.

[3 marks]

(b) (i) $\frac{1}{2}\theta = 4$ **(M1)**
 $\Rightarrow \theta = 8$ **A1**

(ii) z_8 is shown in the diagram above **A1A1**

Note: Award **A1** for a point plotted on the circle and **A1** for a point plotted in the second quadrant.

[4 marks]
 [Total 7 marks]

11. (a) $\lambda = 1$

$$\begin{pmatrix} -0.8 & 0.7 \\ 0.8 & -0.7 \end{pmatrix} \begin{pmatrix} x \\ y \end{pmatrix} = \begin{pmatrix} 0 \\ 0 \end{pmatrix} \quad \text{OR} \quad \begin{pmatrix} 0.2 & 0.7 \\ 0.8 & 0.3 \end{pmatrix} \begin{pmatrix} x \\ y \end{pmatrix} = \begin{pmatrix} x \\ y \end{pmatrix} \quad (M1)$$

$$0.8x = 0.7y \quad (A1)$$

an eigenvector is $\begin{pmatrix} 7 \\ 8 \end{pmatrix}$ (or equivalent with integer values) A1

[3 marks]

(b) **EITHER**

(the long-term probability matrix is given by the eigenvector corresponding to the eigenvalue equal to 1, scaled so that the sum of the entries is 1)

$$8 + 7 = 15 \quad (M1)$$

OR

$$\begin{pmatrix} 0.2 & 0.7 \\ 0.8 & 0.3 \end{pmatrix} \begin{pmatrix} p \\ 1-p \end{pmatrix} = \begin{pmatrix} p \\ 1-p \end{pmatrix} \quad (M1)$$

OR

considering high powers of the matrix e.g. $\begin{pmatrix} 0.2 & 0.7 \\ 0.8 & 0.3 \end{pmatrix}^{50}$ (M1)

$$\begin{pmatrix} \frac{7}{15} & \frac{7}{15} \\ \frac{8}{15} & \frac{8}{15} \end{pmatrix}$$

THEN

probability of being in state A is $\frac{7}{15}$ A1

[2 marks]

[Total 5 marks]

12. (a) $\log_{10} 100 = a - 3$ (M1)
 $a = 5$ A1
 [2 marks]
- (b) **EITHER**
 $N = 10^{5-M}$ (M1)
 $= \frac{10^5}{10^M} \left(= \frac{100000}{10^M} \right)$
- OR**
 $100 = \frac{b}{10^3}$ (M1)
- THEN**
 $b = 100000 (=10^5)$ A1
 [2 marks]
- (c) $N = \frac{10^5}{10^{7.2}} = 0.00631$ (0.0063095...) A1
- Note:** Do not accept an answer of $10^{-2.2}$.
- [1 mark]
- (d) **METHOD 1**
 $Y > 100 \Rightarrow$ no earthquakes in the first 100 years (M1)
- EITHER**
 let X be the number of earthquakes of at least magnitude 7.2 in a year
 $X \sim \text{Po}(0.0063095\dots)$
 $(P(X = 0))^{100}$ (M1)
- OR**
 let X be the number of earthquakes in 100 years
 $X \sim \text{Po}(0.0063095\dots \times 100)$ (M1)
 $P(X = 0)$
- THEN**
 0.532 (0.532082...) A1
- METHOD 2**
 $Y > 100 \Rightarrow$ no earthquakes in the first 100 years (M1)
 let X be the number of earthquakes in 100 years
 since n is large and p is small
 $X \sim \text{B}(100, 0.0063095\dots)$ (M1)
 $P(X = 0)$
 0.531 (0.531019...) A1
 [3 marks]
 [Total 8 marks]

13. (a) $(r =) \begin{pmatrix} 1 \\ 4 \end{pmatrix} + t \begin{pmatrix} 1.2 \\ -0.6 \end{pmatrix}$ **A1**

Note: Do not condone the use of λ or any other variable apart from t .

[1 mark]

(b) when the bearing from the port is 045° , the distance east from the port is equal to the distance north from the port **(M1)**

$1 + 1.2t = 4 - 0.6t$ **(A1)**

$1.8t = 3$

$t = \frac{5}{3}$ (1.6666..., 1 hour 40 minutes) **(A1)**

time is 2:40 pm (14:40) **A1**

[4 marks]

[Total 5 marks]

14. (a) (i) $\frac{1}{u^2} + \frac{2}{u} + 1$ **A1**

(ii) $\int \left(\frac{1}{(x+2)} + 1 \right)^2 dx$ **(M1)**
 $= \int \left(\frac{1}{(x+2)^2} + \frac{2}{x+2} + 1 \right) dx$ **OR** $\int \left(\frac{1}{u^2} + \frac{2}{u} + 1 \right) du$

$= -\frac{1}{(x+2)} + 2 \ln|x+2| + x(+c)$ **A1A1**

Note: Award **A1** for first expression, **A1** for second two expressions.

Award **A1A0** for a final answer of $= -\frac{1}{u} + 2 \ln(u) + u(+c)$.

[4 marks]

continued...

Question 14 continued

(b) volume = $\pi \left[-\frac{1}{(x+2)} + 2 \ln(x+2) + x \right]_0^2$ **M1**

= $\pi \left(-\frac{1}{4} + 2 \ln(4) + 2 + \frac{1}{2} - 2 \ln 2 \right)$ **A1**

= $\pi \left(\frac{9}{4} + 2 \ln(4) - 2 \ln 2 \right)$

use of log laws seen, for example **M1**

$\pi \left(\frac{9}{4} + 4 \ln(2) - 2 \ln 2 \right)$ **OR** $\pi \left(\frac{9}{4} + 2 \ln \left(\frac{4}{2} \right) \right)$

= $\frac{\pi}{4} (9 + 8 \ln(2))$ **OR** $a = 9, b = 8$ and $c = 2$ **A1**

Note: Other correct integer solutions are possible and should be accepted for example $a = 9, b = c = 4$.

[4 marks]
Total [8 marks]

15. (a) $X \sim \text{Po}(324)$ **A1**

Note: Both distribution and mean must be seen for **A1** to be awarded.

[1 mark]

(b) $P(X \leq 300)$ **(M1)**
= 0.0946831... \approx 0.0947 **A1**

[2 marks]

(c) (mean number of cars =) $4.5 \times 60 = 270$ **(A1)**
 $P(X > 300 | \lambda = 270)$ **(M1)**

Note: Award **M1** for using $\lambda = 270$ to evaluate a probability.

$P(X \geq 301)$ **OR** $1 - P(X \leq 300)$ **(M1)**
= 0.0334207... \approx 0.0334 **A1**

[4 marks]
[Total 7 marks]

16. (a) use of power rule (M1)

$$\frac{dW}{dv} = -1.1848v^{-0.84} \quad \text{OR} \quad -1.18v^{-0.84} \quad \text{A1}$$

[2 marks]

(b) $\frac{dv}{dt} = 5$ (A1)

$$\frac{dW}{dt} = \frac{dv}{dt} \times \frac{dW}{dv} \quad \text{(M1)}$$

$$\left(\frac{dW}{dt} = -5 \times 1.1848v^{-0.84} \right)$$

when $v = 10$

$$\frac{dW}{dt} = -5 \times 1.1848 \times 10^{-0.84} \quad \text{(M1)}$$

$$-0.856 \quad (-0.856278\dots)^\circ\text{C min}^{-1} \quad \text{A2}$$

Note: Accept a negative answer communicated in words, “decreasing at a rate of...”.
 Accept a final answer of $-0.852809\dots^\circ\text{C min}^{-1}$ from use of -1.18 .
 Accept 51.4 (or 51.2) $^\circ\text{C hour}^{-1}$.

[5 marks]
 [Total 7 marks]

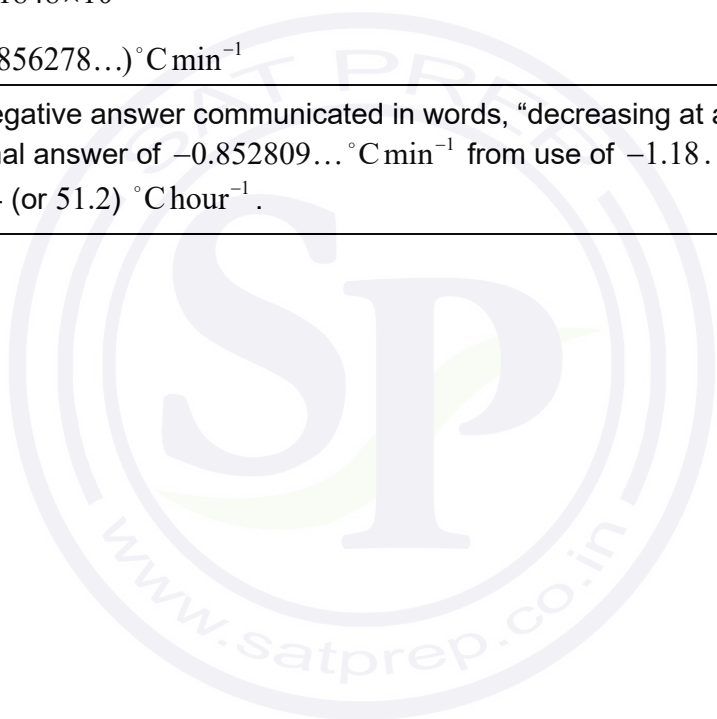

17. substitute coordinates of A

$$f(0) = p e^{q \cos(0)} = 6.5$$

$$6.5 = p e^q \quad \text{(A1)}$$

substitute coordinates of B

$$f(5.2) = p e^{q \cos(5.2r)} = 0.2$$

EITHER

$$f'(t) = -pqr \sin(rt) e^{q \cos(rt)} \quad \text{(M1)}$$

minimum occurs when $-pqr \sin(5.2r) e^{q \cos(5.2r)} = 0$

$$\sin(rt) = 0$$

$$r \times 5.2 = \pi \quad \text{(A1)}$$

OR

minimum value occurs when $\cos(rt) = -1$ (M1)

$$r \times 5.2 = \pi \quad \text{(A1)}$$

OR

period = $2 \times 5.2 = 10.4$ (A1)

$$r = \frac{2\pi}{10.4} \quad \text{(M1)}$$

THEN

$$r = \frac{\pi}{5.2} = 0.604152... \text{ (0.604)} \quad \text{A1}$$

$$0.2 = p e^{-q} \quad \text{(A1)}$$

eliminate p or q (M1)

$$e^{2q} = \frac{6.5}{0.2} \quad \text{OR} \quad 0.2 = \frac{p^2}{6.5}$$

$$q = 1.74 \text{ (1.74062...)} \quad \text{A1}$$

$$p = 1.14017... \text{ (1.14)} \quad \text{A1}$$

[Total 8 marks]

Markscheme

November 2021

**Mathematics:
applications and interpretation**

Higher level

Paper 1

© International Baccalaureate Organization 2021

All rights reserved. No part of this product may be reproduced in any form or by any electronic or mechanical means, including information storage and retrieval systems, without the prior written permission from the IB. Additionally, the license tied with this product prohibits use of any selected files or extracts from this product. Use by third parties, including but not limited to publishers, private teachers, tutoring or study services, preparatory schools, vendors operating curriculum mapping services or teacher resource digital platforms and app developers, whether fee-covered or not, is prohibited and is a criminal offense.

More information on how to request written permission in the form of a license can be obtained from <https://ibo.org/become-an-ib-school/ib-publishing/licensing/applying-for-a-license/>.

© Organisation du Baccalauréat International 2021

Tous droits réservés. Aucune partie de ce produit ne peut être reproduite sous quelque forme ni par quelque moyen que ce soit, électronique ou mécanique, y compris des systèmes de stockage et de récupération d'informations, sans l'autorisation écrite préalable de l'IB. De plus, la licence associée à ce produit interdit toute utilisation de tout fichier ou extrait sélectionné dans ce produit. L'utilisation par des tiers, y compris, sans toutefois s'y limiter, des éditeurs, des professeurs particuliers, des services de tutorat ou d'aide aux études, des établissements de préparation à l'enseignement supérieur, des fournisseurs de services de planification des programmes d'études, des gestionnaires de plateformes pédagogiques en ligne, et des développeurs d'applications, moyennant paiement ou non, est interdite et constitue une infraction pénale.

Pour plus d'informations sur la procédure à suivre pour obtenir une autorisation écrite sous la forme d'une licence, rendez-vous à l'adresse <https://ibo.org/become-an-ib-school/ib-publishing/licensing/applying-for-a-license/>.

© Organización del Bachillerato Internacional, 2021

Todos los derechos reservados. No se podrá reproducir ninguna parte de este producto de ninguna forma ni por ningún medio electrónico o mecánico, incluidos los sistemas de almacenamiento y recuperación de información, sin la previa autorización por escrito del IB. Además, la licencia vinculada a este producto prohíbe el uso de todo archivo o fragmento seleccionado de este producto. El uso por parte de terceros —lo que incluye, a título enunciativo, editoriales, profesores particulares, servicios de apoyo académico o ayuda para el estudio, colegios preparatorios, desarrolladores de aplicaciones y entidades que presten servicios de planificación curricular u ofrezcan recursos para docentes mediante plataformas digitales—, ya sea incluido en tasas o no, está prohibido y constituye un delito.

En este enlace encontrará más información sobre cómo solicitar una autorización por escrito en forma de licencia: <https://ibo.org/become-an-ib-school/ib-publishing/licensing/applying-for-a-license/>.

Instructions to Examiners

Abbreviations

- M** Marks awarded for attempting to use a correct **Method**.
- A** Marks awarded for an **Answer** or for **Accuracy**; often dependent on preceding **M** marks.
- R** Marks awarded for clear **Reasoning**.
- AG** Answer given in the question and so no marks are awarded.
- FT** Follow through. The practice of awarding marks, despite candidate errors in previous parts, for their correct methods/answers using incorrect results.

Using the markscheme

1 General

Award marks using the annotations as noted in the markscheme eg **M1**, **A2**.

2 Method and Answer/Accuracy marks

- Do **not** automatically award full marks for a correct answer; all working **must** be checked, and marks awarded according to the markscheme.
- It is generally not possible to award **M0** followed by **A1**, as **A** mark(s) depend on the preceding **M** mark(s), if any.
- Where **M** and **A** marks are noted on the same line, e.g. **M1A1**, this usually means **M1** for an **attempt** to use an appropriate method (e.g. substitution into a formula) and **A1** for using the **correct** values.
- Where there are two or more **A** marks on the same line, they may be awarded independently; so if the first value is incorrect, but the next two are correct, award **A0A1A1**.
- Where the markscheme specifies **A3**, **M2** etc., do **not** split the marks, unless there is a note.
- The response to a “show that” question does not need to restate the **AG** line, unless a **Note** makes this explicit in the markscheme.
- Once a correct answer to a question or part question is seen, ignore further working even if this working is incorrect and/or suggests a misunderstanding of the question. This will encourage a uniform approach to marking, with less examiner discretion. Although some candidates may be advantaged for that specific question item, it is likely that these candidates will lose marks elsewhere too.
- An exception to the previous rule is when an incorrect answer from further working is used **in a subsequent part**. For example, when a correct exact value is followed by an incorrect decimal approximation in the first part and this approximation is then used in the second part. In this situation, award **FT** marks as appropriate but do not award the final **A1** in the first part. Examples:

	Correct answer seen	Further working seen	Any FT issues?	Action
1.	$8\sqrt{2}$	5.65685... (incorrect decimal value)	No. Last part in question.	Award A1 for the final mark (condone the incorrect further working)
2.	$\frac{35}{72}$	0.468111... (incorrect decimal value)	Yes. Value is used in subsequent parts.	Award A0 for the final mark (and full FT is available in subsequent parts)

3 Implied marks

Implied marks appear in **brackets e.g. (M1)**, and can only be awarded if **correct** work is seen or implied by subsequent working/answer.

4 Follow through marks (only applied after an error is made)

Follow through (**FT**) marks are awarded where an incorrect answer from one **part** of a question is used correctly in **subsequent** part(s) (e.g. incorrect value from part (a) used in part (d) or incorrect value from part (c)(i) used in part (c)(ii)). Usually, to award **FT** marks, **there must be working present** and not just a final answer based on an incorrect answer to a previous part. However, if all the marks awarded in a subsequent part are for the answer or are implied, then **FT** marks should be awarded for *their* correct answer, even when working is not present.

For example: following an incorrect answer to part (a) that is used in subsequent parts, where the markscheme for the subsequent part is **(M1)A1**, it is possible to award full marks for *their* correct answer, **without working being seen**. For longer questions where all but the answer marks are implied this rule applies but may be overwritten by a **Note** in the Markscheme.

- Within a question part, once an **error** is made, no further **A** marks can be awarded for work which uses the error, but **M** marks may be awarded if appropriate.
- If the question becomes much simpler because of an error then use discretion to award fewer **FT** marks, by reflecting on what each mark is for and how that maps to the simplified version.
- If the error leads to an inappropriate value (e.g. probability greater than 1, $\sin \theta = 1.5$, non-integer value where integer required), do not award the mark(s) for the final answer(s).
- The markscheme may use the word “their” in a description, to indicate that candidates may be using an incorrect value.
- If the candidate’s answer to the initial question clearly contradicts information given in the question, it is not appropriate to award any **FT** marks in the subsequent parts. This includes when candidates fail to complete a “show that” question correctly, and then in subsequent parts use their incorrect answer rather than the given value.
- Exceptions to these **FT** rules will be explicitly noted on the markscheme.
- If a candidate makes an error in one part but gets the correct answer(s) to subsequent part(s), award marks as appropriate, unless the command term was “Hence”.

5 Mis-read

If a candidate incorrectly copies values or information from the question, this is a mis-read (**MR**). A candidate should be penalized only once for a particular misread. Use the **MR** stamp to indicate that this has been a misread and do not award the first mark, even if this is an **M** mark, but award all others as appropriate.

- If the question becomes much simpler because of the **MR**, then use discretion to award fewer marks.
- If the **MR** leads to an inappropriate value (e.g. probability greater than 1, $\sin \theta = 1.5$, non-integer value where integer required), do not award the mark(s) for the final answer(s).
- Miscopying of candidates' own work does **not** constitute a misread, it is an error.
- If a candidate uses a correct answer, to a "show that" question, to a higher degree of accuracy than given in the question, this is NOT a misread and full marks may be scored in the subsequent part.
- **MR** can only be applied when work is seen. For calculator questions with no working and incorrect answers, examiners should **not** infer that values were read incorrectly.

6 Alternative methods

Candidates will sometimes use methods other than those in the markscheme. Unless the question specifies a method, other correct methods should be marked in line with the markscheme. If the command term is 'Hence' and not 'Hence or otherwise' then alternative methods are not permitted unless covered by a note in the mark scheme.

- Alternative methods for complete questions are indicated by **METHOD 1**, **METHOD 2**, etc.
- Alternative solutions for parts of questions are indicated by **EITHER . . . OR**.

7 Alternative forms

Unless the question specifies otherwise, **accept** equivalent forms.

- As this is an international examination, accept all alternative forms of **notation** for example 1.9 and 1,9 or 1000 and 1,000 and 1.000.
- Do not accept final answers written using calculator notation. However, **M** marks and intermediate **A** marks can be scored, when presented using calculator notation, provided the evidence clearly reflects the demand of the mark.
- In the markscheme, equivalent **numerical** and **algebraic** forms will generally be written in brackets immediately following the answer.
- In the markscheme, some **equivalent** answers will generally appear in brackets. Not all equivalent notations/answers/methods will be presented in the markscheme and examiners are asked to apply appropriate discretion to judge if the candidate work is equivalent.

8 Format and accuracy of answers

If the level of accuracy is specified in the question, a mark will be linked to giving the answer to the required accuracy. If the level of accuracy is not stated in the question, the general rule applies to final answers: *unless otherwise stated in the question all numerical answers must be given exactly or correct to three significant figures.*

Where values are used in subsequent parts, the markscheme will generally use the exact value, however candidates may also use the correct answer to 3 sf in subsequent parts. The markscheme will often explicitly include the subsequent values that come “*from the use of 3 sf values*”.

Simplification of final answers: Candidates are advised to give final answers using good mathematical form. In general, for an **A** mark to be awarded, arithmetic should be completed, and

any values that lead to integers should be simplified; for example, $\sqrt{\frac{25}{4}}$ should be written as $\frac{5}{2}$.

An exception to this is simplifying fractions, where lowest form is not required (although the numerator and the denominator must be integers); for example, $\frac{10}{4}$ may be left in this form or

written as $\frac{5}{2}$. However, $\frac{10}{5}$ should be written as 2, as it simplifies to an integer.

Algebraic expressions should be simplified by completing any operations such as addition and multiplication, e.g. $4e^{2x} \times e^{3x}$ should be simplified to $4e^{5x}$, and $4e^{2x} \times e^{3x} - e^{4x} \times e^x$ should be simplified to $3e^{5x}$. Unless specified in the question, expressions do not need to be factorized, nor do factorized expressions need to be expanded, so $x(x+1)$ and x^2+x are both acceptable.

Please note: intermediate **A** marks do NOT need to be simplified.

9 Calculators

A GDC is required for this paper, but If you see work that suggests a candidate has used any calculator not approved for IB DP examinations (eg CAS enabled devices), please follow the procedures for malpractice.

10. Presentation of candidate work

Crossed out work: If a candidate has drawn a line through work on their examination script, or in some other way crossed out their work, do not award any marks for that work unless an explicit note from the candidate indicates that they would like the work to be marked.

More than one solution: Where a candidate offers two or more different answers to the same question, an examiner should only mark the first response unless the candidate indicates otherwise. If the layout of the responses makes it difficult to judge, examiners should apply appropriate discretion to judge which is “first”.

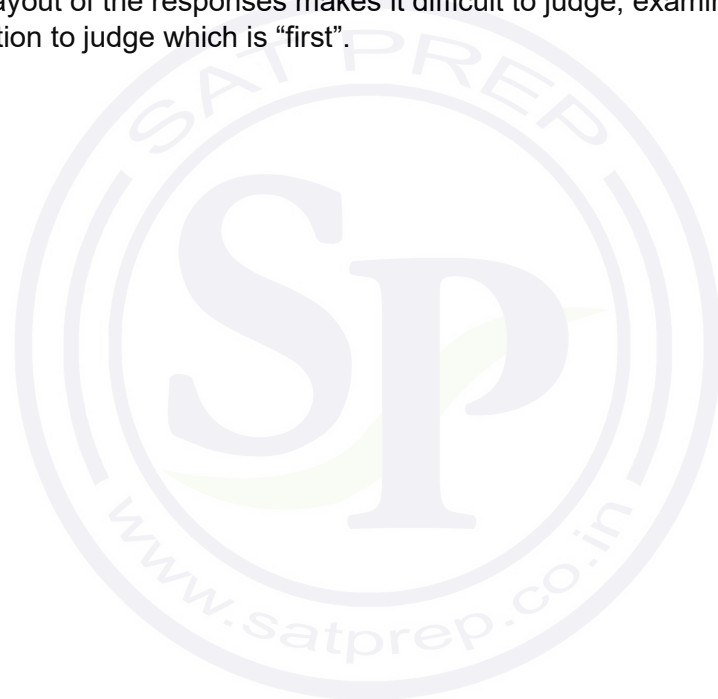

1. (a) $m = \frac{6-0}{4-2} = 3$ (M1)A1 [2 marks]
- (b) $(m =) -\frac{1}{3}$ (-0.333, -0.333333...) A1 [1 mark]
- (c) an equation of line with a correct intercept and either of their gradients from (a) or (b) (M1)
 e.g. $y = -\frac{1}{3}x + 4$ OR $y - 4 = -\frac{1}{3}(x - 0)$

Note: Award (M1) for substituting either of their gradients from parts (a) or (b) and point B or (3, 3) into equation of a line.

- $x + 3y - 12 = 0$ or any integer multiple A1 [2 marks]
- (d) $(x =) 12$ A1 [1 mark]
- Total: [6 marks]**

2. (a) attempt at using trapezoidal rule formula (M1)
- $\frac{1}{2} \left(\frac{2-0}{5} \right) (30 + 50 + 2(50 + 60 + 40 + 20))$ A1
- (total carbon =) 84 tonnes A1 [3 marks]
- (b) $\left| \frac{84-72}{72} \right| \times 100\%$ (M1)

Note: Award (M1) for correct substitution of final answer in part (a) into percentage error formula.

- = 16.7% (16.6666...%) A1 [2 marks]
- Total: [5 marks]**

3. (a) $h(4) = \frac{640}{4^2} + 0.5$ OR $h(14) = \frac{640}{14^2} + 0.5$ (M1)

Note: Award (M1) for substituting 4 or 14 into h . This can be implicit from seeing 3.77 (3.76530...) or 40.5.

$3.77 \leq h(x) \leq 40.5$ (3.76530... $\leq h(x) \leq 40.5$) A1A1

Note: Award A1 for both correct endpoints seen, A1 for the endpoints in a correct interval.

[3 marks]

(b) (i) $h(x) = 10$ OR $h^{-1}(x) = \sqrt{\frac{640}{x-0.5}}$ OR $h^{-1}(10) = \sqrt{\frac{640}{10-0.5}}$ (M1)
 (x =) 8.21 cm (8.20782...) A1

(ii) a tin that is 10 cm high will have a diameter of 8.21 cm (8.20782...) A1

Note: Condone a correct answer expressed as the converse.

(iii) $4 \leq h^{-1} \leq 14$ A1

Note: Accept $4 \leq y \leq 14$. Do not FT in this part.

[4 marks]

Total: [7 marks]

4. (a) (the best placement is either point P or point Q) attempt at using the distance formula (M1)

$AP = \sqrt{(10-6)^2 + (6-2)^2}$ OR

$BP = \sqrt{(10-14)^2 + (6-2)^2}$ OR

$DP = \sqrt{(10-10.8)^2 + (6-11.6)^2}$ OR

$BQ = \sqrt{(13-14)^2 + (7-2)^2}$ OR

$CQ = \sqrt{(13-18)^2 + (7-6)^2}$ OR

$DQ = \sqrt{(13-10.8)^2 + (7-11.6)^2}$

(AP or BP or DP =) $\sqrt{32} = 5.66$ (5.65685...) AND

(BQ or CQ or DQ =) $\sqrt{26} = 5.10$ (5.09901...) A1

$\sqrt{32} > \sqrt{26}$ OR AP (or BP or DP) is greater than BQ (or CQ or DQ) A1

point P is the furthest away AG

Note: Follow through from their values provided their AP (or BP or DP) is greater than their BQ (or CQ or DQ).

[3 marks]

continued...

Question 4 continued

(b) (i) $x = 14$

A1

(ii)

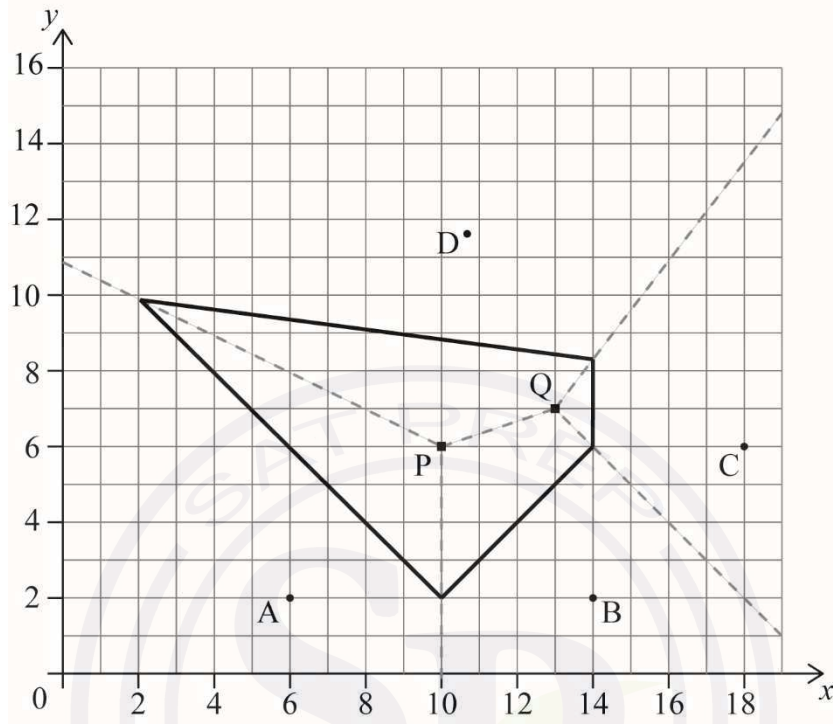

A1A1

Note: Award **A1** for each correct straight line. Do not **FT** from their part b(i).

[3 marks]
Total: [6 marks]

5. (a) $N = 360$
 $I\% = 3.8$
 $PV = (\pm)170\,000$
 $FV = 0$
 $P/Y = 12$
 $C/Y = 12$ **(M1)(A1)**

Note: Award **(M1)** for an attempt to use a financial app in their technology with at least two entries seen, award **A1** for all entries correct. Accept a positive or negative value for PV .

$(PMT =) 792.13 \text{ AUD}$ **A1**

Note: Accept an answer of -792.13 . Do not award final **A1** if answer is not given correct to 2 dp

[3 marks]

- (b) (i) $N = 120$
 $I\% = 3.8$
 $PV = (\pm)170\,000$
 $PMT = (\mp)792.13$
 $P/Y = 12$
 $C/Y = 12$ **(M1)(A1)**

Note: Award **(M1)** for an attempt to use a financial app in their technology with a least two entries seen, award **A1** for all entries correct. PV and PMT must have opposite signs.

$(FV =) 133019.94 \text{ AUD}$ **A1**

Note: Do not award final **A1** if answer is not given correct to 2 dp, unless already penalized in part (a). Accept 133020.30 from use of exact value for PMT .

- (ii) amount of money paid: $120 \times 792.13 (= 95055.60)$ **(M1)**
 loan paid off: $170\,000 - 133019.94 (= 36980.06)$ **(M1)**
 interest paid: $(95\,055.60 - 36\,980.06 =) 58\,075.54 \text{ AUD}$ **A1**

Note: Allow 58075.60 or 58075.90 from use of some exact values from parts (a) and (b)(i). If their answer to part (b)(i) is greater than 170 000 then award at most **(M1)(M1)(A0)** for follow through in part (b)(ii).

[6 marks]

Total: [9 marks]

6. (a) $10 = \frac{2}{1-r}$ (M1)
 $r = 0.8$ A1
 [2 marks]

(b) $2 \times (0.8)^{n-1} < 0.5$ OR $2 \times (0.8)^{n-1} = 0.5$ (M1)
 $(n >) 7.212\dots$ (A1)
 $n = 8$ A1

Note: If $n = 7$ is seen, with or without seeing the value 7.212... then award **M1A1A0**.

[3 marks]

Total: [5 marks]

7. (a) 75 A1
 [1 mark]

(b) recognition that all entries add up to 120 (M1)
 $a = 120 - 6 - 13 - 26 - b$ OR $a = 75 - b$ A1
 [2 marks]

(c) (i) $\frac{6 \times 1 + 13 \times 2 + 26 \times 3 + (75 - b) \times 4 + b \times 5}{120} = 3.65$ (M1)(A1)

Note: Award (M1) for attempt to substitute into mean formula, LHS expression is sufficient for the M mark. Award (A1) for correct substitutions in one variable OR in two variables, followed by evidence of solving simultaneously with $a + b = 75$.

$(b =) 28$ A1

(ii) $120 -$ their part (c)(i) seen (e.g. 92 indicated on graph) (M1)
 84 A1

[5 marks]

Total: [8 marks]

8. (a) (i) a A1
(ii) the hill is at its steepest / largest slope of hill A1

[2 marks]

(b)

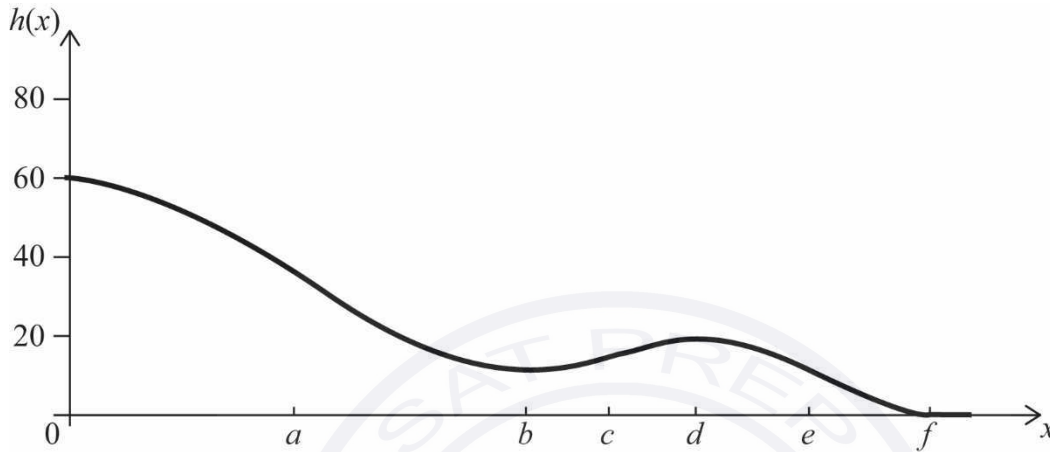

A1A1A1

Note: Award **(A1)** for decreasing function from 0 to b and d to f and increasing from b to d ; **(A1)** for minimum at b and max at d ; **(A1)** for starting at height of 60 and finishing at a height of 0 at f . If reasonable curvature not evident on graph (i.e. only straight lines used) award **A1A0A1**.

[3 marks]

Total: [5 marks]

9. (a)

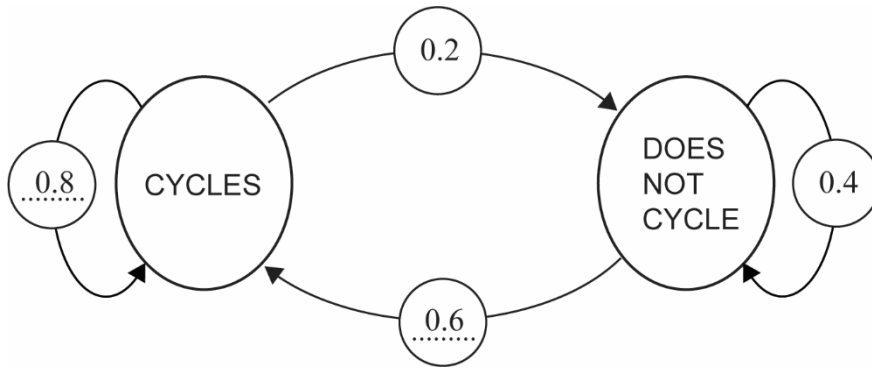

A1A1
[2 marks]

(b) $A = \begin{pmatrix} 0.8 & 0.6 \\ 0.2 & 0.4 \end{pmatrix}$

(A1)

$$A^{180} = \begin{pmatrix} 0.75 & 0.75 \\ 0.25 & 0.25 \end{pmatrix}$$

(M1)

0.75

A1

[3 marks]

Total: [5 marks]

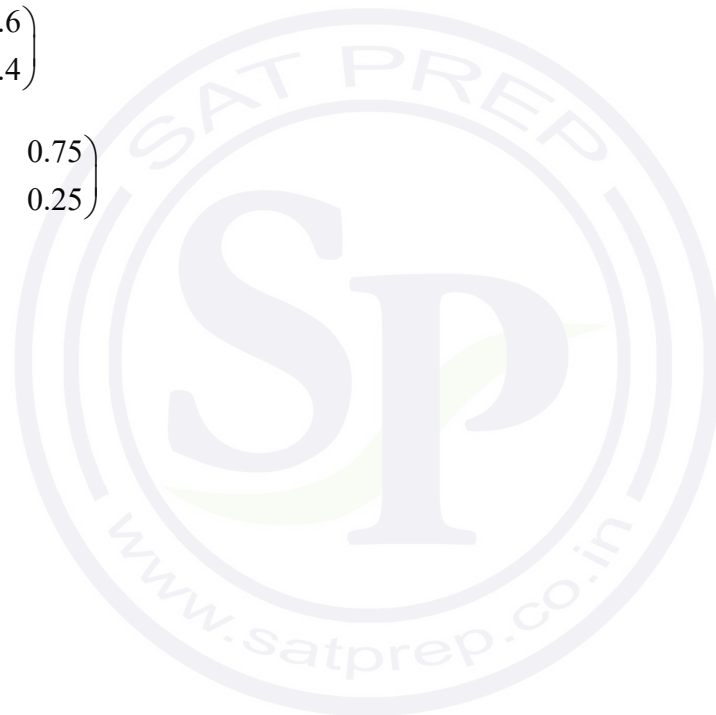

10. (a) $g(0) = 16$

M1A1

[2 marks]

(b)

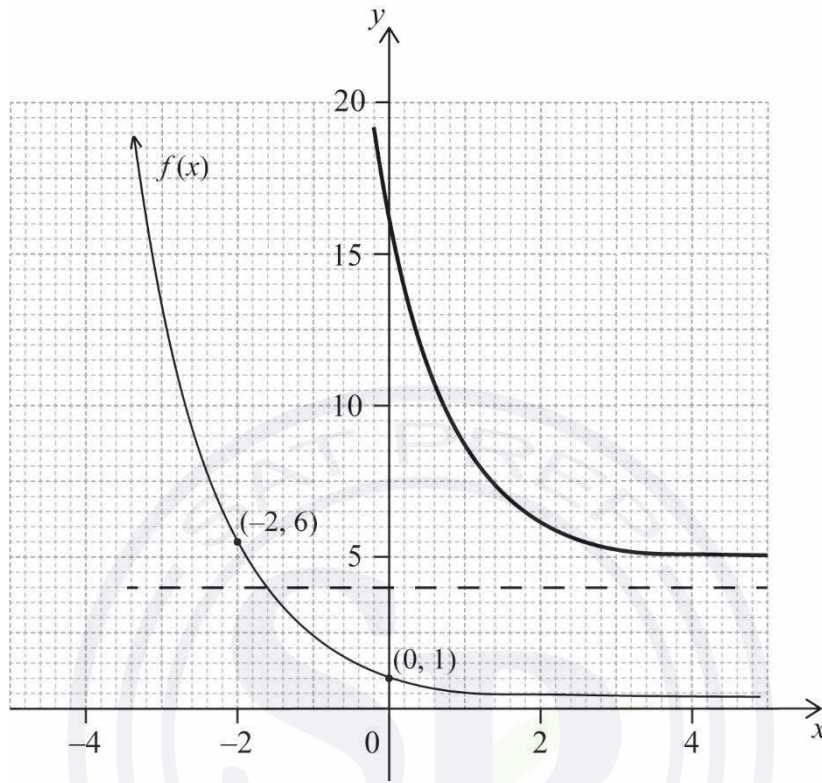

y -asymptote ($y = 4$)

concave up decreasing curve and passing through $(0, 16)$

A1

A1

[2 marks]

Total: [4 marks]

11. METHOD 1

attempt to find AC using cosine rule

$$7^2 = 10^2 + AC^2 - 2 \times 10 \times AC \times \cos 40^\circ$$

M1

(A1)

attempt to solve a quadratic equation

(M1)

$$AC = 4.888... \text{ AND } 10.432...$$

(A1)

Note: At least $AC = 4.888...$ must be seen, or implied by subsequent working.

$$\text{minimum area} = \frac{1}{2} \times 10 \times 4.888... \times \sin(40^\circ)$$

M1

Note: Do not award **M1** if incorrect value for minimizing the area has been chosen.

$$= 15.7 \text{ m}^2$$

A1

METHOD 2

attempt to find $\hat{A}CB$ using the sine Rule

$$\frac{\sin C}{10} = \frac{\sin 40}{7}$$

M1

(A1)

$$C = 66.674...^\circ \text{ OR } 113.325...^\circ$$

(A1)

EITHER

$$B = 180 - 40 - 113.325...$$

$$B = 26.675...^\circ$$

(A1)

$$\text{area} = \frac{1}{2} \times 10 \times 7 \times \sin(26.675...^\circ)$$

M1

OR

sine rule or cosine rule to find $AC = 4.888...$

(A1)

$$\text{minimum area} = \frac{1}{2} \times 10 \times 4.888... \times \sin(40^\circ)$$

M1

THEN

$$= 15.7 \text{ m}^2$$

A1

Note: Award **A0M1A0** if the wrong length AC or the wrong angle B selected but used correctly finding a value of 33.5 m^2 for the area.

Total: [6 marks]

12. (a) $m = -0.695$ (-0.695383...); $b = 4.63$ (4.62974...)

A1A1

[2 marks]

(b) $\ln x = -0.695(\ln 25) + 4.63$

M1

$\ln x = 2.39288...$

(A1)

$x = 10.9\%$

A1

[3 marks]

Total: [5 marks]

13. (a) $\left(\frac{dy}{dx} = e^0 - 1\right) = 0$

A1

[1 mark]

(b)

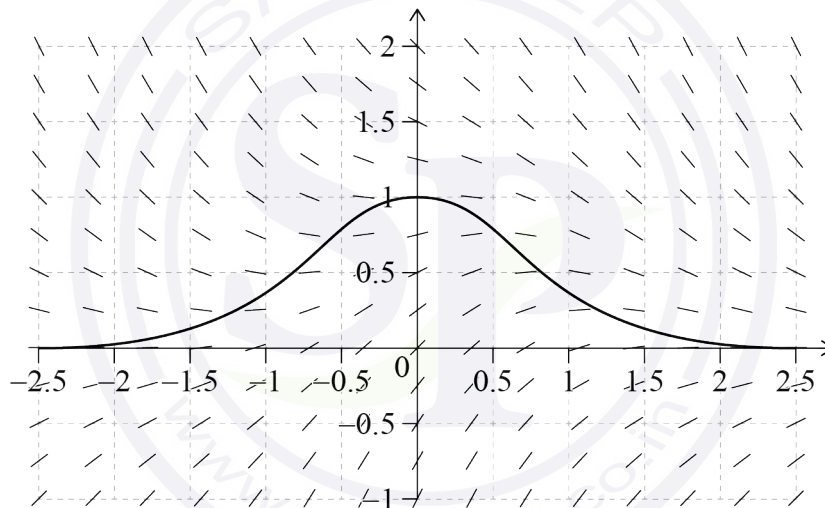

gradient = 0 at (0, 1)
correct shape

A1

A1

Note: Award second **A1** for horizontal asymptote of $y = 0$, and general symmetry about the y -axis.

[2 marks]

continued...

Question 13 continued

(c)

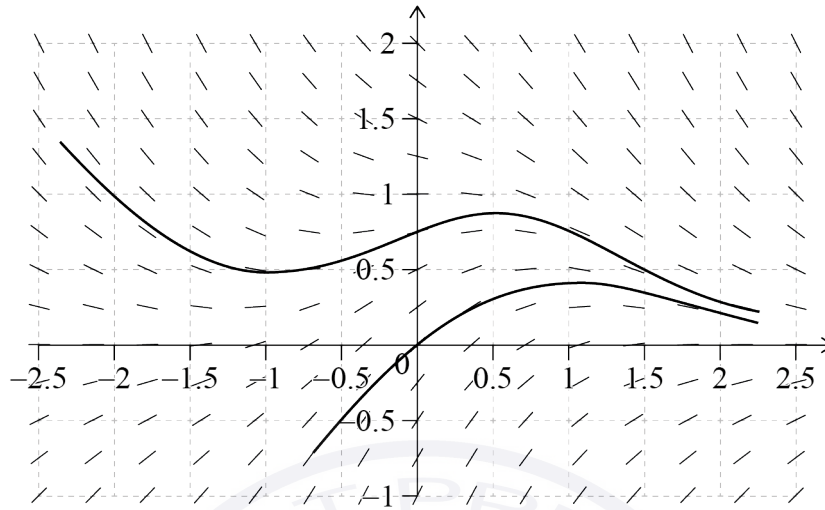

- (i) positive gradient at origin
correct shape

A1
A1

Note: Award second **A1** for a single maximum in 1st quadrant and tending toward an asymptote.

- (ii) positive gradient at (0, 0.75)
correct shape

A1
A1

Note: Award second **A1** for a single minimum in 2nd quadrant, single maximum in 1st quadrant and tending toward an asymptote.

[4 marks]
Total: [7 marks]

14. (a) let X be the random variable “the weight of a sack of potatoes”

$$P(X < 50)$$

$$= 0.588 \text{ kg } (0.587929\dots)$$

(M1)

A1

[2 marks]

- (b) $P(X < 49) = 0.25$

$$49.2 \text{ kg } (49.1929\dots)$$

(M1)

A1

[2 marks]

- (c) attempt to sum 10 independent random variables

(M1)

$$Y = \sum_{i=1}^{10} X_i \sim N(498, 10 \times 0.9^2)$$

(A1)

$$P(Y > 500) = 0.241$$

A1

[3 marks]

Total: [7 marks]

15. (a) $15 = 3 + 4r + 2r\theta$ **M1**
 $12 = 2r(2 + \theta)$ **A1**

Note: Award **A1** for any reasonable working leading to expected result e.g, factorizing r .

$$r = \frac{6}{2 + \theta}$$
AG

[2 marks]

- (b) (i) attempt to use sector area to find volume **(M1)**

$$\text{volume} = \frac{1}{2}r^2\theta \times 1$$

$$= \frac{1}{2} \times \frac{36}{(2 + \theta)^2} \times \theta \quad \left(= \frac{18\theta}{(2 + \theta)^2} \right)$$
A1

(ii) $\frac{dV}{d\theta} = \frac{(2 + \theta)^2 \times 18 - 36\theta(2 + \theta)}{(2 + \theta)^4}$ **M1A1A1**

$$\frac{dV}{d\theta} = \frac{36 - 18\theta}{(2 + \theta)^3}$$

(iii) $\frac{dV}{d\theta} = \frac{36 - 18\theta}{(2 + \theta)^3} = 0$ **M1**

Note: Award this **M1** for simplified version equated to zero. The simplified version may have been seen in part (b)(ii).

$$\theta = 2$$
A1

[7 marks]

Total: [9 marks]

16. (a) $\vec{OS} = \begin{pmatrix} 300 \\ 100 \end{pmatrix} + t \begin{pmatrix} -12 \\ 15 \end{pmatrix}$ A1

[1 mark]

(b) attempt to find the vector from L to S (M1)

$\vec{LS} = \begin{pmatrix} 171 \\ -183 \end{pmatrix} + t \begin{pmatrix} -12 \\ 15 \end{pmatrix}$ A1

EITHER

$|\vec{LS}| = \sqrt{(171-12t)^2 + (15t-183)^2}$ (M1)(A1)

minimize to find t on GDC (M1)

OR

S closest when $\vec{LS} \cdot \begin{pmatrix} -12 \\ 15 \end{pmatrix} = 0$ (M1)

$\left(\begin{pmatrix} 171 \\ -183 \end{pmatrix} + t \begin{pmatrix} -12 \\ 15 \end{pmatrix} \right) \cdot \begin{pmatrix} -12 \\ 15 \end{pmatrix} = 0$
 $-2052 + 144t - 2745 + 225t = 0$ (M1)(A1)

OR

S closest when $\vec{LS} \cdot \begin{pmatrix} -12 \\ 15 \end{pmatrix} = 0$ (M1)

$\vec{LS} = \begin{pmatrix} 5k \\ 4k \end{pmatrix}$
 $\vec{OS} = \begin{pmatrix} 129 + 5k \\ 283 + 4k \end{pmatrix}$ (A1)

$\begin{pmatrix} 129 + 5k \\ 283 + 4k \end{pmatrix} = \begin{pmatrix} 300 - 12t \\ 100 + 15t \end{pmatrix}$
 Solving simultaneously (M1)

THEN

$t = 13$ A1
[6 marks]

(c) the alarm will sound A1

$|\vec{LS}| = 19.2\dots < 20$ R1

Note: Do not award **A1R0**.

[2 marks]
 Total: [9 marks]

17. (a) attempt to use $V = \pi \int_a^b x^2 \, dy$ (M1)

$x = e^{\frac{y}{6}}$ or any reasonable attempt to find x in terms of y (M1)

$V = \pi \int_0^h e^{\frac{y}{3}} \, dy$ A1

Note: Correct limits must be seen for the **A1** to be awarded.

$= \pi \left[3e^{\frac{y}{3}} \right]_0^h$ (A1)

Note: Condone the absence of limits for this **A1** mark.

$= 3\pi \left[e^{\frac{h}{3}} - e^0 \right]$ A1

$= 3\pi \left[e^{\frac{h}{3}} - 1 \right]$ AG

Note: If the variable used in the integral is x instead of y (i.e. $V = \pi \int_0^h e^{\frac{x}{3}} \, dx$) and the candidate has not stated that they are interchanging x and y then award at most **M1M1A0A1A1AG**.

[5 marks]

(b) maximum volume when $h = 9$ cm (M1)
 max volume = 180 cm^3 A1

[2 marks]
 Total: [7 marks]

Markscheme

May 2021

**Mathematics:
applications and interpretation**

Higher level

Paper 1

© International Baccalaureate Organization 2021

All rights reserved. No part of this product may be reproduced in any form or by any electronic or mechanical means, including information storage and retrieval systems, without the prior written permission from the IB. Additionally, the license tied with this product prohibits use of any selected files or extracts from this product. Use by third parties, including but not limited to publishers, private teachers, tutoring or study services, preparatory schools, vendors operating curriculum mapping services or teacher resource digital platforms and app developers, whether fee-covered or not, is prohibited and is a criminal offense.

More information on how to request written permission in the form of a license can be obtained from <https://ibo.org/become-an-ib-school/ib-publishing/licensing/applying-for-a-license/>.

© Organisation du Baccalauréat International 2021

Tous droits réservés. Aucune partie de ce produit ne peut être reproduite sous quelque forme ni par quelque moyen que ce soit, électronique ou mécanique, y compris des systèmes de stockage et de récupération d'informations, sans l'autorisation écrite préalable de l'IB. De plus, la licence associée à ce produit interdit toute utilisation de tout fichier ou extrait sélectionné dans ce produit. L'utilisation par des tiers, y compris, sans toutefois s'y limiter, des éditeurs, des professeurs particuliers, des services de tutorat ou d'aide aux études, des établissements de préparation à l'enseignement supérieur, des fournisseurs de services de planification des programmes d'études, des gestionnaires de plateformes pédagogiques en ligne, et des développeurs d'applications, moyennant paiement ou non, est interdite et constitue une infraction pénale.

Pour plus d'informations sur la procédure à suivre pour obtenir une autorisation écrite sous la forme d'une licence, rendez-vous à l'adresse <https://ibo.org/become-an-ib-school/ib-publishing/licensing/applying-for-a-license/>.

© Organización del Bachillerato Internacional, 2021

Todos los derechos reservados. No se podrá reproducir ninguna parte de este producto de ninguna forma ni por ningún medio electrónico o mecánico, incluidos los sistemas de almacenamiento y recuperación de información, sin la previa autorización por escrito del IB. Además, la licencia vinculada a este producto prohíbe el uso de todo archivo o fragmento seleccionado de este producto. El uso por parte de terceros —lo que incluye, a título enunciativo, editoriales, profesores particulares, servicios de apoyo académico o ayuda para el estudio, colegios preparatorios, desarrolladores de aplicaciones y entidades que presten servicios de planificación curricular u ofrezcan recursos para docentes mediante plataformas digitales—, ya sea incluido en tasas o no, está prohibido y constituye un delito.

En este enlace encontrará más información sobre cómo solicitar una autorización por escrito en forma de licencia: <https://ibo.org/become-an-ib-school/ib-publishing/licensing/applying-for-a-license/>.

Instructions to Examiners

Abbreviations

- M** Marks awarded for attempting to use a correct **Method**.
- A** Marks awarded for an **Answer** or for **Accuracy**; often dependent on preceding **M** marks.
- R** Marks awarded for clear **Reasoning**.
- AG** Answer given in the question and so no marks are awarded.
- FT** Follow through. The practice of awarding marks, despite candidate errors in previous parts, for their correct methods/answers using incorrect results.

Using the markscheme

1 General

Award marks using the annotations as noted in the markscheme eg **M1**, **A2**.

2 Method and Answer/Accuracy marks

- Do **not** automatically award full marks for a correct answer; all working **must** be checked, and marks awarded according to the markscheme.
- It is generally not possible to award **M0** followed by **A1**, as **A** mark(s) depend on the preceding **M** mark(s), if any.
- Where **M** and **A** marks are noted on the same line, e.g. **M1A1**, this usually means **M1** for an **attempt** to use an appropriate method (e.g. substitution into a formula) and **A1** for using the **correct** values.
- Where there are two or more **A** marks on the same line, they may be awarded independently; so if the first value is incorrect, but the next two are correct, award **A0A1A1**.
- Where the markscheme specifies **A3**, **M2** etc., do **not** split the marks, unless there is a note.
- The response to a “show that” question does not need to restate the **AG** line, unless a **Note** makes this explicit in the markscheme.
- Once a correct answer to a question or part question is seen, ignore further working even if this working is incorrect and/or suggests a misunderstanding of the question. This will encourage a uniform approach to marking, with less examiner discretion. Although some candidates may be advantaged for that specific question item, it is likely that these candidates will lose marks elsewhere too.
- An exception to the previous rule is when an incorrect answer from further working is used **in a subsequent part**. For example, when a correct exact value is followed by an incorrect decimal approximation in the first part and this approximation is then used in the second part. In this situation, award **FT** marks as appropriate but do not award the final **A1** in the first part. Examples:

	Correct answer seen	Further working seen	Any FT issues?	Action
1.	$8\sqrt{2}$	5.65685... (incorrect decimal value)	No. Last part in question.	Award A1 for the final mark (condone the incorrect further working)
2.	$\frac{35}{72}$	0.468111... (incorrect decimal value)	Yes. Value is used in subsequent parts.	Award A0 for the final mark (and full FT is available in subsequent parts)

3 Implied marks

Implied marks appear in **brackets e.g. (M1)**, and can only be awarded if **correct** work is seen or implied by subsequent working/answer.

4 Follow through marks (only applied after an error is made)

Follow through (**FT**) marks are awarded where an incorrect answer from one **part** of a question is used correctly in **subsequent** part(s) (e.g. incorrect value from part (a) used in part (d) or incorrect value from part (c)(i) used in part (c)(ii)). Usually, to award **FT** marks, **there must be working present** and not just a final answer based on an incorrect answer to a previous part. However, if all the marks awarded in a subsequent part are for the answer or are implied, then **FT** marks should be awarded for *their* correct answer, even when working is not present.

For example: following an incorrect answer to part (a) that is used in subsequent parts, where the markscheme for the subsequent part is **(M1)A1**, it is possible to award full marks for *their* correct answer, **without working being seen**. For longer questions where all but the answer marks are implied this rule applies but may be overwritten by a **Note** in the Markscheme.

- Within a question part, once an **error** is made, no further **A** marks can be awarded for work which uses the error, but **M** marks may be awarded if appropriate.
- If the question becomes much simpler because of an error then use discretion to award fewer **FT** marks, by reflecting on what each mark is for and how that maps to the simplified version.
- If the error leads to an inappropriate value (e.g. probability greater than 1, $\sin \theta = 1.5$, non-integer value where integer required), do not award the mark(s) for the final answer(s).
- The markscheme may use the word “their” in a description, to indicate that candidates may be using an incorrect value.
- If the candidate’s answer to the initial question clearly contradicts information given in the question, it is not appropriate to award any **FT** marks in the subsequent parts. This includes when candidates fail to complete a “show that” question correctly, and then in subsequent parts use their incorrect answer rather than the given value.
- Exceptions to these **FT** rules will be explicitly noted on the markscheme.
- If a candidate makes an error in one part but gets the correct answer(s) to subsequent part(s), award marks as appropriate, unless the command term was “Hence”.

5 Mis-read

If a candidate incorrectly copies values or information from the question, this is a mis-read (**MR**). A candidate should be penalized only once for a particular misread. Use the **MR** stamp to indicate that this has been a misread and do not award the first mark, even if this is an **M** mark, but award all others as appropriate.

- If the question becomes much simpler because of the **MR**, then use discretion to award fewer marks.
- If the **MR** leads to an inappropriate value (e.g. probability greater than 1, $\sin \theta = 1.5$, non-integer value where integer required), do not award the mark(s) for the final answer(s).
- Miscopying of candidates' own work does **not** constitute a misread, it is an error.
- If a candidate uses a correct answer, to a "show that" question, to a higher degree of accuracy than given in the question, this is NOT a misread and full marks may be scored in the subsequent part.
- **MR** can only be applied when work is seen. For calculator questions with no working and incorrect answers, examiners should **not** infer that values were read incorrectly.

6 Alternative methods

Candidates will sometimes use methods other than those in the markscheme. Unless the question specifies a method, other correct methods should be marked in line with the markscheme. If the command term is 'Hence' and not 'Hence or otherwise' then alternative methods are not permitted unless covered by a note in the mark scheme.

- Alternative methods for complete questions are indicated by **METHOD 1**, **METHOD 2**, etc.
- Alternative solutions for parts of questions are indicated by **EITHER . . . OR**.

7 Alternative forms

Unless the question specifies otherwise, **accept** equivalent forms.

- As this is an international examination, accept all alternative forms of **notation** for example 1.9 and 1,9 or 1000 and 1,000 and 1.000.
- Do not accept final answers written using calculator notation. However, **M** marks and intermediate **A** marks can be scored, when presented using calculator notation, provided the evidence clearly reflects the demand of the mark.
- In the markscheme, equivalent **numerical** and **algebraic** forms will generally be written in brackets immediately following the answer.
- In the markscheme, some **equivalent** answers will generally appear in brackets. Not all equivalent notations/answers/methods will be presented in the markscheme and examiners are asked to apply appropriate discretion to judge if the candidate work is equivalent.

8 Format and accuracy of answers

If the level of accuracy is specified in the question, a mark will be linked to giving the answer to the required accuracy. If the level of accuracy is not stated in the question, the general rule applies to final answers: *unless otherwise stated in the question all numerical answers must be given exactly or correct to three significant figures.*

Where values are used in subsequent parts, the markscheme will generally use the exact value, however candidates may also use the correct answer to 3 sf in subsequent parts. The markscheme will often explicitly include the subsequent values that come “*from the use of 3 sf values*”.

Simplification of final answers: Candidates are advised to give final answers using good mathematical form. In general, for an **A** mark to be awarded, arithmetic should be completed, and

any values that lead to integers should be simplified; for example, $\sqrt{\frac{25}{4}}$ should be written as $\frac{5}{2}$.

An exception to this is simplifying fractions, where lowest form is not required (although the numerator and the denominator must be integers); for example, $\frac{10}{4}$ may be left in this form or

written as $\frac{5}{2}$. However, $\frac{10}{5}$ should be written as 2, as it simplifies to an integer.

Algebraic expressions should be simplified by completing any operations such as addition and multiplication, e.g. $4e^{2x} \times e^{3x}$ should be simplified to $4e^{5x}$, and $4e^{2x} \times e^{3x} - e^{4x} \times e^x$ should be simplified to $3e^{5x}$. Unless specified in the question, expressions do not need to be factorized, nor do factorized expressions need to be expanded, so $x(x+1)$ and $x^2 + x$ are both acceptable.

Please note: intermediate **A** marks do NOT need to be simplified.

9 Calculators

A GDC is required for this paper, but If you see work that suggests a candidate has used any calculator not approved for IB DP examinations (eg CAS enabled devices), please follow the procedures for malpractice.

10. Presentation of candidate work

Crossed out work: If a candidate has drawn a line through work on their examination script, or in some other way crossed out their work, do not award any marks for that work unless an explicit note from the candidate indicates that they would like the work to be marked.

More than one solution: Where a candidate offers two or more different answers to the same question, an examiner should only mark the first response unless the candidate indicates otherwise. If the layout of the responses makes it difficult to judge, examiners should apply appropriate discretion to judge which is “first”.

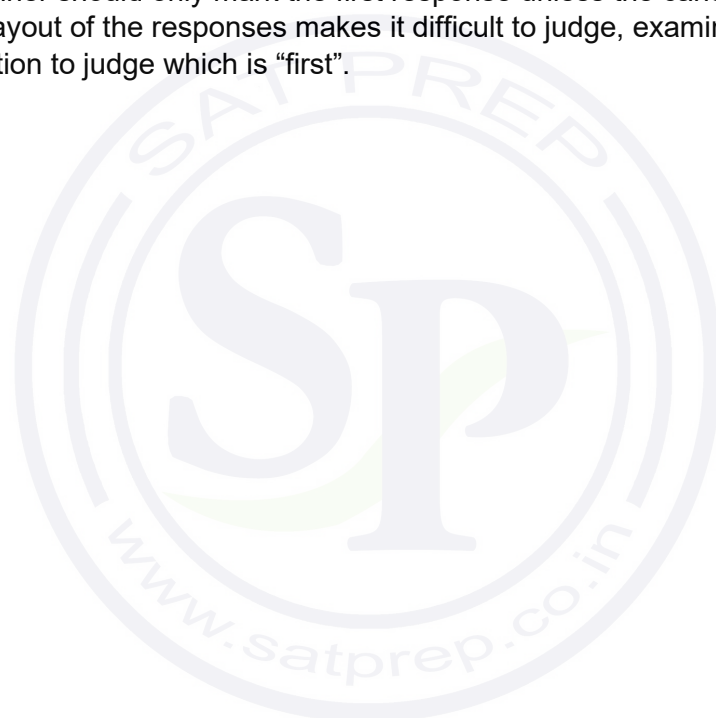

1. (a) gradient $AB = \frac{4}{12} \left(\frac{1}{3} \right)$ (A1)
 midpoint $AB: (8, 22)$ (A1)

gradient of bisector $= -\frac{1}{\text{gradient } AB} = -3$ (M1)

perpendicular bisector: $22 = -3 \times 8 + b$ OR $(y - 22) = -3(x - 8)$ (M1)

perpendicular bisector: $y = -3x + 46$ A1

[5 marks]

- (b) attempt to solve simultaneous equations (M1)

$x + 4 = -3x + 46$

$(10.5, 14.5)$

A1

[2 marks]

Total [7 marks]

2. (a) $(f(-7) =) 8$ and $(f(7) =) 1$ (A1)
 range is $f(x) \leq 1, f(x) \geq 8$ A1A1

Note: Award at most **A1A1A0** if strict inequalities are used.

- (b) interchanging x, y at any stage (A1)

$y = 2 - \frac{12}{x+5}$

$\frac{12}{x+5} = 2 - y$

$\frac{12}{2-y} = x+5$

$\frac{12}{2-y} - 5 = x$

$(f^{-1}(x) =) \frac{12}{2-x} - 5 \left(= \frac{2+5x}{2-x} \right)$ A1

[3 marks]

- (c) range is $-7 \leq f^{-1}(x) \leq 7, f^{-1}(x) \neq -5$ A1

[1 mark]

Total [7 marks]

3. (a) (let μ_c = population mean for chinchilla rabbits, μ_s = population mean for sable rabbits)

$$H_0 : \mu_c = \mu_s$$

A1

$$H_1 : \mu_c > \mu_s$$

A1

Note: Accept an equivalent statement in words, must include mean and reference to “**population** mean” / “mean for **all** chinchilla rabbits” for the first **A1** to be awarded. The terms “*on average*” and “*generally*” are also acceptable to indicate populations.
Do not accept an imprecise “*the means are equal*”.

[2 marks]

- (b) p -value = 0.0408 (0.0408065...)

A2

Note: Award **A1** for an answer of 0.041565..., from “unpooled” settings on GDC.

[2 marks]

- (c) $0.0408 < 0.05$.

R1

(there is sufficient evidence to) reject (or not accept) H_0

A1

(there is sufficient evidence to suggest that chinchilla rabbits are (generally) heavier than sable rabbits)

Note: Do not award **R0A1**. Accept ‘accept H_1 ’.

[2 marks]

Total [6 marks]

4. (a) $AC = \frac{380}{\tan 25^\circ}$ OR $AC = \sqrt{\left(\frac{380}{\sin 25^\circ}\right)^2 - 380^2}$ OR $\frac{380}{\sin 25^\circ} = \frac{AC}{\sin 65^\circ}$ (M1)

$AC = 815 \text{ m (814.912...)}$ A1
[2 marks]

(b) **METHOD 1**
attempt to find AB (M1)

$AB = \frac{380}{\tan 40^\circ}$
 $= 453 \text{ m (452.866...)}$ (A1)

$BC = 814.912... - 452.866...$
 $= 362 \text{ m (362.046...)}$ A1

METHOD 2
attempt to find HB (M1)

$HB = \frac{380}{\sin 40^\circ}$
 $591 \text{ m (= 591.175...)}$ (A1)

$BC = \frac{591.175... \times \sin 15^\circ}{\sin 25^\circ}$
 $= 362 \text{ m (362.046...)}$ A1
[3 marks]

(c) $362.046... \times 4$
 $= 1450 \text{ m h}^{-1} \text{ (1448.18...)}$ A1
[1 mark]

Total [6 marks]

5. (a) $£495 \times 0.9^5 = £292$ (£292.292...)

(M1)A1

[2 marks]

(b) $495 \times 0.9^k = 2200 \times 0.85^k$
 $k = 26.1$ (26.0968...)

(M1)

A1

Note: Award **M1A0** for $k - 1$ in place of k .

[2 marks]

(c) depreciation rates unlikely to be constant (especially over a long time period)

R1

Note: Accept reasonable answers based on the magnitude of k or the fact that “value” depends on factors other than time.

[1 mark]

Total [5 marks]



6. (a) 3 A1

Note: Accept (3, 0) seen.

[1 mark]

(b) **METHOD 1**

$$0 = 4a - 2b + c, \quad 0 = 9a + 3b + c, \quad -\frac{25}{2} = \frac{1}{4}a + \frac{1}{2}b + c \quad (M1)(A1)$$

(i) 2 A1

(ii) -2 A1

(iii) -12 A1

Note: Award the (M1)(A1) if at least one correct value is seen.
Do not apply **FT** from part (a) if workings are not shown.

METHOD 2

$$-12.5 = a(0.5 + 2)(0.5 - 3) \quad (M1)$$

(i) $a = 2$ A1

$$0 = 2x(3)^2 + 3b + c$$

$$0 = 2x(-2)^2 + (-2)b + c \quad (M1)$$

(ii) $b = -2$ A1

(iii) $c = -12$ A1

[5 marks]

(c) $x = 0.5$ A1

Note: Do not **FT** from their part (b), this is a contradiction with the diagram.

[1 mark]

Total [7 marks]

7. (a) recognition of geometric sequence eg $r = 0.82$ **(M1)**

$$S_{10} = \frac{450(1 - 0.82^{10})}{1 - 0.82} \quad \text{(A1)}$$

$$= 2160 \text{ m (2156.37...)} \quad \text{A1}$$

[3 marks]

- (b) $S_{\infty} = \frac{450}{1 - 0.82}$ **(M1)**

$$= 2500 < 2520 \text{ so the balloon will not reach the required height.} \quad \text{A1}$$

[2 marks]

- (c) horizontal motion not taken into account,
rate of cooling will not likely be linear,
balloon is considered a point mass / size of balloon not considered,
effects of wind/weather unlikely to be consistent,
a discrete model has been used, whereas a continuous one may offer greater accuracy

R1

Note: Accept any other sensible answer.

[1 mark]

Total [6 marks]

8. (a) setting a dot product of the direction vectors equal to zero (M1)

$$\begin{pmatrix} p \\ 2p \\ 4 \end{pmatrix} \cdot \begin{pmatrix} p+4 \\ 4 \\ -7 \end{pmatrix} = 0$$

$$p(p+4) + 8p - 28 = 0 \quad \text{(A1)}$$

$$p^2 + 12p - 28 = 0$$

$$(p+14)(p-2) = 0$$

$$p = -14, p = 2 \quad \text{A1}$$

[3 marks]

- (b) $p = -14 \Rightarrow$

$$L_1 : r = \begin{pmatrix} 2 \\ -5 \\ -3 \end{pmatrix} + \lambda \begin{pmatrix} -14 \\ -28 \\ 4 \end{pmatrix}$$

$$L_2 : r = \begin{pmatrix} 14 \\ 7 \\ -2 \end{pmatrix} + \mu \begin{pmatrix} -10 \\ 4 \\ -7 \end{pmatrix}$$

a common point would satisfy the equations

$$2 - 14\lambda = 14 - 10\mu$$

$$-5 - 28\lambda = 7 + 4\mu$$

$$-3 + 4\lambda = -2 - 7\mu$$

(M1)

METHOD 1

solving the first two equations simultaneously

$$\lambda = -\frac{1}{2}, \mu = \frac{1}{2}$$

A1

substitute into the third equation:

M1

$$-3 + 4\left(-\frac{1}{2}\right) \neq -2 + \frac{1}{2}(-7)$$

so lines do not intersect.

R1

Note: Accept equivalent methods based on the order in which the equations are considered.

METHOD 2

attempting to solve the equations using a GDC

M1

GDC indicates no solution

A1

so lines do not intersect

R1

[4 marks]

Total [7 marks]

9. (a) $\left(\frac{74+97+91+86+112}{5}\right) = 92$ **A1**

[1 mark]

- (b) (i) H_0 : The data satisfies the model **A1**
 H_1 : The data does not satisfy the model **A1**

Note: Do not accept " H_0 : The same number of copies will be sold each day" but accept a similar statement if the word 'expect' or 'expected' is included. Similarly for H_1 .

(ii) 4 **A1**

(iii) $\chi^2_{\text{calc}} = 8.54$ (8.54347...) **OR** $p\text{-value} = 0.0736$ (0.0735802...) **A2**

8.54 < 9.49 **OR** 0.0736 > 0.05 **R1**

therefore there is insufficient evidence to reject H_0 **A1**

(i.e. the data satisfies the model)

Note: Do not award **ROA1**. Accept "accept" or "do not reject" in place of "insufficient evidence to reject". Award the **R1** for comparing their p -value with 0.05 or their χ^2 value with 9.49 and then **FT** their final conclusion.

[7 marks]

Total [8 marks]

10. (a) $\bar{x} = \frac{\sum x}{n} = \frac{2506}{30} = 83.5 \text{ (83.5333...)}$

A1

[1 mark]

(b)
$$s_{n-1}^2 = \frac{\sum x^2 - \frac{(\sum x)^2}{n}}{n-1} = \frac{209738 - \frac{2506^2}{30}}{29}$$

 $= 13.9 \text{ (13.9126...)}$

(M1)

A1

[2 marks]

(c) $(82.1, 84.9) \text{ (82.1405..., 84.9261...)}$

A2

[2 marks]

(d) 85 is outside the confidence interval and therefore Talha would suggest that the manufacturer's claim is incorrect

R1

Note: The conclusion must refer back to the original claim.

Allow use of a two sided t -test giving a p -value rounding to $0.04 < 0.05$ and therefore Talha would suggest that the manufacturer's claims in incorrect.

[1 mark]

Total [6 marks]

11. (a) Odd vertices are A, B, D, H
Consider pairings:

A1
M1

Note: Award **(M1)** if there are four vertices not necessarily all correct.

AB DH has shortest route AD, DE, EB and DE, EH,
so repeated edges $(19+16+19)+(16+27)=97$

Note: Condone AB in place of AD, DE, EB giving $56+(16+27)=99$.

AD BH has shortest route AD and BE, EH,
so repeated edges $19+(19+27)=65$

AH BD has shortest route AD, DE, EH and BE, ED,
so repeated edges $(19+16+27)+(19+16)=97$

A2

Note: Award **A1** if only one or two pairings are correctly considered.

so best pairing is AD, BH
weight of route is therefore $582+65=647$

A1
[5 marks]

- (b) least value of the pairings is 19 therefore repeat AD

R1

B and H

A1

Note: Do not award **R0A1**.

[2 marks]

Total [7 marks]

12. (a) (i) $z_1^3 = 27e^{\frac{i\pi}{4}} (= 27e^{0.785398\dots i})$

A1A1

Note: Award **A1** for 27 and **A1** for the angle in the correct form.

(ii) $\left(\frac{z_1}{z_2}\right)^4 = \left(\frac{81}{16}\right)e^{\frac{i\pi}{2}} (= 5.0625e^{1.57079\dots i})$

A1A2

Note: Award **A1** for $\frac{81}{16}$, **A2** for the angle in the correct form and

A1 for the angle in incorrect form e.g. $\text{cis } \frac{\pi}{2}$ and/or $\frac{5\pi}{2}$.

Award **A1** if i is given in place of $\text{cis } \frac{\pi}{2}$.

[5 marks]

(b) $z_1 z_2 = 6 \text{cis} \left(\frac{3\pi}{4} + \frac{n\pi}{16} \right)$

(M1)

$= 6 \text{cis} \left(\frac{12\pi + n\pi}{16} \right)$

$12\pi + n\pi = 32\pi$

$n = 20$

(M1)

A1

[3 marks]

Total [8 marks]

13.

(a) transition matrix is

<i>A</i>	<i>B</i>	<i>C</i>	<i>D</i>	<i>E</i>	<i>F</i>
<i>A</i>	$\left(\begin{array}{cccccc} 0 & \frac{1}{3} & \frac{1}{2} & 0 & 0 & 0 \\ \frac{1}{3} & 0 & 0 & 0 & 0 & \frac{1}{5} \\ 0 & \frac{2}{3} & 0 & \frac{1}{2} & \frac{1}{2} & \frac{1}{5} \\ 0 & 0 & \frac{1}{2} & 0 & \frac{1}{2} & \frac{2}{5} \\ \frac{1}{3} & 0 & 0 & 0 & 0 & \frac{1}{5} \\ \frac{1}{3} & 0 & 0 & \frac{1}{2} & 0 & 0 \end{array} \right)$				

M1A1A1

Note: Allow the transposed matrix.

Award **M1** for a 6x6 matrix with all values between 0 and 1, and all columns (or rows if transposed) adding up to 1, award **A1** for one correct row (or column if transposed) and **A1** for all rows (or columns if transposed) correct.

[3 marks]

(b) attempting to raise the transition matrix to a large power **(M1)**

steady state vector is

$\left(\begin{array}{c} (0.157) \\ (0.0868) \\ (0.256) \\ (0.241) \\ (0.0868) \\ 0.173 \end{array} \right)$	(A1)
--	-------------

so percentage of time spent at vertex F is 17.3% **A1**

Note: Accept 17.2%.

[3 marks]

(c) the model assumes instantaneous travel from junction to junction, and hence the answer obtained would be an overestimate **R1**
OR **R1**
 the mouse may eat the sugar over time **R1**
 and hence the probabilities would change **R1**

Note: Accept any other sensible answer.

[2 marks]

Total [7 marks]

14. (a) $\begin{pmatrix} 7 & -10 \\ 2 & -3 \end{pmatrix} \begin{pmatrix} 6 \\ -2 \end{pmatrix} + \begin{pmatrix} -5 \\ 4 \end{pmatrix}$ **(M1)**
 $= \begin{pmatrix} 57 \\ 22 \end{pmatrix}$ **OR** (57, 22) **A1**

[2 marks]

(b) $\begin{pmatrix} 2p \\ 2q \end{pmatrix} = \begin{pmatrix} 7 & -10 \\ 2 & -3 \end{pmatrix} \begin{pmatrix} p \\ q \end{pmatrix} + \begin{pmatrix} -5 \\ 4 \end{pmatrix}$ **(M1)**
 $7p - 10q - 5 = 2p$
 $2p - 3q + 4 = 2q$ **(A1)**
 solve simultaneously:
 $p = 13, q = 6$ **A1**

Note: Award **A0** if 13 and 6 are not labelled or are labelled the other way around.

[3 marks]

(c) $\det \begin{pmatrix} 7 & -10 \\ 2 & -3 \end{pmatrix} = -1$ **OR** $\left| \det \begin{pmatrix} 7 & -10 \\ 2 & -3 \end{pmatrix} \right| = 1$ **A1**

scale factor of image area is therefore $(|-1| =) 1$ (and the translation does not affect the area)

A1
 [2 marks]

Total [7 marks]

15. (a) $H_0 : m = 110$, $H_1 : m > 110$

A1

Note: Accept other appropriate variables for the mean.
Accept 22 in place of 110.

[1 mark]

(b) $P(X \geq 128) = 0.05024$

(M1)(A1)

$P(X \geq 129) = 0.04153$

(M1)

(probability of making a type I error is) 0.0415

A1

Note: If other probabilities are seen, the final **A1** cannot be awarded unless 0.0415 is clearly identified as the final answer.

[4 marks]

(c) $X \sim \text{Po}(110)$

$P(X \geq 126) = 0.072 > 0.05$ **OR** recognizing $126 < 129$ or ≤ 128

R1

so there is insufficient evidence to reject H_0

A1

(ie there is insufficient evidence to suggest that the number of coffees being sold has increased)

Note: Accept 'Accept H_0 '.
Do not award **R0A1**.

[2 marks]

Total [7 marks]

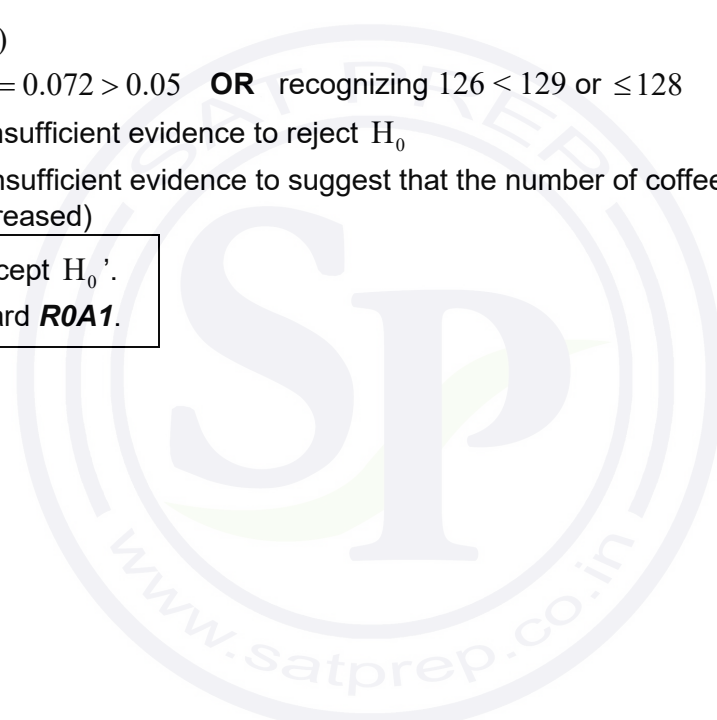

16. (a) $x_n = x_{n-1} + h f(x_{n-1}, t_{n-1})$
 $h = 0.1, f(x, t) = x \cos t (e^{-\sin t})$

$x_n = x_{n-1} + 0.1x_{n-1} \cos t_{n-1} (e^{-\sin t_{n-1}})$ (M1)

Note: Award **M1** for a valid start.

n	t_n	x_n
0	0	0.367879
1	0.1	0.404667
2	0.2	0.441106
3	0.3	0.476548

(A1)

Note: Award **A1** for a correct x value when $n = 1$.

$x(0.3) \approx 0.477$ (0.476548...) A1
[3 marks]

(b) **EITHER**

$\int \frac{dx}{x} = \int \cos t (e^{-\sin t}) dt (+c)$ M1

$\ln x = -e^{-\sin t} + c$ A1

$t = 0, x = \frac{1}{e} \Rightarrow c = 0$ M1

$x = e^{(-e^{-\sin t})}$
 $x(0.3) \approx 0.475140...$ A1

OR

$\int_{1/e}^x \frac{du}{u} = \int_0^{0.3} \cos t (e^{-\sin t}) dt$ M1

$[\ln u]_{1/e}^x = 0.255855... \text{ (from GDC)}$ A1

$\ln x + 1 = 0.255855...$

$\ln x = -0.744145...$ A1

$x = e^{-0.744145} = 0.475140....$ A1

THEN

percentage error = $\left| \frac{0.476548... - 0.475140...}{0.475140...} \right| \times 100 = 0.296\% \text{ (2.96192...)} \quad \text{A1}$

Note: If candidates do not attempt to find c , they may score **M1A0M0A1A1**.

[5 marks]

Total [8 marks]

Markscheme

May 2021

**Mathematics:
applications and interpretation**

Higher level

Paper 1

© International Baccalaureate Organization 2021

All rights reserved. No part of this product may be reproduced in any form or by any electronic or mechanical means, including information storage and retrieval systems, without the prior written permission from the IB. Additionally, the license tied with this product prohibits use of any selected files or extracts from this product. Use by third parties, including but not limited to publishers, private teachers, tutoring or study services, preparatory schools, vendors operating curriculum mapping services or teacher resource digital platforms and app developers, whether fee-covered or not, is prohibited and is a criminal offense.

More information on how to request written permission in the form of a license can be obtained from <https://ibo.org/become-an-ib-school/ib-publishing/licensing/applying-for-a-license/>.

© Organisation du Baccalauréat International 2021

Tous droits réservés. Aucune partie de ce produit ne peut être reproduite sous quelque forme ni par quelque moyen que ce soit, électronique ou mécanique, y compris des systèmes de stockage et de récupération d'informations, sans l'autorisation écrite préalable de l'IB. De plus, la licence associée à ce produit interdit toute utilisation de tout fichier ou extrait sélectionné dans ce produit. L'utilisation par des tiers, y compris, sans toutefois s'y limiter, des éditeurs, des professeurs particuliers, des services de tutorat ou d'aide aux études, des établissements de préparation à l'enseignement supérieur, des fournisseurs de services de planification des programmes d'études, des gestionnaires de plateformes pédagogiques en ligne, et des développeurs d'applications, moyennant paiement ou non, est interdite et constitue une infraction pénale.

Pour plus d'informations sur la procédure à suivre pour obtenir une autorisation écrite sous la forme d'une licence, rendez-vous à l'adresse <https://ibo.org/become-an-ib-school/ib-publishing/licensing/applying-for-a-license/>.

© Organización del Bachillerato Internacional, 2021

Todos los derechos reservados. No se podrá reproducir ninguna parte de este producto de ninguna forma ni por ningún medio electrónico o mecánico, incluidos los sistemas de almacenamiento y recuperación de información, sin la previa autorización por escrito del IB. Además, la licencia vinculada a este producto prohíbe el uso de todo archivo o fragmento seleccionado de este producto. El uso por parte de terceros —lo que incluye, a título enunciativo, editoriales, profesores particulares, servicios de apoyo académico o ayuda para el estudio, colegios preparatorios, desarrolladores de aplicaciones y entidades que presten servicios de planificación curricular u ofrezcan recursos para docentes mediante plataformas digitales—, ya sea incluido en tasas o no, está prohibido y constituye un delito.

En este enlace encontrará más información sobre cómo solicitar una autorización por escrito en forma de licencia: <https://ibo.org/become-an-ib-school/ib-publishing/licensing/applying-for-a-license/>.

Instructions to Examiners

Abbreviations

- M** Marks awarded for attempting to use a correct **Method**.
- A** Marks awarded for an **Answer** or for **Accuracy**; often dependent on preceding **M** marks.
- R** Marks awarded for clear **Reasoning**.
- AG** Answer given in the question and so no marks are awarded.
- FT** Follow through. The practice of awarding marks, despite candidate errors in previous parts, for their correct methods/answers using incorrect results.

Using the markscheme

1 General

Award marks using the annotations as noted in the markscheme eg **M1**, **A2**.

2 Method and Answer/Accuracy marks

- Do **not** automatically award full marks for a correct answer; all working **must** be checked, and marks awarded according to the markscheme.
- It is generally not possible to award **M0** followed by **A1**, as **A** mark(s) depend on the preceding **M** mark(s), if any.
- Where **M** and **A** marks are noted on the same line, e.g. **M1A1**, this usually means **M1** for an **attempt** to use an appropriate method (e.g. substitution into a formula) and **A1** for using the **correct** values.
- Where there are two or more **A** marks on the same line, they may be awarded independently; so if the first value is incorrect, but the next two are correct, award **A0A1A1**.
- Where the markscheme specifies **A3**, **M2** etc., do **not** split the marks, unless there is a note.
- The response to a “show that” question does not need to restate the **AG** line, unless a **Note** makes this explicit in the markscheme.
- Once a correct answer to a question or part question is seen, ignore further working even if this working is incorrect and/or suggests a misunderstanding of the question. This will encourage a uniform approach to marking, with less examiner discretion. Although some candidates may be advantaged for that specific question item, it is likely that these candidates will lose marks elsewhere too.
- An exception to the previous rule is when an incorrect answer from further working is used **in a subsequent part**. For example, when a correct exact value is followed by an incorrect decimal approximation in the first part and this approximation is then used in the second part. In this situation, award **FT** marks as appropriate but do not award the final **A1** in the first part. Examples:

	Correct answer seen	Further working seen	Any FT issues?	Action
1.	$8\sqrt{2}$	5.65685... (incorrect decimal value)	No. Last part in question.	Award A1 for the final mark (condone the incorrect further working)
2.	$\frac{35}{72}$	0.468111... (incorrect decimal value)	Yes. Value is used in subsequent parts.	Award A0 for the final mark (and full FT is available in subsequent parts)

3 Implied marks

Implied marks appear in **brackets e.g. (M1)**, and can only be awarded if **correct** work is seen or implied by subsequent working/answer.

4 Follow through marks (only applied after an error is made)

Follow through (**FT**) marks are awarded where an incorrect answer from one **part** of a question is used correctly in **subsequent** part(s) (e.g. incorrect value from part (a) used in part (d) or incorrect value from part (c)(i) used in part (c)(ii)). Usually, to award **FT** marks, **there must be working present** and not just a final answer based on an incorrect answer to a previous part. However, if all the marks awarded in a subsequent part are for the answer or are implied, then **FT** marks should be awarded for *their* correct answer, even when working is not present.

For example: following an incorrect answer to part (a) that is used in subsequent parts, where the markscheme for the subsequent part is **(M1)A1**, it is possible to award full marks for *their* correct answer, **without working being seen**. For longer questions where all but the answer marks are implied this rule applies but may be overwritten by a **Note** in the Markscheme.

- Within a question part, once an **error** is made, no further **A** marks can be awarded for work which uses the error, but **M** marks may be awarded if appropriate.
- If the question becomes much simpler because of an error then use discretion to award fewer **FT** marks, by reflecting on what each mark is for and how that maps to the simplified version.
- If the error leads to an inappropriate value (e.g. probability greater than 1, $\sin \theta = 1.5$, non-integer value where integer required), do not award the mark(s) for the final answer(s).
- The markscheme may use the word “their” in a description, to indicate that candidates may be using an incorrect value.
- If the candidate’s answer to the initial question clearly contradicts information given in the question, it is not appropriate to award any **FT** marks in the subsequent parts. This includes when candidates fail to complete a “show that” question correctly, and then in subsequent parts use their incorrect answer rather than the given value.
- Exceptions to these **FT** rules will be explicitly noted on the markscheme.
- If a candidate makes an error in one part but gets the correct answer(s) to subsequent part(s), award marks as appropriate, unless the command term was “Hence”.

5 Mis-read

If a candidate incorrectly copies values or information from the question, this is a mis-read (**MR**). A candidate should be penalized only once for a particular misread. Use the **MR** stamp to indicate that this has been a misread and do not award the first mark, even if this is an **M** mark, but award all others as appropriate.

- If the question becomes much simpler because of the **MR**, then use discretion to award fewer marks.
- If the **MR** leads to an inappropriate value (e.g. probability greater than 1, $\sin \theta = 1.5$, non-integer value where integer required), do not award the mark(s) for the final answer(s).
- Miscopying of candidates' own work does **not** constitute a misread, it is an error.
- If a candidate uses a correct answer, to a "show that" question, to a higher degree of accuracy than given in the question, this is NOT a misread and full marks may be scored in the subsequent part.
- **MR** can only be applied when work is seen. For calculator questions with no working and incorrect answers, examiners should **not** infer that values were read incorrectly.

6 Alternative methods

Candidates will sometimes use methods other than those in the markscheme. Unless the question specifies a method, other correct methods should be marked in line with the markscheme. If the command term is 'Hence' and not 'Hence or otherwise' then alternative methods are not permitted unless covered by a note in the mark scheme.

- Alternative methods for complete questions are indicated by **METHOD 1**, **METHOD 2**, etc.
- Alternative solutions for parts of questions are indicated by **EITHER . . . OR**.

7 Alternative forms

Unless the question specifies otherwise, **accept** equivalent forms.

- As this is an international examination, accept all alternative forms of **notation** for example 1.9 and 1,9 or 1000 and 1,000 and 1.000.
- Do not accept final answers written using calculator notation. However, **M** marks and intermediate **A** marks can be scored, when presented using calculator notation, provided the evidence clearly reflects the demand of the mark.
- In the markscheme, equivalent **numerical** and **algebraic** forms will generally be written in brackets immediately following the answer.
- In the markscheme, some **equivalent** answers will generally appear in brackets. Not all equivalent notations/answers/methods will be presented in the markscheme and examiners are asked to apply appropriate discretion to judge if the candidate work is equivalent.

8 Format and accuracy of answers

If the level of accuracy is specified in the question, a mark will be linked to giving the answer to the required accuracy. If the level of accuracy is not stated in the question, the general rule applies to final answers: *unless otherwise stated in the question all numerical answers must be given exactly or correct to three significant figures.*

Where values are used in subsequent parts, the markscheme will generally use the exact value, however candidates may also use the correct answer to 3 sf in subsequent parts. The markscheme will often explicitly include the subsequent values that come “*from the use of 3 sf values*”.

Simplification of final answers: Candidates are advised to give final answers using good mathematical form. In general, for an **A** mark to be awarded, arithmetic should be completed, and

any values that lead to integers should be simplified; for example, $\sqrt{\frac{25}{4}}$ should be written as $\frac{5}{2}$.

An exception to this is simplifying fractions, where lowest form is not required (although the numerator and the denominator must be integers); for example, $\frac{10}{4}$ may be left in this form or

written as $\frac{5}{2}$. However, $\frac{10}{5}$ should be written as 2, as it simplifies to an integer.

Algebraic expressions should be simplified by completing any operations such as addition and multiplication, e.g. $4e^{2x} \times e^{3x}$ should be simplified to $4e^{5x}$, and $4e^{2x} \times e^{3x} - e^{4x} \times e^x$ should be simplified to $3e^{5x}$. Unless specified in the question, expressions do not need to be factorized, nor do factorized expressions need to be expanded, so $x(x+1)$ and $x^2 + x$ are both acceptable.

Please note: intermediate **A** marks do NOT need to be simplified.

9 Calculators

A GDC is required for this paper, but If you see work that suggests a candidate has used any calculator not approved for IB DP examinations (eg CAS enabled devices), please follow the procedures for malpractice.

10. Presentation of candidate work

Crossed out work: If a candidate has drawn a line through work on their examination script, or in some other way crossed out their work, do not award any marks for that work unless an explicit note from the candidate indicates that they would like the work to be marked.

More than one solution: Where a candidate offers two or more different answers to the same question, an examiner should only mark the first response unless the candidate indicates otherwise. If the layout of the responses makes it difficult to judge, examiners should apply appropriate discretion to judge which is “first”.

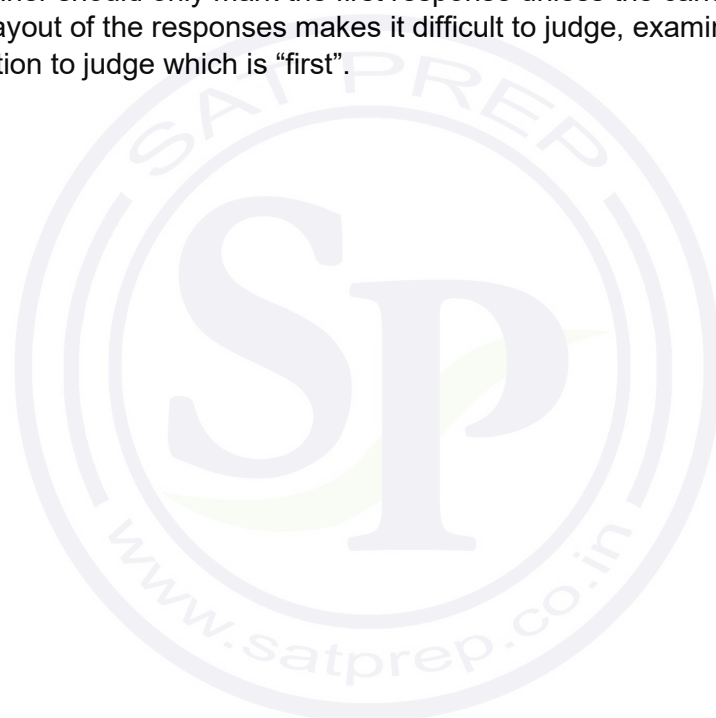

1. $X \sim \text{Po}(8.8)$ (M1)

Note: Award (M1) for calculating the mean, 8.8, of the distribution

$P(X > 9) = P(X \geq 10)$ OR $P(X > 9) = 1 - P(X \leq 9)$ (M1)

$P(X > 9) = 0.386$ (0.386260...) (M1)A1

Note: Award (M1)(M0)(M1)A0 for finding $P(X \geq 9) = 0.518$ (0.517719...)
OR $P(X \leq 9) = 0.614$ (0.613740...).

Total [4 marks]

2. (a) every point in the shaded region is closer to tower T4 R1

Note: Specific reference must be made to the closeness of tower T4.

[1 mark]

(b) $(-9, 1)$ A1A1

Note: Award A1 for each correct coordinate. Accept $x = -9$ and $y = 1$.
Award at most A0A1 if parentheses are missing.

[2 marks]

(c) correct use of gradient formula (M1)

e.g. $(m =) \frac{5-3}{-9--13} \left(= \frac{1}{2} \right)$

taking negative reciprocal of **their** m (at any point) (M1)

edge gradient = -2 A1

[3 marks]

Total [6 marks]

3. (a) (i) attempt to find u_{20} using an arithmetic sequence **(M1)**
 e.g. $u_1 = 500$ and $d = 100$ **OR** $u_{20} = 500 + 1900$ **OR** 500, 600, 700, ...
 (Charlie ran) 2400 m **A1**
- (ii) ($r =$) 1.02 **(A1)**
 attempt to find u_{20} using a geometric sequence **(M1)**
 e.g. identifying $u_1 = 500$ and a value for r **OR** $500 \times r^{19}$ **OR** 500, 510, 520.2, ...
 (Daniella ran) 728 m (728.405...) **A1**
[5 marks]
- (b) $500 \times 1.02^{n-1} > 500 + (n-1) \times 100$ **(M1)**
 attempt to solve inequality **(M1)**
 $n > 184.215...$
 $n = 185$ **A1**
[3 marks]
Total [8 marks]



4. (a) $50 = 100e^{-1 \times p}$ OR $0.5 = e^{-1 \times p}$ (M1)

OR

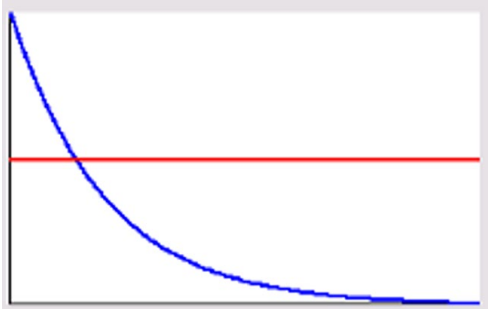

(M1)

0.693 (0.693147..., $\ln 2$)

A1

[2 marks]

(b) $R(1.5) = 100e^{-0.693147... \times 1.5}$ (M1)

35.4(%) (35.3553...)

A1

[2 marks]

(c) $R(t) > 0$ OR $R(t)$ has a horizontal asymptote R1

[1 mark]

(d) Award A1 for **one** reasonable limitation of the domain: A1

small values of t produce unrealistic results

$R(0) = 100\%$

large values of t are not possible

people do not live forever

model is not valid at small or large values of t

The reason should focus on the domain $t \geq 0$. Do not accept answers such as:

recollection varies for different people

memories are discrete not continuous

the nature of the information will change how easily it is recalled

emotional/physical stress can affect recollection/concentration

Note: Do not accept $t \geq 0$ as this is a limitation that has been given in the question.

[1 mark]

Total [6 marks]

5. (a) (i) $\vec{CA} = \begin{pmatrix} -3 \\ -4 \\ -1 \end{pmatrix}$ **A1**

(ii) $\vec{CB} = \begin{pmatrix} 3 \\ -4 \\ -1 \end{pmatrix}$ **A1**

[2 marks]

(b) $\vec{CA} \times \vec{CB} = \begin{pmatrix} 0 \\ -6 \\ 24 \end{pmatrix}$ **(M1)A1**

Note: Do not award **(M1)** if less than 2 entries are correct.

[2 marks]

(c) area is $\frac{1}{2}\sqrt{6^2 + 24^2} = 12.4 \text{ m}^2$ (12.3693..., $3\sqrt{17}$) **(M1)A1**

[2 marks]

Total [6 marks]

6. attempt to find any relevant maximum value **(M1)**
 largest sides are 56.5 and 82.5 **(A1)**
 smallest possible angle is 102.5 **(A1)**

attempt to substitute into area of a triangle formula **(M1)**

$$\frac{1}{2} \times 56.5 \times 82.5 \times \sin(102.5^\circ)$$

= 2280 m² (2275.37...) **A1**

Total [5 marks]

7. (a) (i) $A = \frac{1}{2} \times 6 \times q + \frac{1}{2} \times 8 \times p + 48$ **OR** $A = \frac{1}{2}(p+6)(q+8)$ **OR**
 $A = 3q + 4p + 48$ **A1**
- (ii) valid attempt to link p and q , using tangents, similar triangles or other method **(M1)**
 eg. $\tan \theta = \frac{8}{p}$ and $\tan \theta = \frac{q}{6}$ **OR** $\tan \theta = \frac{p}{8}$ and $\tan \theta = \frac{6}{q}$ **OR** $\frac{8}{p} = \frac{q}{6}$
- correct equation linking p and q **A1**
 eg. $pq = 48$ **OR** $p = \frac{48}{q}$ **OR** $q = \frac{48}{p}$
- substitute $p = \frac{48}{q}$ into a correct area expression **M1**
 eg. $(A =) \frac{1}{2} \times 6 \times q + \frac{1}{2} \times 8 \times \frac{48}{q} + 48$ **OR** $(A =) \frac{1}{2} \left(\frac{48}{q} + 6 \right) (q + 8)$
- $A = 3q + \frac{192}{q} + 48$ **AG**

Note: The **AG** line must be seen with no incorrect, intermediate working, for the final **M1** to be awarded.

[4 marks]

(b) $\frac{-192}{q^2} + 3$ **A1A1**

Note: Award **A1** for $\frac{-192}{q^2}$, **A1** for 3. Award **A1A0** if extra terms are seen.

[2 marks]

(c) (i) $\frac{-192}{q^2} + 3 = 0$ **A1**

(ii) $q = 8$ cm **A1**

[2 marks]

Total [8 marks]

8. (a)

t	1	2	3	4	5	6
$P(T=t)$	$\frac{1}{36}$ (0.027777...)	$\frac{3}{36}$ (0.083333...)	$\frac{5}{36}$ (0.138888...)	$\frac{7}{36}$ (0.194444...)	$\frac{9}{36}$ (0.25)	$\frac{11}{36}$ (0.305555...)

A2

Note: Award **A1** if three to five probabilities are correct.

[2 marks]

(b) (i) $\frac{32}{36} \left(\frac{8}{9}, 0.888888..., 88.9\% \right)$

(A1)

(ii) use of conditional probability
e.g. denominator of 32 **OR** denominator of 0.888888..., etc.

(M1)

$\frac{11}{32} (0.34375, 34.4\%)$

A1

[3 marks]

(c) $\frac{1 \times 1 + 3 \times 2 + 5 \times 3 + \dots + 11 \times 6}{36}$

(M1)

$= \frac{161}{36} \left(4\frac{17}{36}, 4.47, 4.47222... \right)$

A1

[2 marks]

Total [7 marks]

9. (a) (i) $i^2 = -1$ (M1)
 $w = -2 + 1 = -1$ A1
- (ii) $w = -1 + i + 1 = i$ A1
 [3 marks]

- (b) EITHER
 rotation of 90° (anticlockwise, centre at the origin)

A1A1

Note: Award A1 for "rotation" and A1 for " 90° ".

followed by a translation of $\begin{pmatrix} 1 \\ 0 \end{pmatrix}$

A1

OR

translation of $\begin{pmatrix} 0 \\ -1 \end{pmatrix}$

A1

followed by rotation of 90° (anticlockwise, centre at the origin)

A1A1

Note: Award A1 for "rotation" and A1 for " 90° ".

[3 marks]

- (c) EITHER
 move 1 to left to $1 - i$
 then rotate by -90° to
 $-1 - i$

(M1)

A1

OR

$$iz + 1 = 2 - i$$

$$iz = 1 - i$$

$$z = \frac{1 - i}{i}$$

$$-1 - i$$

(M1)

A1

[2 marks]

Total [8 marks]

10. (a) (i) use of Prim's algorithm **M1**
 BC 46 **A1**
 BD 58 **A1**
 DE 23
 EF 47
 Total 174 **A1**

Note: Award **M0A0A0A1** for 174 without correct working e.g. use of Kruskal's, or with no working.
 Award **M1A0A0A1** for 174 by using Prim's from an incorrect starting point.

- (ii) $AB + AC = 55 + 63 = 118$ **(M1)**
 $174 + 118 = 292$ minutes **A1**

- (b) delete a different vertex **A1**
[6 marks]
[1 mark]

Total [7 marks]

11. (a) Convenience **A1**
[1 mark]

- (b) H_0 : 1% of the toys produced are faulty **A1**
 H_1 : More than 1% are faulty **A1**
[2 marks]

- (c) $X \sim B(200, 0.01)$ **(M1)**
 $P(X \geq 4) = 0.142$ **A1**

Note: Any attempt using Normal approximation to find p -value is awarded **M0A0**.

[2 marks]

- (d) $14\% > 10\%$ **R1**
 so there is insufficient evidence to reject H_0 . **A1**

Note: Do not award **R0A1**. Accept "fail to reject H_0 " or "accept H_0 ".

[2 marks]

Total [7 marks]

12. (a) $\frac{dV}{dt} = -kV^{\frac{1}{2}}$ **(M1)**
 use of separation of variables **A1**
 $\Rightarrow \int V^{-\frac{1}{2}} dV = \int -k dt$ **A1**
 $2V^{\frac{1}{2}} = -kt (+c)$ **A1**
 considering initial conditions $40 = c$ **A1**
 $2\sqrt{324} = -10k + 40$
 $\Rightarrow k = 0.4$ **A1**
 $2\sqrt{V} = -0.4t + 40$
 $\Rightarrow \sqrt{V} = 20 - 0.2t$ **A1**

Note: Award **A1** for any correct intermediate step that leads to the **AG**.

$$\Rightarrow V = \left(20 - \frac{t}{5}\right)^2$$
AG

Note: Do not award the final **A1** if the **AG** line is not stated.

[6 marks]

- (b) $0 = \left(20 - \frac{t}{5}\right)^2 \Rightarrow t = 100$ minutes **(M1)A1**

[2 marks]

Total [8 marks]

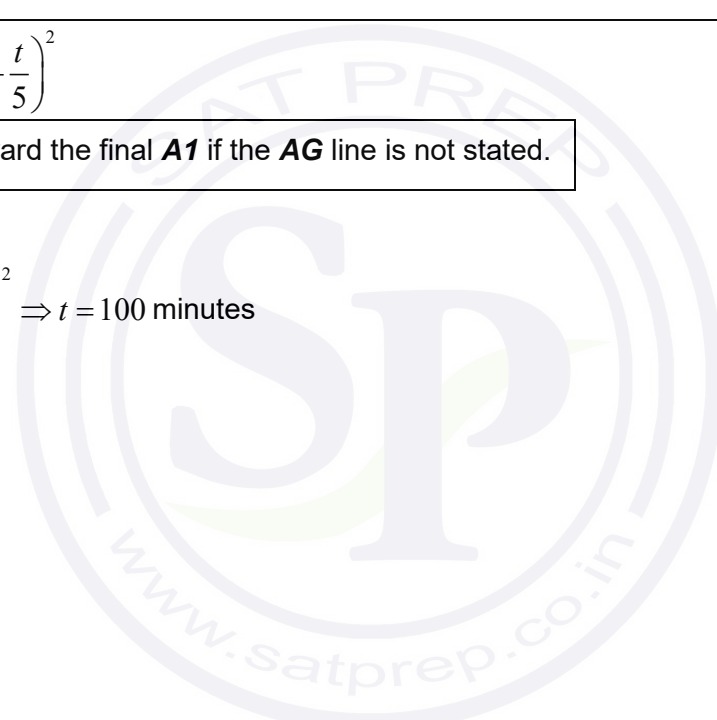

13. (a) $r = \begin{pmatrix} 0.8 \\ 1.3 \\ -0.3 \end{pmatrix} + \lambda \begin{pmatrix} -2 \\ -3 \\ 1 \end{pmatrix}$ **A1A1**

Note: Award **A1** for each correct vector. Award **A0A1** if their “ $r =$ ” is omitted.

[2 marks]

(b) (i) $-0.3 + \lambda = 0$ **(M1)**
 $\Rightarrow \lambda = 0.3$

$r = \begin{pmatrix} 0.8 \\ 1.3 \\ -0.3 \end{pmatrix} + 0.3 \begin{pmatrix} -2 \\ -3 \\ 1 \end{pmatrix} = \begin{pmatrix} 0.2 \\ 0.4 \\ 0 \end{pmatrix}$ **(M1)**

P has coordinates (0.2, 0.4, 0) **A1**

Note: Accept the coordinates of P in vector form.

(ii) $\sqrt{0.2^2 + 0.4^2}$ **(M1)**
 $= 0.447 \text{ km } (=447 \text{ m})$ **A1**

[5 marks]

Total [7 marks]

14. (a) $158 \times 6 = 948 \text{ (g)}$ **(M1)A1**

[2 marks]

(b) variance 6×13^2 **(M1)**
 SD = 31.8(g) ($13\sqrt{6}$, 31.8433...)

A1

[2 marks]

(c) $X \sim N(948, 31.8433...^2)$
 $P(X > 1000) = 0.0512$ (0.0512350...) **(M1)A1**

Note: Accept 0.0510 (0.0510014...) if 3 sf value 31.8 is used.

Award **(M1)A1FT** if the answer is correct for their SD, even if no working is shown. e.g. If the SD is 78 then accept 0.252.

[2 marks]

Total [6 marks]

15. (a) $\sin(x+y) = 0$
 $\Rightarrow x+y = 0$
 (the equation of L_1 is) $y = -x$

A1
(M1)
A1

[3 marks]

- (b) $x+y = \pi$ **OR** $y = -x + \pi$

(M1)A1

[2 marks]

Total [5 marks]

16. (a) $M = \begin{pmatrix} 0 & 1 & 1 & 1 & 0 & 0 \\ 1 & 0 & 1 & 0 & 1 & 0 \\ 1 & 1 & 0 & 0 & 0 & 1 \\ 1 & 0 & 0 & 0 & 1 & 1 \\ 0 & 1 & 0 & 1 & 0 & 1 \\ 0 & 0 & 1 & 1 & 1 & 0 \end{pmatrix}$

A1A1A1

Note: Award **A1** for each two correct rows.

[3 marks]

- (b) calculating M^6
 143

(M1)
A1

[2 marks]

Total [6 marks]

17. new function is $f(x-a)+b (= \ln(x-a)+b)$

(M1)

$$f(0) = \ln(-a) + b = 1$$

A1

$$f(e^3) = \ln(e^3 - a) + b = 1 + \ln 2$$

A1

$$\ln(-a) = \ln(e^3 - a) - \ln 2$$

(M1)

$$\ln(-a) = \ln\left(\frac{e^3 - a}{2}\right)$$

$$-a = \frac{e^3 - a}{2}$$

$$-2a = e^3 - a$$

$$a = -e^3 \quad (= -20.0855\dots)$$

A1

$$b = 1 - \ln e^3 = 1 - 3 = -2$$

(M1)A1

Total [7 marks]



Markscheme

Specimen paper

Mathematics: applications and interpretation

Higher level

Paper 1

Instructions to Examiners

Abbreviations

- M** Marks awarded for attempting to use a correct **Method**.
- A** Marks awarded for an **Answer** or for **Accuracy**; often dependent on preceding **M** marks.
- R** Marks awarded for clear **Reasoning**.
- AG** Answer given in the question and so no marks are awarded.

Using the markscheme

1 General

*Award marks using the annotations as noted in the markscheme eg **M1**, **A2**.*

2 Method and Answer/Accuracy marks

- Do **not** automatically award full marks for a correct answer; all working **must** be checked, and marks awarded according to the markscheme.
- It is generally not possible to award **M0** followed by **A1**, as **A** mark(s) depend on the preceding **M** mark(s), if any.
- Where **M** and **A** marks are noted on the same line, e.g. **M1A1**, this usually means **M1** for an **attempt** to use an appropriate method (e.g. substitution into a formula) and **A1** for using the **correct** values.
- Where there are two or more **A** marks on the same line, they may be awarded independently; so if the first value is incorrect, but the next two are correct, award **A0A1A1**.
- Where the markscheme specifies **M2**, **A3**, etc., do **not** split the marks, unless there is a note.
- Once a correct answer to a question or part-question is seen, ignore further correct working. However, if further working indicates a lack of mathematical understanding do not award the final **A1**. An exception to this may be in numerical answers, where a correct exact value is followed by an incorrect decimal. However, if the incorrect decimal is carried through to a subsequent part, and correct **FT** working shown, award **FT** marks as appropriate but do not award the final **A1** in that part.

Examples

	Correct answer seen	Further working seen	Action
1.	$8\sqrt{2}$	5.65685... <i>(incorrect decimal value)</i>	Award the final A1 <i>(ignore the further working)</i>
2.	$\frac{1}{4}\sin 4x$	$\sin x$	Do not award the final A1
3.	$\log a - \log b$	$\log(a - b)$	Do not award the final A1

3 Implied marks

*Implied marks appear in **brackets e.g. (M1)**, and can only be awarded if **correct** work is seen or if implied in subsequent working.*

- Normally the correct work is seen or implied in the next line.
- Marks **without** brackets can only be awarded for work that is **seen**.

4 Follow through marks (only applied after an error is made)

*Follow through (**FT**) marks are awarded where an incorrect answer from one **part** of a question is used correctly in **subsequent** part(s) or subpart(s). Usually, to award **FT** marks, **there must be working present** and not just a final answer based on an incorrect answer to a previous part. However, if the only marks awarded in a subpart are for the answer (i.e. there is no working expected), then **FT** marks should be awarded if appropriate.*

- Within a question part, once an **error** is made, no further **A** marks can be awarded for work which uses the error, but **M** marks may be awarded if appropriate.
- If the question becomes much simpler because of an error then use discretion to award fewer **FT** marks.
- If the error leads to an inappropriate value (e.g. probability greater than 1, use of $r > 1$ for the sum of an infinite GP, $\sin \theta = 1.5$, non integer value where integer required), do not award the mark(s) for the final answer(s).
- The markscheme may use the word “their” in a description, to indicate that candidates may be using an incorrect value.
- Exceptions to this rule will be explicitly noted on the markscheme.
- If a candidate makes an error in one part, but gets the correct answer(s) to subsequent part(s), award marks as appropriate, unless the question says hence. It is often possible to use a different approach in subsequent parts that does not depend on the answer to previous parts.

5 Mis-read

*If a candidate incorrectly copies information from the question, this is a mis-read (**MR**). Apply a **MR** penalty of 1 mark to that question*

- If the question becomes much simpler because of the **MR**, then use discretion to award fewer marks.
- If the **MR** leads to an inappropriate value (e.g. probability greater than 1, $\sin \theta = 1.5$, non-integer value where integer required), do not award the mark(s) for the final answer(s).
- Mis-copying of candidates’ own work does **not** constitute a misread, it is an error.
- The **MR** penalty can only be applied when work is seen. For calculator questions with no working and incorrect answers, examiners should **not** infer that values were read incorrectly.

6 Alternative methods

Candidates will sometimes use methods other than those in the markscheme. Unless the question specifies a method, other correct methods should be marked in line with the markscheme

- Alternative methods for complete questions are indicated by **METHOD 1**, **METHOD 2**, etc.
- Alternative solutions for part-questions are indicated by **EITHER . . . OR**.

7 Alternative forms

*Unless the question specifies otherwise, **accept** equivalent forms.*

- As this is an international examination, accept all alternative forms of **notation**.
- In the markscheme, equivalent **numerical** and **algebraic** forms will generally be written in brackets immediately following the answer.
- In the markscheme, **simplified** answers, (which candidates often do not write in examinations), will generally appear in brackets. Marks should be awarded for either the form preceding the bracket or the form in brackets (if it is seen).

8 Accuracy of Answers

If the level of accuracy is specified in the question, a mark will be linked to giving the answer to the required accuracy. There are two types of accuracy errors, and the final answer mark should not be awarded if these errors occur.

- **Rounding errors**: only applies to final answers not to intermediate steps.
- **Level of accuracy**: when this is not specified in the question the general rule applies to final answers: *unless otherwise stated in the question all numerical answers must be given exactly or correct to three significant figures.*

9 Calculators

A GDC is required for this examination, but calculators with symbolic manipulation features/ CAS functionality are not allowed.

Calculator notation

The subject guide says:

Students must always use correct mathematical notation, not calculator notation.

Do **not** accept final answers written using calculator notation. However, do not penalize the use of calculator notation in the working.

1. (a) discrete

A1
[1 mark]

(b) $\frac{24 + 60 + 3k + 40 + 15 + 6}{88 + k} = 2$

M1A1

Note: Award **M1** for substitution into the formula for the mean, award **A1** for a correct equation.

attempt to solve their equation

(M1)

$k = 31$

A1
[4 marks]

(c) systematic

A1
[1 mark]

Total [6 marks]

2. (a) 20

A1
[1 mark]

(b)

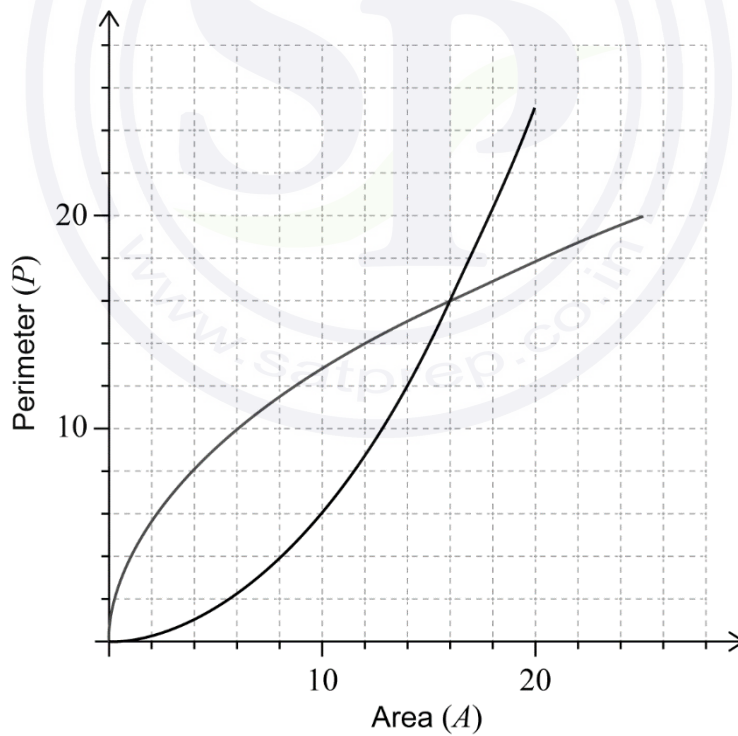

(M1)A1A1

Note: Award **(M1)** for reflection in the line $P = A$, award **A1** for endpoint at $(20, 25)$, award **A1** for passing through $(16, 16)$.

[3 marks]

(c) when the perimeter is 8, the area is 4

A1
[1 mark]

Total [5 marks]

3. (a) (i) 1750 A1
 (ii) $1350 + 400(1.25)^{-5}$ (M1)
 $= 1480$ A1

Note: Accept 1481.

[3 marks]

- (b) $1400 = 1350 + 400(1.25)^{-t}$ (M1)
 9.32 (days (9.31885...)) (days) A1
[2 marks]

- (c) 1350 A1

Note: Accept 1351 as a valid interpretation of the model as $P=1350$ is an asymptote.

[1 mark]

Total [6 marks]

4. (a) $\frac{3-1}{7-3}$ (M1)
 $= 0.5$ A1
[2 marks]
 (b) $y-2 = -2(x-5)$ (A1)(M1)

Note: Award (A1) for their -2 seen, award (M1) for the correct substitution of (5, 2) and their normal gradient in equation of a line.

$2x + y - 12 = 0$ A1
[3 marks]

- (c) every point in the cell is closer to E than any other snow shelter A1
[1 mark]

Total [6 marks]

5. (a) $\frac{50 \times \pi}{180} = 0.873$ (0.872664...) A1
[1 mark]

(b) volume = $240 \left(\pi \times 8.4^2 - \frac{1}{2} \times 8.4^2 \times 0.872664... \right)$ M1M1M1

Note: Award **M1** $240 \times$ area, award **M1** for correctly substituting area sector formula, award **M1** for subtraction of the angles or their areas.

= 45800 (= 45811.96071) A1
[4 marks]

Total [5 marks]

6. (a) $\frac{4}{18} \left(\frac{2}{9} \right)$ A1
[1 mark]

(b) $-3 \times \frac{1}{18} + (-1) \times \frac{4}{18} + 0 \times \frac{3}{18} + \dots + 5 \times \frac{7}{18}$ (M1)

Note: Award **(M1)** for their correct substitution into the formula for expected value.

= $1.83 \left(\frac{33}{18}, 1.83333... \right)$ A1
[2 marks]

(c) $2 \times \frac{1}{18} \times \frac{3}{18}$ (M1)(M1)

Note: Award **(M1)** for $\frac{1}{18} \times \frac{3}{18}$, award **(M1)** for multiplying their product by 2.

= $\frac{1}{54} \left(\frac{6}{324}, 0.0185185..., 1.85\% \right)$ A1
[3 marks]

Total [6 marks]

7. (a) $E = 5(2\sin t)^2 (= 20\sin^2 t)$ **A1**
[1 mark]
- (b) $\frac{dE}{dt} = 40\sin t \cos t$ **(M1)A1**
[2 marks]
- (c) $t = 0.126$ **(M1)A1**
[2 marks]
- Total [5 marks]**

8. (a) $\frac{\sin \hat{CAB}}{6} = \frac{\sin 15^\circ}{4.5}$ **(M1)(A1)**
- $\hat{CAB} = 20.2^\circ (20.187415\dots)$ **A1**
- Note:** Award **(M1)** for substituted sine rule formula and award **(A1)** for correct substitutions.
- [3 marks]**
- (b) $\hat{CBD} = 20.2 + 15 = 35.2^\circ$ **A1**
(let X be the point on BD where Ollie activates the sensor)
- $\tan 35.18741\dots^\circ = \frac{1.8}{BX}$ **(M1)**
- Note:** Award **A1** for their correct angle \hat{CBD} . Award **M1** for correctly substituted trigonometric formula.
- $BX = 2.55285\dots$ **A1**
- $5 - 2.55285\dots$ **(M1)**
- $= 2.45 \text{ (m)} (2.44714\dots)$ **A1**
[5 marks]
- Total [8 marks]**

9. (a) $s_{n-1} = \sqrt{\frac{10}{9}} \times 0.0196 = 0.02066\dots$ **(M1)A1**
[2 marks]

(b) (1.463, 1.493) **(M1)A1**

Note: If s_n used answer is (1.464, 1.492), award **M1A0**.

[2 marks]

(c) 95% of the time these results would be produced by a population with mean of less than 1.5 kg, so it is likely the mean weight is less than 1.5 kg **R1**
[1 mark]

Total [5 marks]

10. let T be the time to serve both customers and T_i the time to serve the i th customer **R1**
 assuming independence of T_1 and T_2
 T is normally distributed and $T = T_1 + T_2$ **(M1)**
 $E(T) = 1.5 + 1.5 = 3$ **A1**
 $\text{Var}(T) = 0.4^2 + 0.4^2 = 0.32$ **M1A1**
 $P(T < 4) = 0.961$ **A1**
Total [6 marks]

11. (a) $15 \times 0 + 2d + 4 = 0$
 $d = -2$

(M1)

A1

[2 marks]

(b) $a \begin{pmatrix} -15 \\ 2 \\ 4 \end{pmatrix} \times \begin{pmatrix} 0 \\ -2 \\ 1 \end{pmatrix}$

(M1)

$= a \begin{pmatrix} 10 \\ 15 \\ 30 \end{pmatrix} \left(= 5a \begin{pmatrix} 2 \\ 3 \\ 6 \end{pmatrix} \right)$

A1

magnitude is $5a\sqrt{2^2 + 3^2 + 6^2} = 14$

M1

$a = \frac{14}{35} (= 0.4)$

A1

[4 marks]

Total [6 marks]

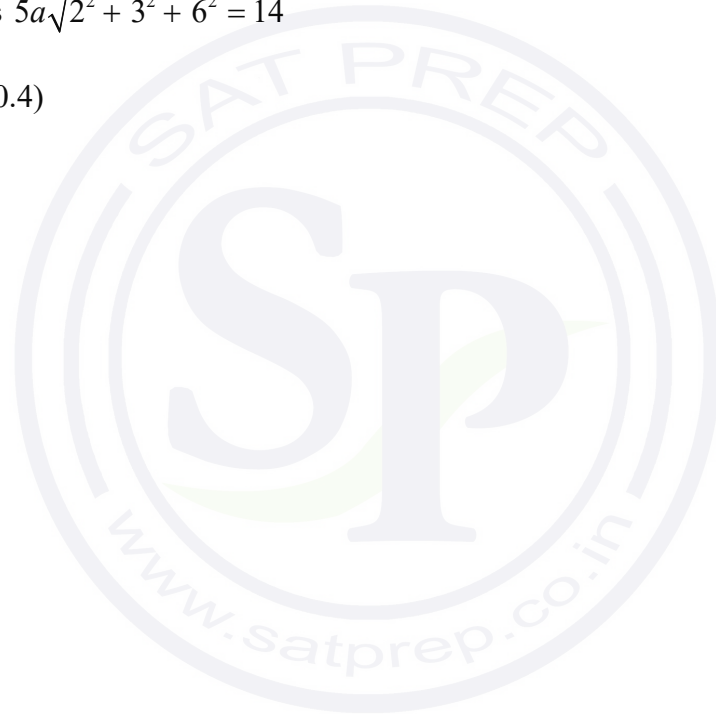

12. (Model A)

$$R = 3pe^{-0.5p}$$

M1

predicted values

p	R
1	1.8196
2	2.2073
3	2.0082

(A1)

$$SS_{res} = (1.8196 - 1.5)^2 + (2.2073 - 1.8)^2 + (2.0082 - 1.5)^2$$

(M1)

$$= 0.5263\dots$$

A1

(Model B)

$$R = 2.5pe^{-0.6p}$$

predicted values

p	R
1	1.372
2	1.506
3	1.2397

(A1)

$$SS_{res} = 0.170576\dots$$

A1

chose model B

A1

Note: Method marks can be awarded if seen for either model A or model B. Award final **A1** if it is a correct deduction from their calculated values for A and B.

Total [7 marks]

13. (a) $\frac{dy}{dx} = \frac{16-20}{24-20}$ **M1**
 $= -1$ **A1**
[2 marks]

(b) asymptote of trajectory along $r = k \begin{pmatrix} 2 \\ 1 \end{pmatrix}$ **M1A1**

Note: Award **M1A0** if asymptote along $\begin{pmatrix} 1 \\ 2 \end{pmatrix}$.

trajectory begins at (8, 10) with negative gradient **A1A1**
[4 marks]

Total [6 marks]

14. (a) (i) $a = 33$ **A1**
(ii) $\frac{1}{\sqrt[3]{0.08}} = 2.32$ **M1A1**
[3 marks]

(b) volume within outer dome **M1A1**
 $\frac{2}{3}\pi \times 16^3 + \pi \times 16^2 \times 17 = 22250.85$
volume within inner dome
 $\pi \int_0^{33} \left(\frac{33-y}{0.08} \right)^2 dy = 3446.92$ **M1A1**
volume between = $22250.85 - 3446.92 = 18803.93 \text{ m}^3$ **A1**
[5 marks]

Total [8 marks]

15. (a) (i) $4e^{\frac{\pi}{4}i}, 8e^{\frac{3\pi}{4}i}, 16e^{\pi i}$ ($= 4i, -4\sqrt{2} + 4\sqrt{2}i, -16$) **(M1)A1**

(ii)

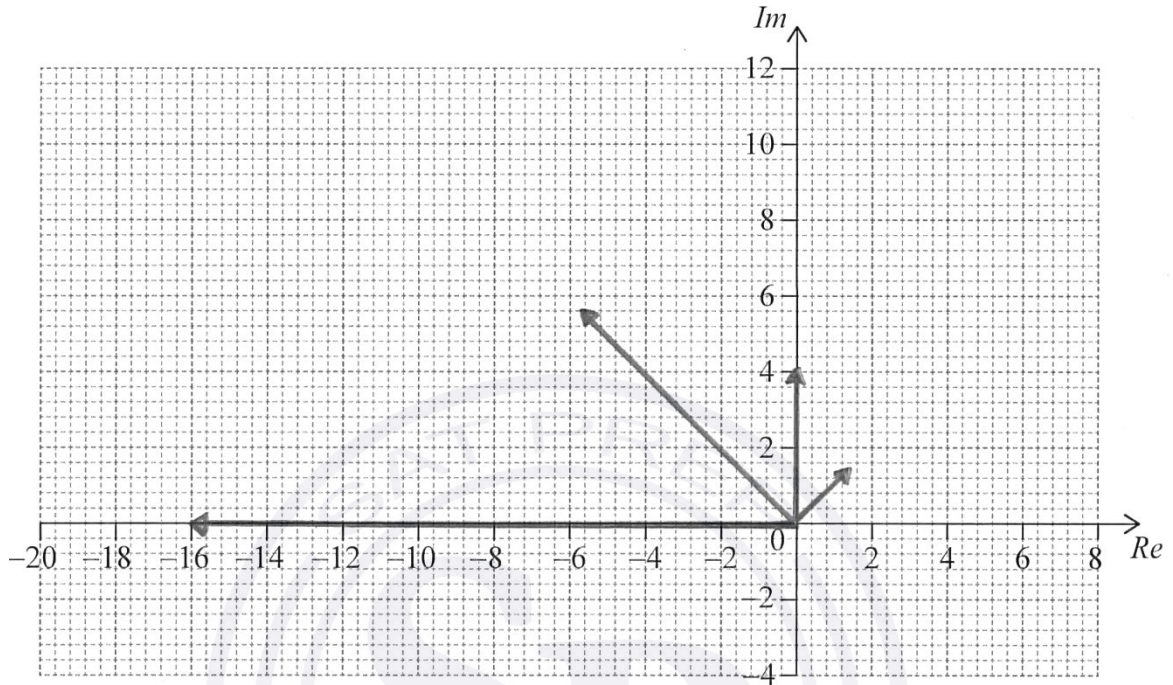

A3

Note: Award **A1** for correct arguments, award **A1** for $4i$ and -16 clearly indicated, award **A1** for $|w| < 4$ and $4 < |w^3| < 16$.

[5 marks]

(b) $2^2 + 1^2 = a^2$

M1

$a = \sqrt{5}$ ($= 2.24$)

A1

[2 marks]

Total [7 marks]

16. (a) $H_0 : m = 3, H_1 : m < 3$ A1

Note: Accept equivalent statements in words.

[1 mark]

(b) (let X be the number of fish caught)
 $P(X \leq 1 | m = 3) = 0.199$

M1A1
 [2 marks]

(c) $P(X \geq 2 | m = 2.5) (= 1 - P(X \leq 1 | m = 2.5))$

M1A1

Note: Award **M1** for using $m = 2.5$ to evaluate a probability,
 award **A1** for also having $X \geq 2$.

= 0.713

A1
 [3 marks]

Total [6 marks]

17. (a) $P(X = 8)$ (M1)

Note: Award **(M1)** for evidence of recognizing binomial probability.

eg, $P(X = 8), X \sim B\left(20, \frac{6}{15}\right)$.

= 0.180 (0.179705...)

A1
 [2 marks]

(b) let x be the number of male students

recognize that probability of selecting a male is equal to $\frac{x}{80}$

(A1)

$\left(\text{set up equation } {}^{20}C_8 \left(\frac{x}{80}\right)^8 \left(\frac{80-x}{80}\right)^{12} = \right) 0.153357$

(M1)

number of male students = 37

(M1)A1

Note: Award **(M1)A0** for 27.

[4 marks]

Total [6 marks]

18. $\log A = x \log B + y \log C + \log k$ **(M1)**

$$\log 5.74 = x \log 2.1 + y \log 3.4 + \log k$$

$$\log 2.88 = x \log 1.5 + y \log 2.4 + \log k$$

$$\log 0.980 = x \log 0.8 + y \log 1.9 + \log k$$
 M1A1

Note: Allow any consistent base, allow numerical equivalents.

attempting to solve their system of equations **(M1)**

$$x = 1.53, y = 0.505$$
 A1

$$k = 0.997$$
 A1

Total [6 marks]

